

- NOTES:**
1. ULTRA SLEEVE CASTING IS ANSI/NSF-61 EPOXY COATED DUCTILE IRON.
 2. GASKETS (NOT SHOWN) ARE ANSI/NSF 61 NBR
 3. HARDWARE (NOT SHOWN) ARE FLUROPOLYMER COATED 18-8 STAINLESS STEEL
 4. REFER TO INDIVIDUAL PRODUCT LABEL FOR PRESSURE RATING AND TORQUE REQUIREMENTS
 5. SECTION A-A SHOWS ENCAPSUALTION DIMENSIONS.
 6. FOR SPECIFIC PROJECT APPLICATIONS, PLEASE CONTACT TPS FOR MORE INFORMATION

3/4" NPT TEST PORT (2 PLACES)

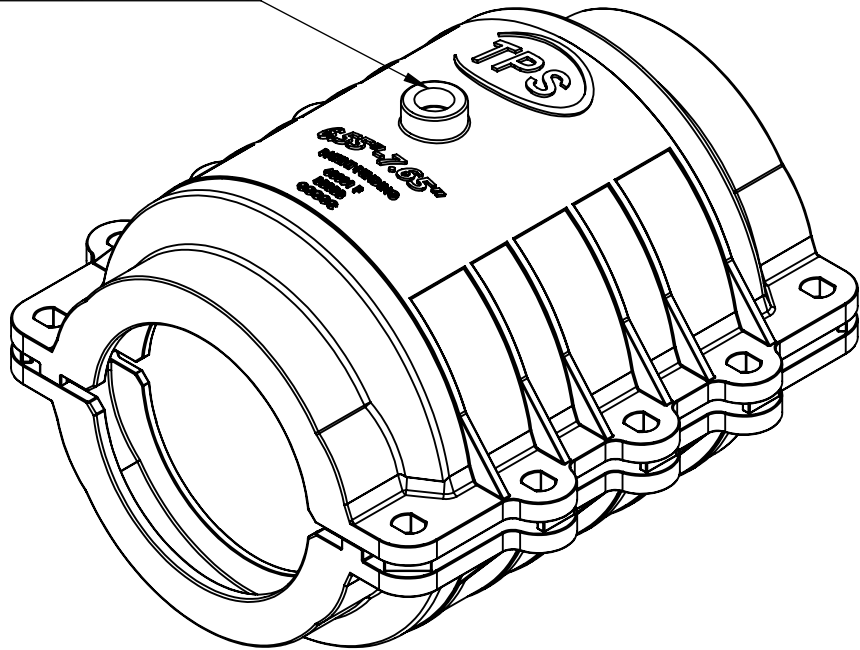

TABLE 1

SIZE	OVERALL RANGE	LOWER RANGE	UPPER RANGE	"A" DIM	"B" DIM	"C" DIM	"D" DIM	"E" DIM
2"	2.35-3.13	2.35-2.78	2.78-3.13	12.7	10.0	17.25	11.0	8.0
4"	4.45-5.61	4.45-5.10	5.12-5.61	15.25	12.5	17.25	11.0	10.0
6"	6.55-7.65	6.55-7.15	7.15-7.65	17.25	15.0	17.25	11.0	12.5
8"	8.54-9.84	8.54-9.22	9.25-9.84	20.5	18.0	18.0	11.25	15.25
10" US	10.64-11.46	10.64-11.15	11.15-11.46	20.9	18.5	19.0	13.4	15.9
10" OS	11.34-12.16	11.34-11.71	11.71-12.16	20.9	18.5	19.0	13.4	15.9
12" US	12.62-13.56	12.62-13.26	13.15-13.56	23.25	20.5	19.0	13.4	18.13
12" OS	13.42-14.45	13.42-13.92	14.00-14.45	23.25	20.5	19.0	13.4	18.13

THE INFORMATION DISCLOSED IN THIS DOCUMENT, INCLUDING ALL DESIGNS AND RELATED MATERIALS, IS THE VALUABLE PROPERTY OF TOTAL PIPING SOLUTION, INC. (TPS). TPS RESERVES ALL PATENT, COPYRIGHT, AND PROPRIETARY RIGHTS TO THE INFORMATION SET FORTH IN THIS DOCUMENT INCLUDING ALL DESIGN, MANUFACTURING, REPRODUCTION, USE AND SALES RIGHTS THERETO, EXCEPT TO THE EXTENT SAID RIGHTS ARE EXPRESSLY GRANTED TO OTHERS. REPRODUCTION, TRANSMISSION, OR DISCLOSURE, WITHOUT TPS'S EXPRESS PRIOR WRITTEN CONSENT, OF THIS DOCUMENT OR THE INFORMATION SET FORTH IN THIS DOCUMENT TO ANY THIRD PARTY IS PROHIBITED.

UNLESS OTHERWISE SPECIFIED DIMENSIONS ARE IN INCHES. TOLERANCES ARE: FRACTIONS: ±1/16" ANGLE: ± 1° DECIMALS: .XX ±.02 .XXX ±.005 DO NOT SCALE DRAWING		CONTRACT NO.		TOTAL PIPING SOLUTIONS INC. P.O. BOX 525, OLEAN, N.Y. 14760			
		APPROVALS	DATE				
THIRD ANGLE PROJECTION		DRAWN: R/JF	030320	ULTRA- Sleeve Submittal Drawing			
		CHECKED:					
		APPD:		SIZE	CAGE CODE	DWG NO	REV
		CUST:		B		50600	C1
				SCALE	1:10	WEIGHT	SHEET 1 OF 1