

- NOTES:**
MATERIAL
 1. SHELL: HEAVY DUTY EPOXY COATED CARBON STEEL (CAST SHELLS ARE DUCTILE IRON MATERIAL)
 2. SEALING GASKET: EPDM
 3. HARDWARE: GRADE 18-8 304 STAINLESS
 4. LIFTING POINTS PROVIDED ON TOP AND BOTTOM SHELLS (CAST SHELLS DO NOT HAVE LIFTING POINTS)
 5. 1-1/4" Deep Well Socket Required for Nuts.

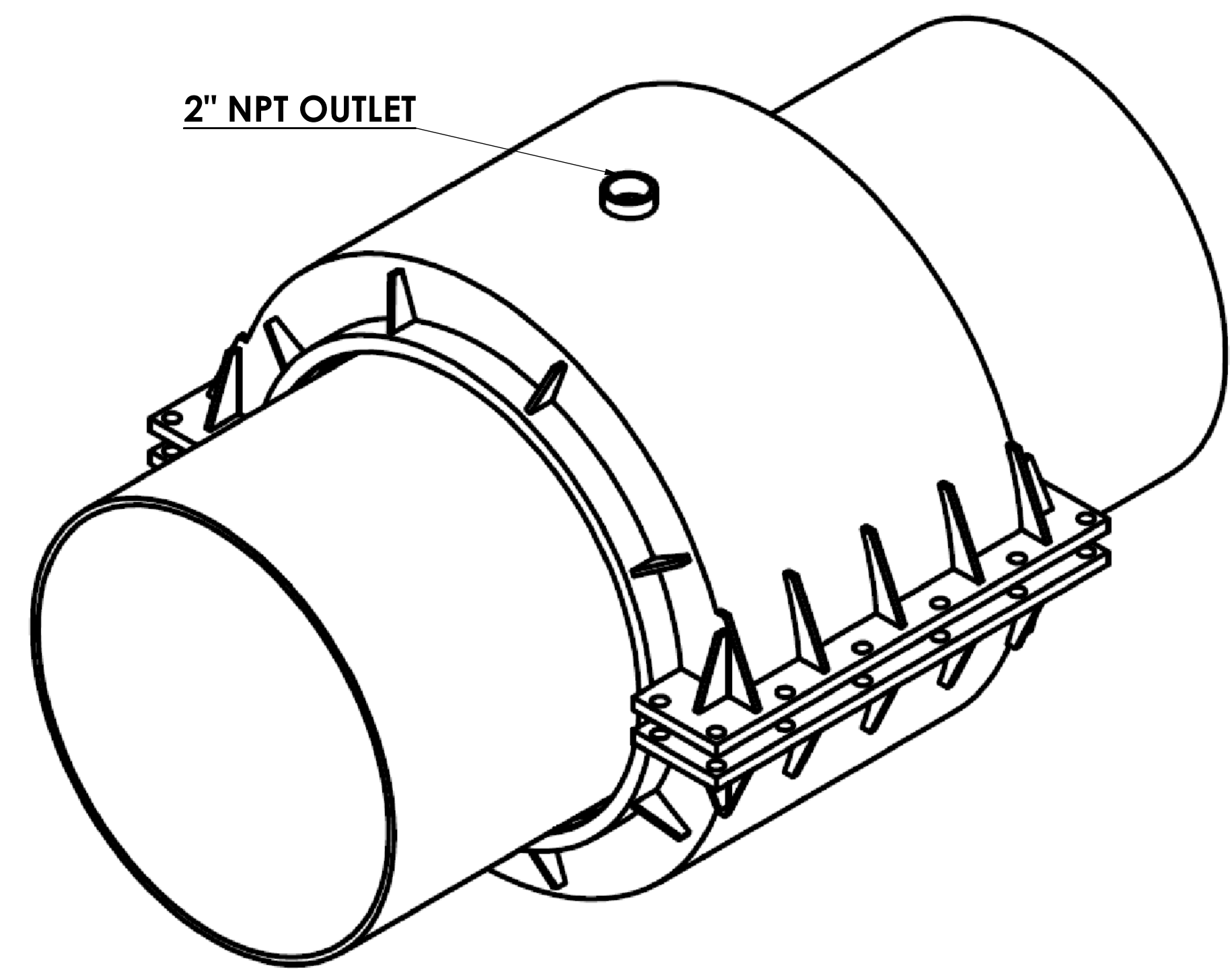

PRODUCT SIZE	PRODUCT RANGE	"OD"	"Y"	"X"	"L"	"W"	"H"
14" DI	15.22"-15.35"	15.30"	21.5"	18"	23.5"	29.5"	25"
16" DI (CAST SHELLS)	17.32"-17.45"	17.40"	24"	16"	21.5"	28.5"	25.25"
16" PIT CAST (CAST SHELLS)	17.72"-17.88"	17.80"	24"	16"	21.5"	28.5"	25.25"
18" DI	19.42"-19.55"	19.50"	27.75"	18"	23.5"	36"	31.25"
24" DI	25.72"-25.85"	25.80"	33.8"	18"	28"	40.5"	37.3"
24" PIT CAST	26.24"-26.40"	26.32"	33.8"	18"	28"	40.5"	37.3"
30" DI	31.94"-32.08"	32.00"	43"	18.5"	23.6"	51"	46"
30" PIT CAST	32.33"-32.47"	32.40"	43"	18.5"	23.6"	51"	46"

THE INFORMATION DISCLOSED IN THIS DOCUMENT, INCLUDING ALL DESIGNS AND RELATED MATERIALS, IS THE VALUABLE PROPERTY OF DRESSER TPS, LLC (DRESSER TPS). DRESSER TPS RESERVES ALL PATENT, COPYRIGHT, AND PROPRIETARY RIGHTS TO THE INFORMATION SET FORTH IN THIS DOCUMENT INCLUDING ALL DESIGN, MANUFACTURING, REPRODUCTION, USE AND SALES RIGHTS THERETO, EXCEPT TO THE EXTENT SAID RIGHTS ARE EXPRESSLY GRANTED TO OTHERS. REPRODUCTION, TRANSMISSION, OR DISCLOSURE, WITHOUT TPS'S EXPRESS PRIOR WRITTEN CONSENT, OF THIS DOCUMENT OR THE INFORMATION SET FORTH IN THIS DOCUMENT TO ANY THIRD PARTY IS PROHIBITED.

UNLESS OTHERWISE SPECIFIED DIMENSIONS ARE IN INCHES.		CONTRACT NO.		DRESSER TPS, LLC P.O. BOX 586, OLEAN, N.Y. 14760	
TOLERANCES ARE:		APPROVALS	DATE	TITLE	
FRACTIONS: ±1/16" ANGLE: ±1°		DRAWN:	1/19/24	LARGE DIAMETER ULTRA SLEEVE SUBMITTAL	
DECIMALS: .XX ±.01 .XXX ±.005		CHECKED:		SIZE	REV
DO NOT SCALE DRAWING		APPD:		D	A
THIRD ANGLE PROJECTION		CUST:		CAGE CODE	DWG NO
		SCALE	1:1	WEIGHT	SHEET 1 OF 1