



Safety Shut-off Valve Series 8600

3850992803

AG

Instruction manual



EN	FR	DE	ES	IT	PT
EU DECLARATION OF CONFORMITY	DECLARATION UE DE CONFORMITE	EU KONFORMITÄTS-ERKLÄRUNG	DECLARACIÓN UE DE CONFORMIDAD	DICHIARAZIONE DI CONFORMITÀ UE	DECLARAÇÃO UE DE CONFORMIDADE

Type Designation

Safety shut off valve

Name and address of the manufacturer	Nom et adresse du fabricant	Name und Anschrift des Herstellers	Nombre y dirección del fabricante	Nome ed indirizzo del fabbricante	Nome e endereço do fabricante
--------------------------------------	-----------------------------	------------------------------------	-----------------------------------	-----------------------------------	-------------------------------

Dresser Utility Solutions GmbH, Hardeckstraße 2, 76185 Karlsruhe, Germany

This declaration of conformity is issued under the sole responsibility of the manufacturer.	La présente déclaration de conformité est établie sous la seule responsabilité du fabricant.	Die alleinige Verantwortung für die Ausstellung dieser Konformitätserklärung trägt der Hersteller.	La presente declaración de conformidad se expide bajo la exclusiva responsabilidad del fabricante.	La presente dichiarazione di conformità è rilasciata sotto la responsabilità esclusiva del fabbricante.	A presente declaração de conformidade é emitida sob a exclusiva responsabilidade do fabricante.
---	--	--	--	---	---

Object of the declaration	Objet de la déclaration	Gegenstand der Erklärung	Objeto de la declaración	Oggetto della dichiarazione	Objecto da declaração
---------------------------	-------------------------	--------------------------	--------------------------	-----------------------------	-----------------------

SSV8511 / 8521 / 8531 with OPSO
SSV8512 / 8522 / 8532 with OPSO and UPSO
SSV8611 / 8621 / 8631 / 8641 with OPSO
SSV8612 / 8622 / 8632 / 8642 with OPSO and UPSO

The object of the declaration described above is in conformity with the relevant Union harmonization legislation and the corresponding harmonized standards	L'objet de la déclaration décrit ci-dessus est conforme à la législation communautaire d'harmonisation applicable ainsi qu'aux normes harmonisées associées	Der oben beschriebene Gegenstand der Erklärung erfüllt die einschlägigen Harmonisierungsrechtsvorschriften der Gemeinschaft und den entsprechenden harmonisierten Normen	El objeto de la declaración descrita anteriormente es conforme a la legislación comunitaria de armonización pertinente y las normas armonizadas correspondientes	L'oggetto della dichiarazione di cui sopra è conforme alla pertinente normativa comunitaria di armonizzazione e alle corrispondenti norme armonizzate	O objecto da declaração acima mencionada está em conformidade com a legislação comunitária aplicável em matéria de harmonização e as correspondentes normas harmonizadas
---	---	--	--	---	--

2014/68/EU (PED) -EN 14382:2019 The used fluids are classified in group 1 according to article 13.		OJ L 189, Page 164, 27.04.2014	category IV		
(EU) 2016/426 (GAR)		OJ L 81, Page 99, 09.03.2016			
2014/30/EU (EMC) -EN 61000-6-2:2019 -EN 61000-6-3:2007/A1:2011/AC:2012		OJ L 96, Page 79, 29.03.2014	only for optional electronic device		
2011/65/EU (RoHS) 2015/863/EU (RoHS) -EN IEC 63000:2018		OJ L 174, Page 88, 01.07.2011 OJ L 137, Page 10, 04.06.2015			

Certificates issued by the notified body	Certificats délivrés par l'organisme notifié	von der notifizierten Stelle ausgestellte Bescheinigungen	Certificados emitidos por el organismo notificado	Certificati rilasciati dall'organismo notificato	Certificados emitidos pelo organismo notificado
--	--	---	---	--	---

PED	Module D	TÜV SÜD Industrie Service GmbH (CE 0036); Westendstr. 199, D-80686 München			
PED	Module B - Type approval	DVGW CERT GmbH (CE 0085) Josef-Wirmer-Str. 1-3 D-53123 Bonn			
PED	Module B - Type approval	DVGW CERT GmbH (CE 0085) Josef-Wirmer-Str. 1-3 D-53123 Bonn			
GAR	Module B - Type approval	DVGW CERT GmbH (CE 0085) Josef-Wirmer-Str. 1-3 D-53123 Bonn			
GAR	Module B - Type approval	DVGW CERT GmbH (CE 0085) Josef-Wirmer-Str. 1-3 D-53123 Bonn			
GAR	Module D	TÜV SÜD Product Service GmbH (CE 0123); Ridlerstr. 65, D-80339 München			

Place and date of issue	Date et lieu d'établissement	Ort und Datum der Ausstellung	Lugar y fecha de expedición	Luogo e data del rilascio	Local e data da emissão
-------------------------	------------------------------	-------------------------------	-----------------------------	---------------------------	-------------------------

Karlsruhe, 26.04.2024

Name, Function, Signature	Nom, Fonction, Signature	Name, Funktion, Unterschrift	Nombre, Cargo, Firma	Nome e cognome, Funzione, Firma	Nome, Cargo, Assinatura
---------------------------	--------------------------	------------------------------	----------------------	---------------------------------	-------------------------

S. Corbière
Quality Manager

© Copyright 2023 Dresser Utility Solutions. All rights reserved.
Document no: **D2036210** AH

To check for an updated version, please visit our website at www.dresserutility.com

HU EU-MEGFELELŐSÉGI NYILATKOZAT	RO DECLARAȚIA UE DE CONFORMITATE	NL EU VERKLARING VAN OVEREENSTEMMING	PL DEKLARACJA ZGODNOŚCI UE	CZ EU PROHLÁŠENÍ O SHODĚ
--	---	---	---	------------------------------------

A gyártó neve és címe	Numele și adresa producătorului	Naam en adres van de fabrikant	Nazwa i adres producenta	Jméno a adresa výrobce
-----------------------	------------------------------------	--------------------------------	--------------------------	------------------------

Ezt a megfelelőségi nyilatkozatot a gyártó kizárólagos felelőssége mellett adják ki.	Această declarație de conformitate este emisă sub responsabilitatea exclusivă a producătorului.	Deze conformiteitsverklaring wordt verstrekt onder de verantwoordelijkheid van de fabrikant.	Ta deklaracja zgodności wydana zostaje na wyłączną odpowiedzialność producenta.	Toto prohlášení o shodě se vydává na výhradní odpovědnost výrobce.
A nyilatkozat tárgya	Obiectul declarației	Onderwerp van de verklaring	Przedmiot deklaracji	Předmět prohlášení

A fent leírt nyilatkozat tárgya összhangban van a vonatkozó uniós harmonizációs jogszabályokkal és a megfelelő harmonizált szabványokkal	Obiectul declarației descrise mai sus este în conformitate cu legislația relevantă de armonizare a Uniunii și cu standardele armonizate corespunzătoare	Het onderwerp van de hierboven beschreven verklaring is in overeenstemming met de relevante harmonisatiewetgeving van de Unie en de overeenkomstige geharmoniseerde normen	Opisany powyżej przedmiot tej deklaracji jest zgodny z odpowiednimi wymaganiami unijnego prawodawstwa harmonizacyjnego	Výše popsany předmět prohlášení je ve shodě s příslušnými harmonizačními právními předpisy Unie
--	---	--	--	---

bejelentett szervezet által kiállított igazolások	Certificate emise de organismul acreditat	Certificaten afgegeven door de aangemelde instantie	W stosownych przypadkach nazwa, adres i numer jednostki notyfikowanej	Případné certifikáty vydané oznámeným subjektem
---	---	---	---	---

		SSV8500	DGR-0036-QS-955-23	
		SSV8600	CE-0085CO0198	
		SSV8500	CE-0085CO0044	
		SSV8600	CE-0085CO0198	
			CE-0085CO0044	
			C3A 070229 0009	

Kiállítás helye és dátuma	Locul și data emiterii	Plaats en datum van uitgifte	miejsce i data wydania	Místo a datum vydání
---------------------------	------------------------	------------------------------	------------------------	----------------------

Név, beosztás, aláírás	Nume, funcție, semnătură	Naam, functie, handtekening	Nazwisko, stanowisko, podpis	Jméno, funkce, podpis
------------------------	--------------------------	-----------------------------	------------------------------	-----------------------

General Features

APPLICATION

The safety shut-off valve (SSV) of 8600 series is a self-operated, direct acting, spring loaded safety device designed for use in gas distribution and pressure regulation systems with network pressure up to 25 bar.

PRODUCT DESCRIPTION

SSV8600 protects the downstream pipe against over-pressure or low pressure failures.

When the downstream pressure increases or decreases beyond the pre-adjusted values the safety shut-off valve interrupts immediately the gas flow.

The device operates with a diaphragm control unit and is fitted with an external manual reset of lever type. The integrated by-pass system and levers mechanism allow easy resetting of the shut-off valve. Device is also equipped with a button for manual voluntary intervention.

As option, SSV 8600 can be fitted with remote position indicator (reed contact type) to provide an information about "opened" or "closed" position of SSV.

SSV 8600 has an application as solo version or as integrated in regulator (upstream side), but independent safety device (example: RB4000 / 4700 / 4600 Series regulators).

This type of safety devices is produced and tested according to the product standards EN14382 and requirements of Pressure Equipment Directive 2014/68/EU.

TECHNICAL FEATURES

- Inlet pressure range P zul : 25 bar (Steel body)
19,2 bar (Cast iron body)
- Over pressure shut-off range (OPSO): 0,028 - 20 bar
- Low pressure shut-off range (LPSO): 0,05 - 5.0 bar
- Accuracy class OPSO: AG 5 up to AG 1
LPSO: AG20 up to AG2.5
- Temperature range -20°C to + 60°C
- Acceptable gases Natural gas, town gas, propane, butane, air, nitrogen, hydrogen (up to 30%) or any non-corrosive gas. Use only for dry and clean gas. Never use with oxygen.
- Installation Any orientation

CONNECTIONS

- Sizes DN 25 / 40 / 50 / 80 / 100
(Body lengths according to EN 334)
- Type Flanges (according to ISO 7005):
cast iron PN16 / 25/ ANSI 150 (PN20) RF
cast steel PN16 / 25/ ANSI 150 (PN20) RF

MATERIALS

- Body Cast- iron spheroid graphite EN-GJS-400-18LT
Cast steel G20Mn5N
- Casing and cover Aluminium or Steel
- Diaphragm Rubberised Fabric
- O-rings NBR / Viton
- Valve plug Stainless steel / NBR
- Other internal parts Stainless steel and Brass

SPRING SELECTION TABLES

OVER PRESSURE SHUT-OFF SPRINGS / OPSO

Characteristics of the springs					Who (mbar)	Who (bar)				Colour
Code	d mm	De mm	Lo mm	lt	8611/12 (ø 150)	8621/22 (ø150/TR)	8631/8632 (ø 90)	8641/8642 (ø 90/TR)		
20565233	2.2	35	60	7	28 ÷ 65				Yellow	
20565234	2.5	35	60	7	45 ÷ 100				Red	
20565330	2.7	35	60	7	80 ÷ 140				White	
20565331	3	35	60	7	100 ÷ 240		0.60 ÷ 0.90		Blue	
20565332	3.5	35	60	7	190 ÷ 350	0.55 ÷ 0.90	0.90 ÷ 1.4		Orange	
20565333	4	35	60	7	350 ÷ 700	0.90 ÷ 1.70	1.40 ÷ 2.40	2.30 ÷ 4.10	Brown	
20565334	4.2	35	60	7	450 ÷ 800	1.50 ÷ 2.00	2.00 ÷ 3.10	3.10 ÷ 5.00	Green	
20565430	4.5	35	60	7	600 ÷ 1000	1.70 ÷ 2.30	2.50 ÷ 3.90	3.80 ÷ 6.00	Black	
20565431	5	35	60	7	950 ÷ 1300	2.30 ÷ 3.00	3.90 ÷ 4.60	5.70 ÷ 7.50	Grey	
20565432	5.5	35	60	7	-	-	4.60 ÷ 6.30	7.50 ÷ 10.00	Yellow	
20565134	6	35	60	7	-	-	6.30 ÷ 10.80	10.00 ÷ 20.00	Red	



LOW PRESSURE SHUT-OFF SPRINGS / LPSO

Characteristics of the springs					Whu (mbar)	Whu (bar)				Colour
Code	d mm	De mm	Lo mm	lt	8611/12 (ø 150)	8621/22 (ø150/TR)	8631/8632 (ø 90)	8641/8642 (ø 90/TR)		
20561124	1.2	15	40	10	5 ÷ 18	-	-	-	White	
20561221	1.5	15	40	10	10 ÷ 55	-	-	-	Blue	
20561222	1.7	15	40	10	30 ÷ 75	0.11 ÷ 0.29	0.23 ÷ 0.37	0.32 ÷ 0.63	Orange	
20561223	2	15	40	10	60 ÷ 150	0.16 ÷ 0.49	0.26 ÷ 0.66	0.42 ÷ 1.10	Brown	
20561224	2.5	15	40	10	100 ÷ 250	0.21 ÷ 0.74	0.32 ÷ 1.00	0.60 ÷ 2.20	Green	
20561321	2.8	15	35	7	-	-	-	2.20 ÷ 5.0	-	

OPERATIONAL SCHEMATIC

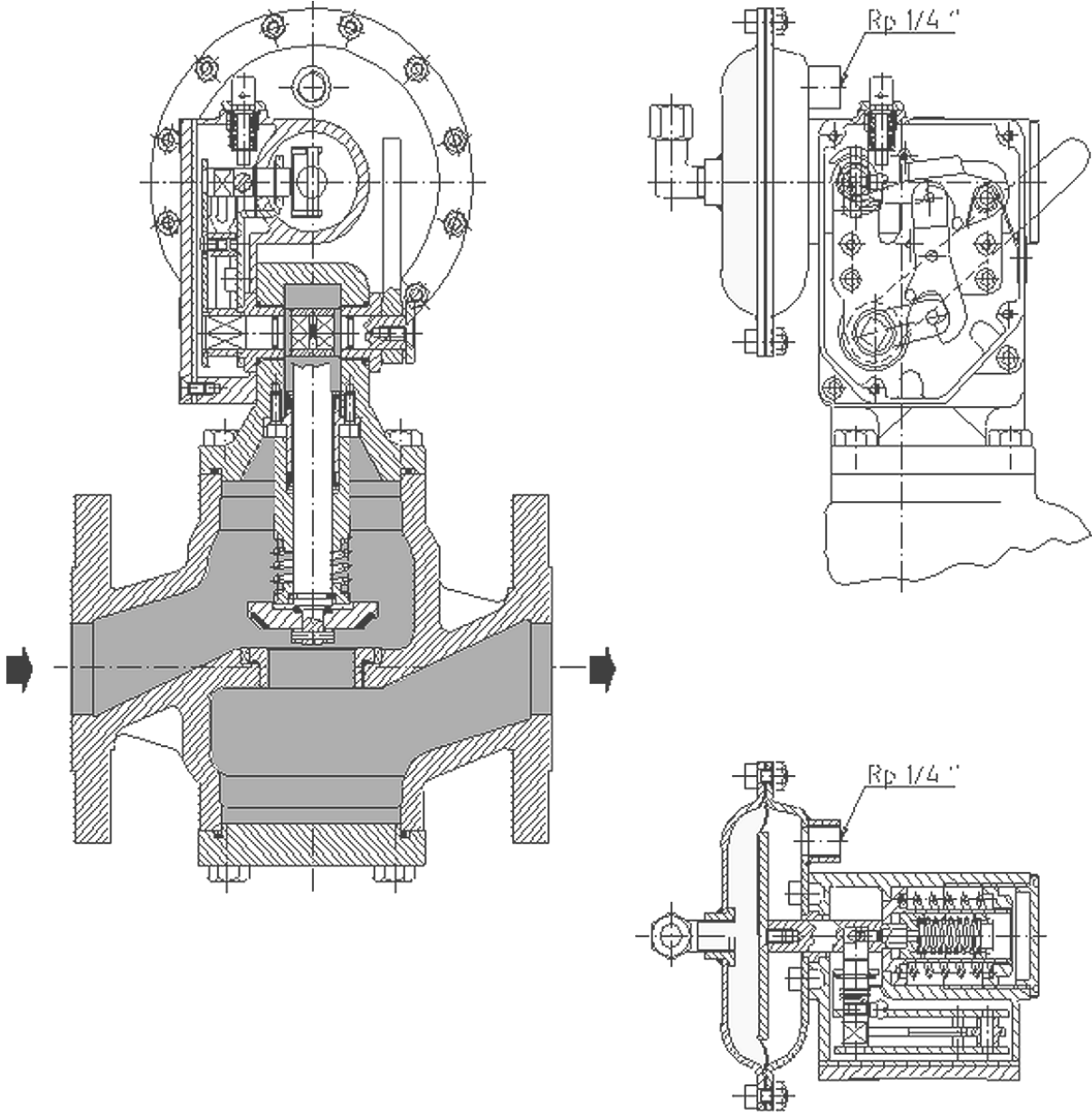
Figure 1



-  - Inlet pressure
-  - Outlet pressure

Solo SSV 8600

Figure 2

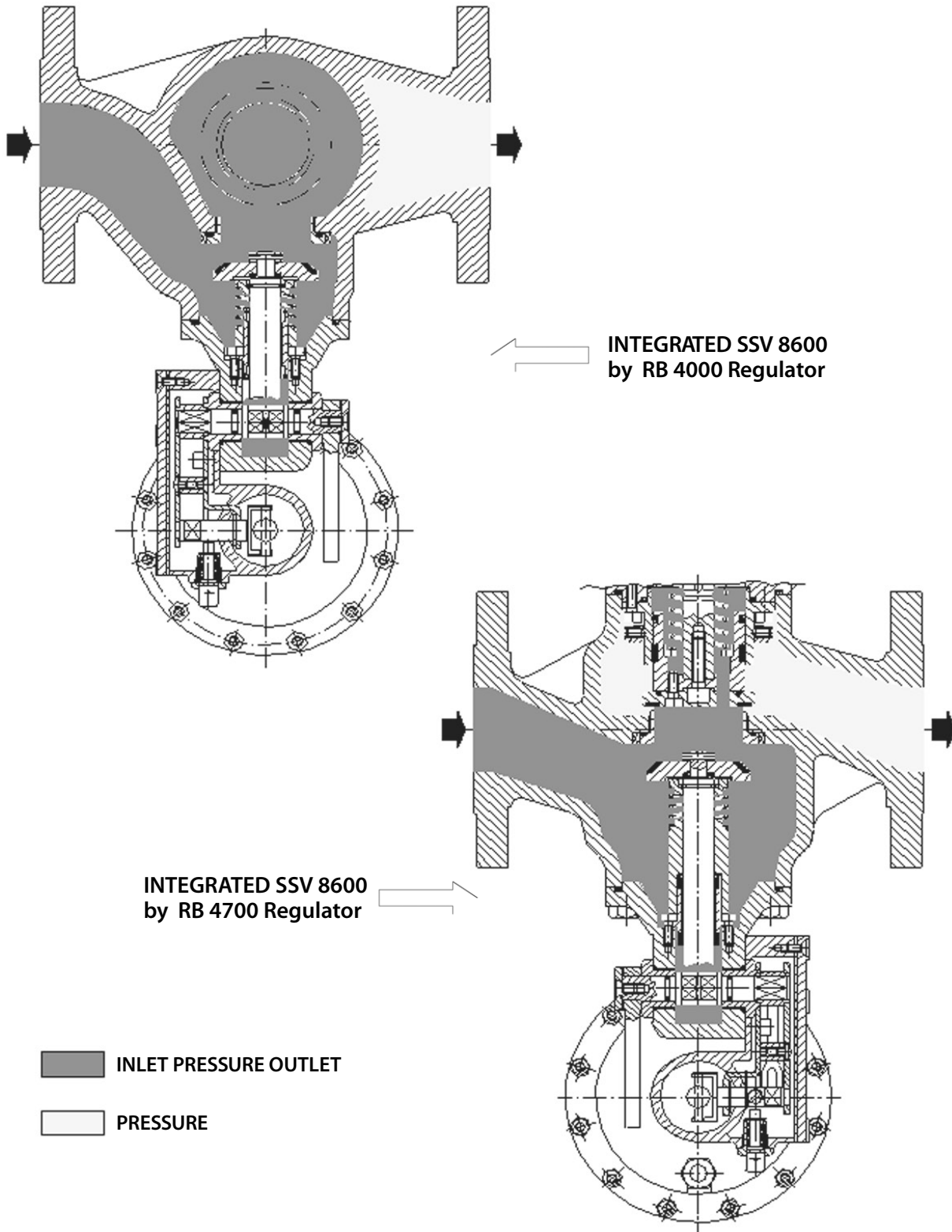

OVERALL DIMENSIONS AND WEIGHTS

Figure 3

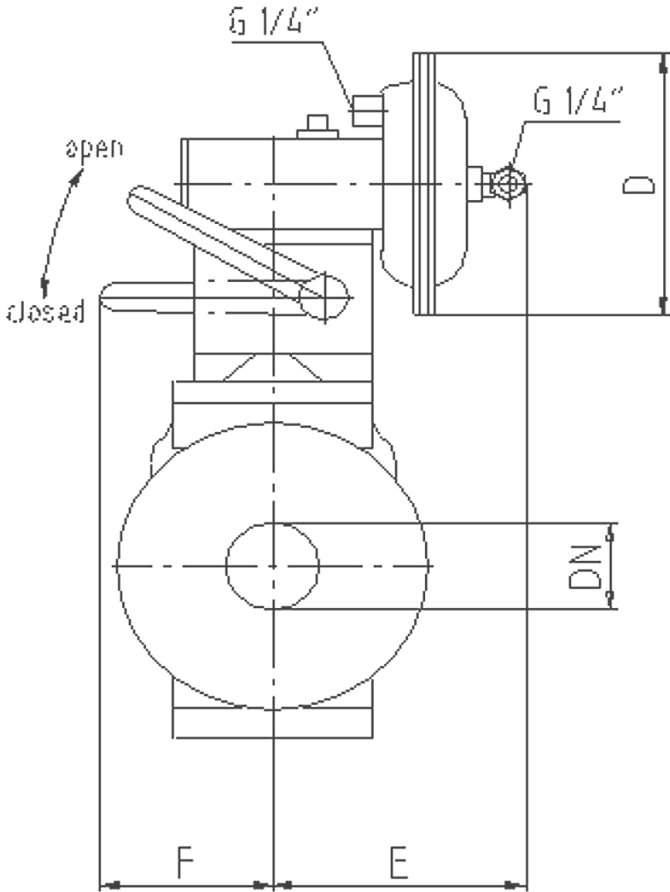
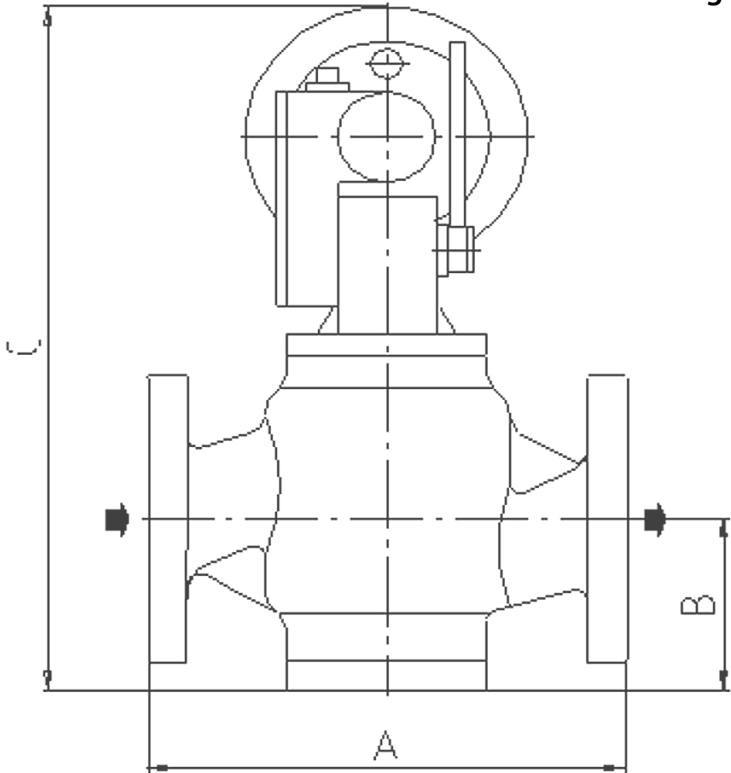

(dimensions are given in mm)

DN Size	Dimension	Model	
		8611 / 8612 8621 / 8622	8631 / 8632 8641 / 8642
DN 25	A	184	184
	B	62	62
	C	338	308
	D	150	90
	E	120	120
	F	100	100
	Weight, kg	14	14
DN 40	A	222	222
	B	87	87
	C	373	343
	D	150	90
	E	120	120
	F	100	100
	Weight, kg	21	21
DN 50	A	254	254
	B	98	98
	C	393	363
	D	150	90
	E	120	120
	F	100	100
	Weight, kg	23	23
DN 80	A	298	298
	B	122	122
	C	468	438
	D	150	90
	E	120	120
	F	100	100
	Weight, kg	43	43
DN 100	A	352	352
	B	132	132
	C	452	422
	D	150	90
	E	120	120
	F	100	100
	Weight, kg	67	67

OPERATION

Sectional View

Figure 4

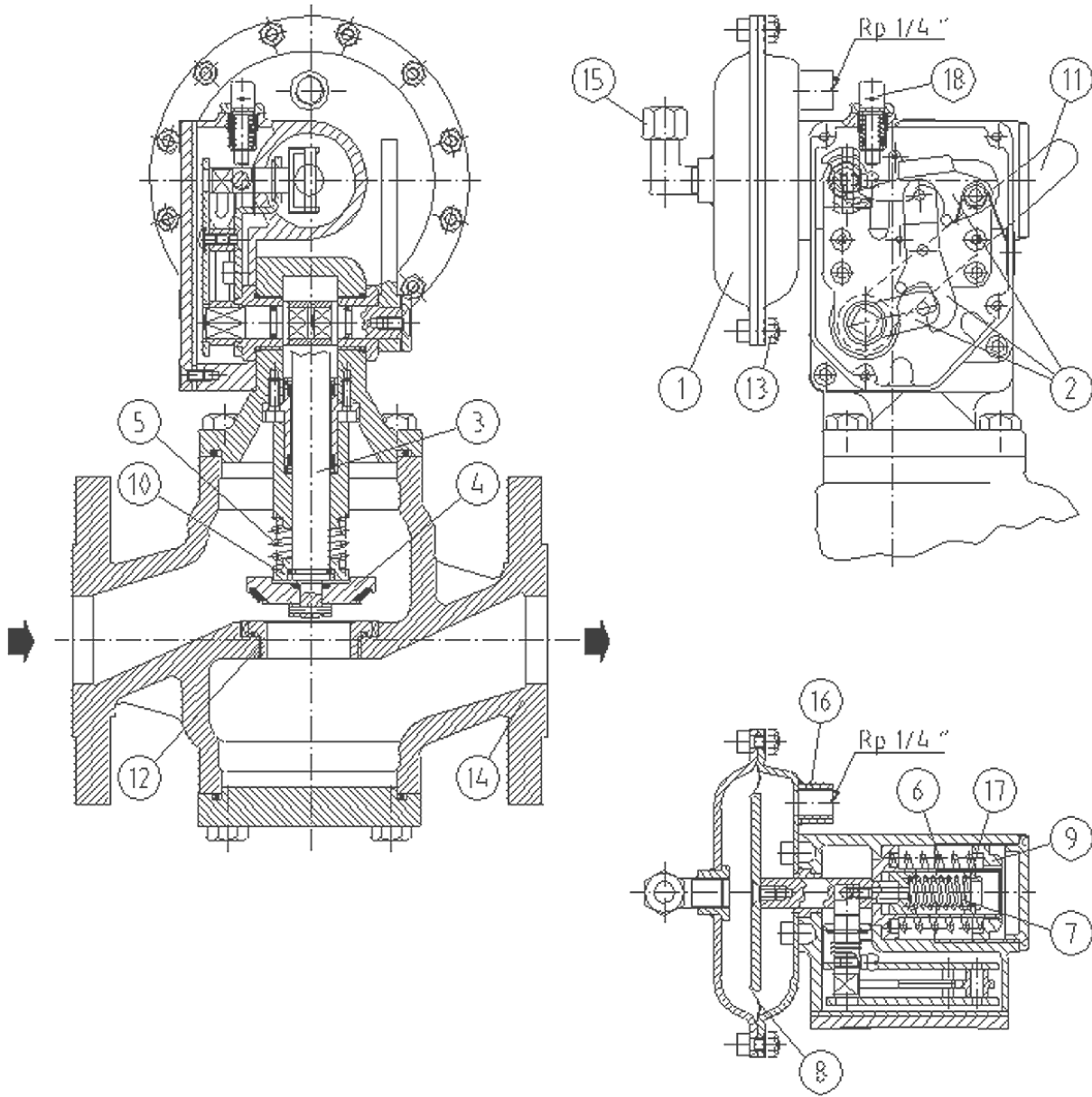

SSV OPERATING PRINCIPLE

Safety Shut-off Valve 8600 (SSV 8600) is designed as independent safety device in order to protect the downstream pipe against over- or under-pressure failures by immediately stopping of the gas flow. This happens as soon as the downstream pressure reaches the pre-adjusted over pressure (OPSO) or under-pressure (LPSO) set points.

The SSV is open in the normal working conditions.

The pressure to be controlled is entering through the impulse intake (15) to the shut-off control chamber (1) above the diaphragm (8). In this chamber the downstream pressure is compared with the pre-adjusted set values for over pressure- (spring 6) and low pressure shut-off (spring 7).

The diaphragm (8) is moving from the balanced position as soon as the controlled pressure increases or decreases beyond the established (pre-adjusted) values. This causes rotation of the control levers (2), which trip from the fixed position and release immediately the stem group (3) - valve plug (4) assembly. Under the force of the closing spring (5), the valve plug (4) is brought in the contact with the valve seat (12) and the flow of gas is immediately interrupted.

After closing of SSV no self- or remote resetting is possible. This can be done only manually and directly on the field.

As option, Safety Shut off Valve can be fitted with remote position indicator (reed contact), which schematic sketch and application example are shown on the Figure 5 and 6. This device allows to get an information about closed or open position of SSV.

The shaft coming from SSV is linked to the shaft of position indicator having an integrated magnetic element (19). In normal case SSV is in the opened position. As soon as the SSV closes, the shaft (19) turns and its magnetic element comes close to the read contact. The read contact closes the current circuit and the tension generated by installed externally control unit increases. This tension increase is evaluated as output impulse.

In opposite case (SSV is resetted), the contact of magnetic element with reed contact disappears (SSV shaft is turned). The circuit is interrupted and no impulse is more generated.

Item	Description
1	Shut-off control chamber
2	Levers system
3	Stem
4	Valve plug
5	Closing spring
6	OPSO adjustment spring
7	LPSO adjustment spring
8	Diaphragm
9	OPSO adjustment nut

Item	Description
10	By-pass
11	Resetting lever
12	Valve seat
13	Screws
14	Body
15	Sensing line
16	Breathing vent
17	LPSO adjustment nut
18	Button for voluntary intervention

REMOTE POSITION INDICATOR (REED CONTACT)

Item	Description
19	Shaft with magnetic element
20	Connector

Figure 5

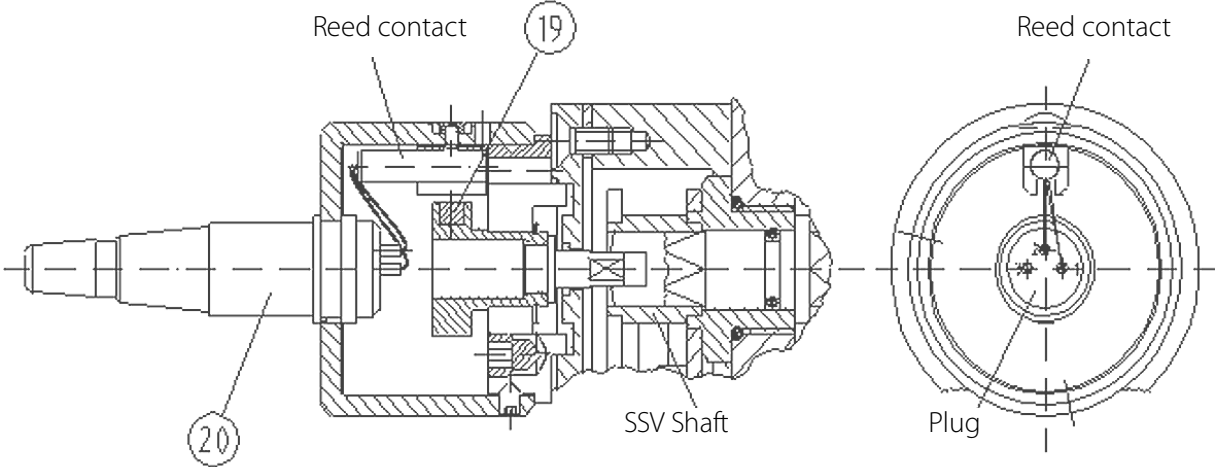
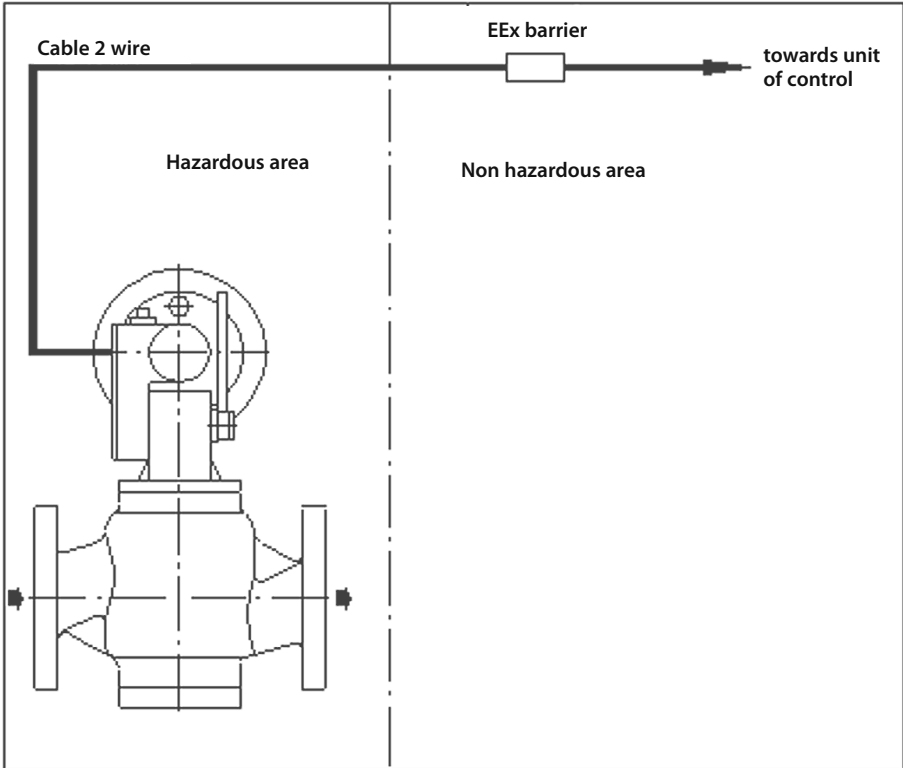

Figure 6



REMOTE POSITION INDICATOR (REED CONTACT) ASSEMBLY ON THE FIELD:

Remote position indicator can be delivered as "Assembly Kit" and mounted on Safety shut-off device directly on the field. This has to be done in the following way (items mentioned below refer only to Figure 7):

- a) Manually trip the Safety Shut-off valve by the mean of button for voluntary intervention (see Figure 4), so that it is in the closed position;
- b) Remove existing SSV cover (1) by unscrewing 4 screws and removing the gasket;
- c) Insert slightly greased O-ring (2) and coupling (3) in the hole of the new cover (1);
- d) Install gasket and new SSV cover assuring by rotating that the coupling (3) is set into the SSV pinion (4), tighten all 4 cover screws;
- e) Install the mounting flange (5) into the hole of the cover, take care to set the end of the coupling (3) in the magnetic rotor (square ends match up);
- f) Tighten the flange set screw (6) to about 5 Nm, the flange should not move or turn by hand
- g) Place the switch housing (7) over the flange (5) and lightly tighten the two small set screws (8), so that you can still rotate the housing by hand;
- h) Connect a continuity tester or directly your control device to the plug to pins 1 and 2 (see Figure 5);
- i) Rotate the switch housing (7) until the tester indicates a closing. This position is the one in which the magnet in the rotor is lined up with the Reed switch;
- j) Hold this position of the switch housing (7) and tighten the 2 set screws (8) until the housing cannot be turned by hand;
- k) The retro-fitting is now complete. Test the mounting by resetting the Safety shut-off device, so that it is in the "open" position: no contact should be indicated! Trip again manually the Safety shut-off valve, now the contact should be indicated.

Figure 7

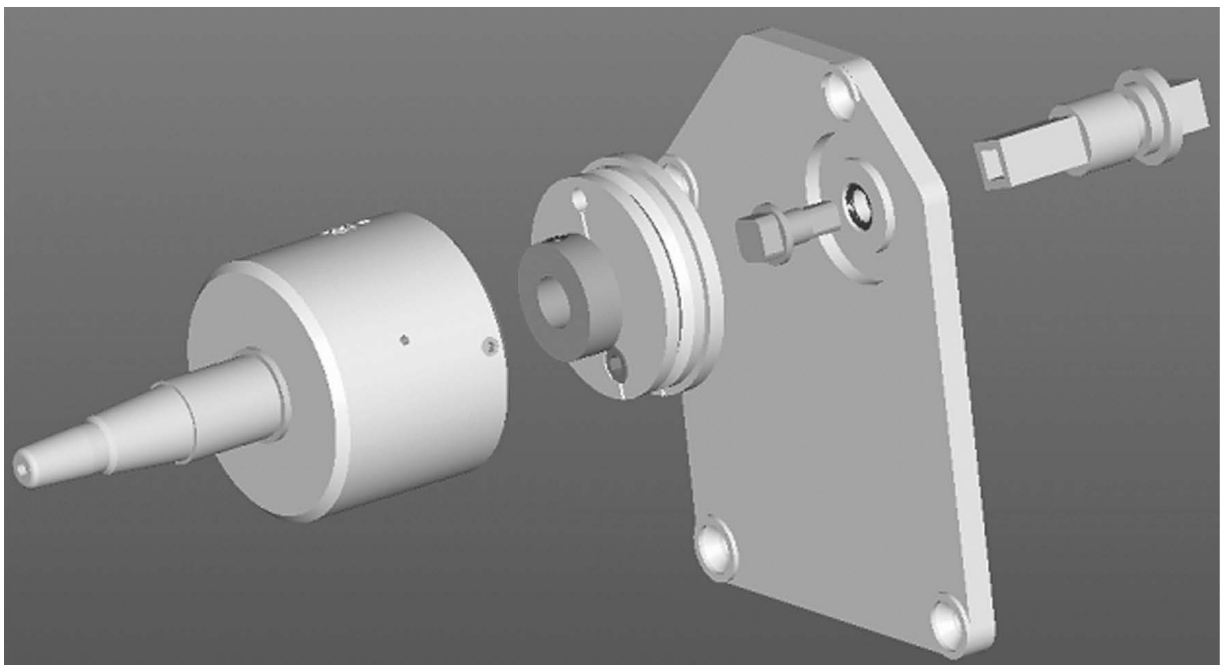

Installation

All delivered Safety shut-off valves SSV 8600 are produced, checked for resistance and tightness and adjusted in accordance with the requirements of Pressure Equipment Directive 2014/68/EU.

In any case the acting national norms and standards about installation, start-up and maintenance of the safety devices and gas installations have to be strictly respected.

The handling with the safety shut-off valve has to be done carefully.

The pick up has to be made by using the stretcher eyes or belts.

Installing of the device in the piping must be performed by respecting the following points:

- the upstream and downstream flanges have to be parallel and the safety device must be capable of being fitted without any mechanical stress;
- the mentioned below torque's values for screws must be respected by tighten of the flanged connections:

	DN25	DN40	DN50	DN80	DN100
PN16	35Nm(M12)	85Nm(M16)	85Nm(M16)	85Nm(M16)	85Nm(M16)
ANSI150	55Nm(M14)	55Nm(M14)	85Nm(M16)	85Nm(M16)	85Nm(M16)
PN25	35Nm(M12)	85Nm(M16)	85Nm(M16)	85Nm(M16)	170Nm(M20)

- these torque's values are mentioned per screw and are valid for metal soft material gaskets (specified as $k_0 \times k_D = 45b_D$ und $k_1 = 2,2b_D$); other gaskets can require other torque's values.
- the screws used for the flange connection must be according to the flange size and must be adapted to the temperature range of the SSV; please tighten the screws crosswise.
- the upstream piping and connecting lines have to be cleaned from all possible impurities (welding slag, sand, etc..) to prevent any damage of safety device and function failure;
- to check if the safety device is not visibly damaged (for example after transportation); possible lacquer damage should be improved; the sealing surfaces of the flanges must be damage-free and clean;
- the inlet and outlet chambers of the safety device body have to be also perfectly clean;

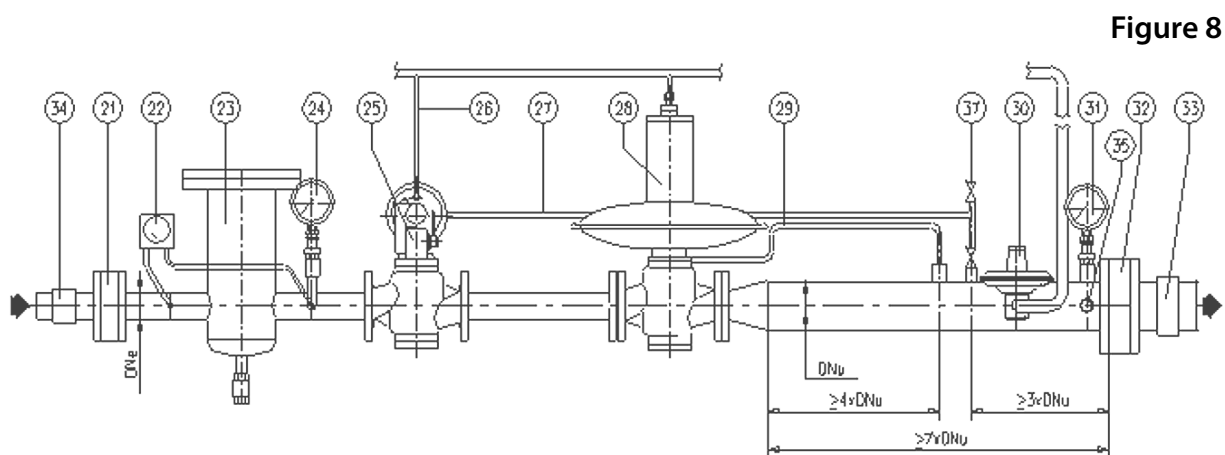

- the functional characteristics indicated on the name plate must correspond to the installing and operating conditions;
- direction of gas flow has to correspond to the arrow on the safety device body.

Figure 9

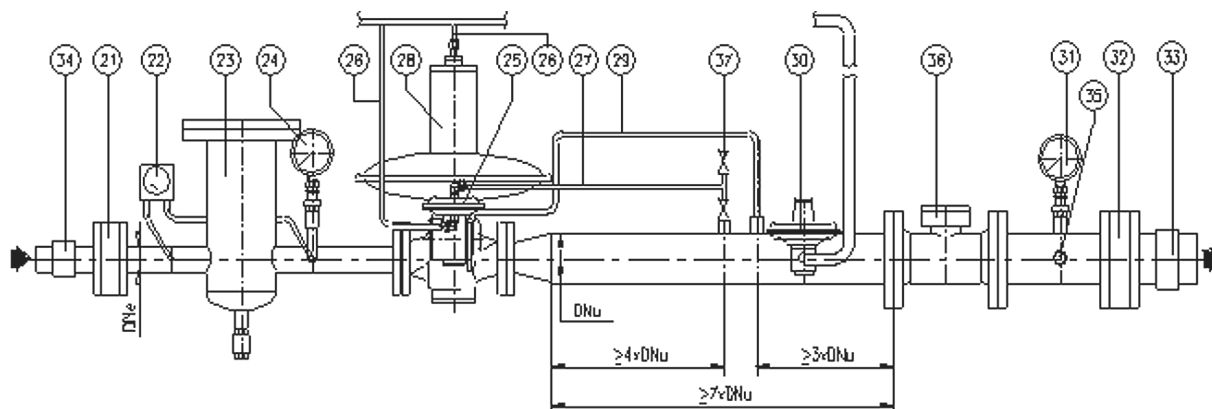

Figures 8 and 9:

Position	Description
21	Upstream valve
22	Differential pressure manometer
23	Filter
24	Upstream manometer
25	Safety shut-off valve
26	Breathing line
27	Impulse line (SSV)
28	Regulator
29	Impulse line (Regulator)
30	Safety relief valve (SRV)
31	Downstream manometer
32	Downstream valve
33	Downstream isolating connection
34	Upstream isolating connection
35	Discharge vent
36	Meter
37	Pressure intake tap

The Safety shut-off valve can be installed in the horizontally or vertically.

The device should be not impaired in its function by other installation components. In particular the effectiveness/ operability must be ensured by measuring and breathing lines each time.

To install the safety device the following should be provided:

- an electrically insulating joint upstream and downstream, if the incoming and outgoing piping are made from ferrous material;
- an on/off valve on the upstream and downstream side of the piping;
- sensing line of the safety device has to be connected to the turbulence free zone of the downstream side;
- breathing lines (by indoor installations);
- a manometer or pressure gauge on the upstream and downstream side of the piping;
- an upstream filter;
- a pressure intake downstream for start-up and changes in pressure setting;
- electrical earthing of the unit;
- free passage for service, reading of the name plates and maintenance operations; -all variations in diameter downstream must be performed progressively in order to prevent
- negative turbulence of the gas flow.
- vent lines, as for codes of practice

REMARKS FOR USE IN POTENTIALLY EXPLOSIVE ATMOSPHERES (ATEX):

- If film of rust is possible (flying rust in the immediate regulator surroundings), all outer aluminium parts have to be protected accordingly (e.g. by varnish).
- The product must be electrically connected to adequately earthed installation.
- For installation, removing or repair of the regulator on site, only tools allowed for the corresponding explosion area can be used.
- The regulator shall not be exposed to: flames, ionised radiation and ultrasound.
- Ambient temp. conditions must be considered, including possible additional heating effects due to other devices in immediate vicinity.
- Safety devices according DIN EN 14382 - if not equipped, with any electronic device – do not have a potential ignition source and therefore are not in the scope of European directive 2014/34/EU.

To connect the sensing lines:

We recommend to use for impulse sensing lines the 8/10 pipe, which is connected to the angle (WE10-P/LR) impulse intake (15) and on the downstream pipe to the pressure intake (plug connection DN 1/4 ") as shown on the Figure 10. These connections must be inserted in a straight section of the downstream pipe.

For this purpose we recommend welding the impulse connections on the upper part of the piping in order to prevent impurities and condense, which can be collected and obstruct the passage of the gas. It is also important to make sure that the impulse sensing line slopes slightly downwards to the pipe.

For adequate operation, the gas velocity at the impulse position in the pipe, must not exceed the following values:

Low pressure	< 200 mbar	15 - 20 m/s
Medium / high pressure	> 200 mbar	20 - 40 m/s

After installing of the safety device and connecting of all pressure lines (including breathing lines if required), the complete system has to be checked for tightness.

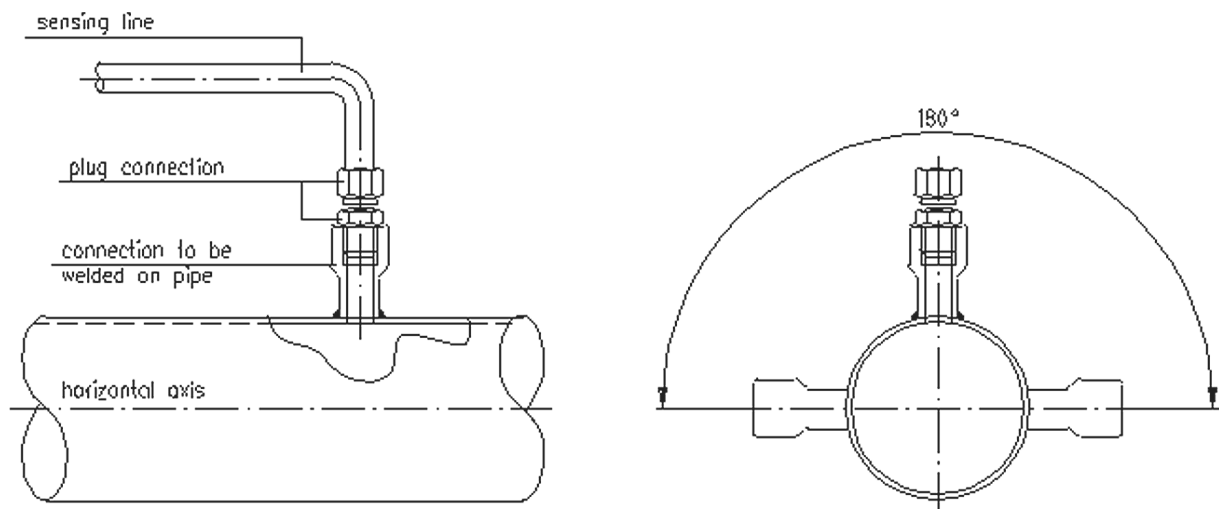

Figure 10

Start-up

COMMISSIONING / RESSETTING OF THE SAFETY SHUT-OFF VALVE

Safety shut of valve SSV8600 can be delivered having only OPSO function (over pressure shut-off) or both OPSO + LPSO (over and low pressure shut-off). To identify the delivered model refer please to "Selection of the SSV 8600 models" on page 5.

SSV having only OPSO safety is normally before use in the "opened" position and ready to start-up. SSV having both OPSO and LPSO function is should be in "closed" position before any use. Therefore re-setting has to be done to start-up.

If the safety valve has been shut-off (in network) reset must be made only after verifying the reasons for the intervention and after having re-established normal working conditions.

In such case commissioning and reset must be done as follows (see Figures 8 and 11):

- a) close the downstream stop valve (32);
- b) open the taps of the manometers (24) and (31);
- c) if necessary discharge remaining downstream pressure by the mean of discharge vent (35);
- d) check the internal tightness of SSV valve plug by opening the vent (37) (test with soap blows);
- e) slowly operate the resetting lever (42) clockwise until the internal by-pass (41) is open: with this operation pressure fills the downstream pipe, control chamber (38) and equilibrates the pressure on the both sides of valve plug (40). This can be checked on the manometer (31) of the downstream side (increase of the pressure);
- f) when the pressure indicated on the manometer (31) is stabilised, continue to move the lever (42) in order to permit the fixation of the control levers (39).
At this point the lever (42) will remain stable in the "opened" position.
- h) After above operations (a - f) have been made, the Shut-off valve is into operation and it is possible to proceed slowly with opening of the downstream valve (32).

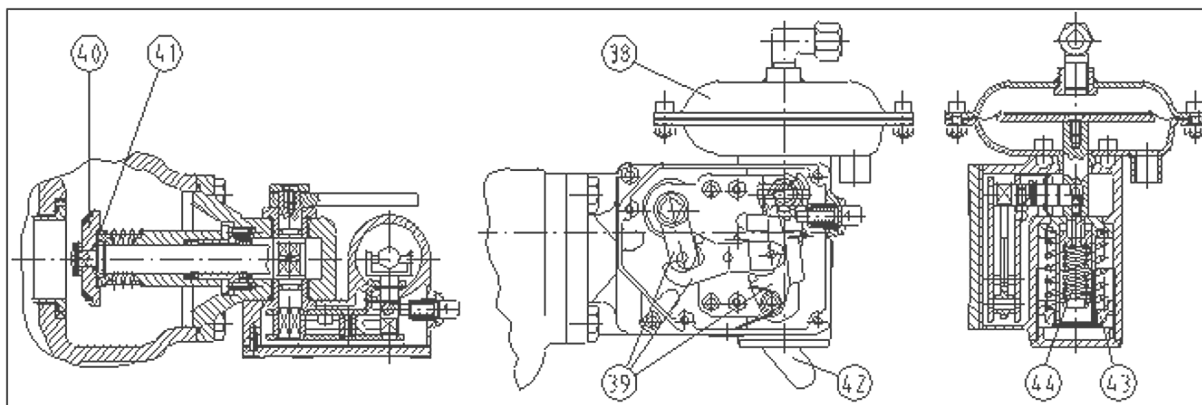

Figure 11

SETTING

The Safety shut-off valve is supplied with set points specified in the order.
The set point can be adjusted in the range mentioned in the “spring selection table”.

When the installed spring is appropriate to obtain the required pressure, proceed as follows (Figures 8 and 11):

- **Over-pressure shut-off (OPSO):**
 - a) close the downstream valve (32) and increase progressively the downstream pressure till reaching the required value for OPSO;
 - b) to change this value, rotate in a clockwise direction the external screwing ring (43) in order to increase the calibration value or in an anticlockwise direction to reduce it.

- **Low-pressure shut-off (LPSO):**
 - a) close the downstream valve (32) and exhaust progressively the downstream pressure till reaching the required value for LPSO;
 - b) to change this value, rotate in a clockwise direction the internal screwing ring (44) in order to increase the calibration value or in an anticlockwise direction to reduce it.

Important: The changing of the setting of the shut-off valve must always be performed with the diaphragm control unit (38) under pressure.

To verify the adjusted set points, actuate the Safety shut-off valve two or three times checking that it springs up to the required pressure value.

Maintenance

Maintenance and repairs of the device are allowed to be made only by trained or qualified personal. Afterwards a tightness test with 1.1 X PS must be performed.

When changing pressure containing parts their compliance with PED must be assured.

After Guarantee only with repair by Dresser Actaris Gas.

The maintenance works required for the Safety shut-off valve are closely linked to the quality of gas supplied (moisture content, liquid hydrocarbons, impurities in general) and the degree of filtration performed upstream of the safety device.

For this reason, we recommend always installing of a cartridge filter upstream of the safety device, which is capable of withholding the solid and liquid particles present in the gas.

We also recommend performing routine preventive maintenance at established intervals in accordance with:

- the quality of the gas supplied;
- importance of the service rendered,;
- reliability required;
- condition and cleanliness of the piping that supplies the gas to the system.

Recommended maintenance intervals (can differ depending on the above listed factors) are mentioned in the table here below :

Maximum upstream pressure	Maximum flow capacity	Monitoring			
		Visual control	Inspection	Functional check	Maintenance
bar	m ³ /h				
≤ 0,1	-	As requested			
> 0,1-1	≤ 100	As requested		twelve-annually	As rested
	> 100			four-annually	eight-annually
> 1-4	≤ 100	As requested		six-annually	As rested
	> 100			two-yearly	four-annually
> 4-16		quarterly	half-yearly	annually	two-yearly
> 16-100		monthly	quarterly	half-yearly	two-yearly

- The device has to be also regularly examined for corrosion danger in the interior and external area and be taken from use if noticeable corrosion is discovered.
- The device must be cleaned with a wet cloth only. Do not use any alcohol containing solvent or cleaning agents.

All pressures must be discharged before performing any maintenance operation on the safety device!

Proceed in the following way (see Figures 8 and 1):

- a) close the on/off valves upstream and downstream (21) and (32);
- b) slowly discharge the pressure by opening the discharge vent (35) downstream from the safety device till the downstream manometer (31) shows "0" value;
- c) if safety device is equipped with over- and lower-pressure shut off (OPSO + LPSO), use the resetting lever (42) to open the by-pass (41) between the inlet and outlet chambers (see the paragraph "Commissioning / Resetting of the safety shut-off valve".
This permits the discharge of pressure upstream of the safety device that is otherwise kept by the intervention of the low pressure shut-off (LPSO).

Before to start the maintenance works:

- d) be sure that all required wrenches and other necessary tools are close at hand to perform the operations;
- e) spare parts to replace the damaged one are immediately available.

During the maintenance works:

- f) disassemble all parts carefully in order to avoid any damage;
- g) pay extra attention to the rubber parts (by using appropriate tool for the disassembly of the O-rings);
- h) replace all parts that exhibit even the slightest signs of damage.

In the event of malfunction check the trouble-shooting diagram to identify the cause of the malfunction.

TROUBLE SHOOTING

Figure 12

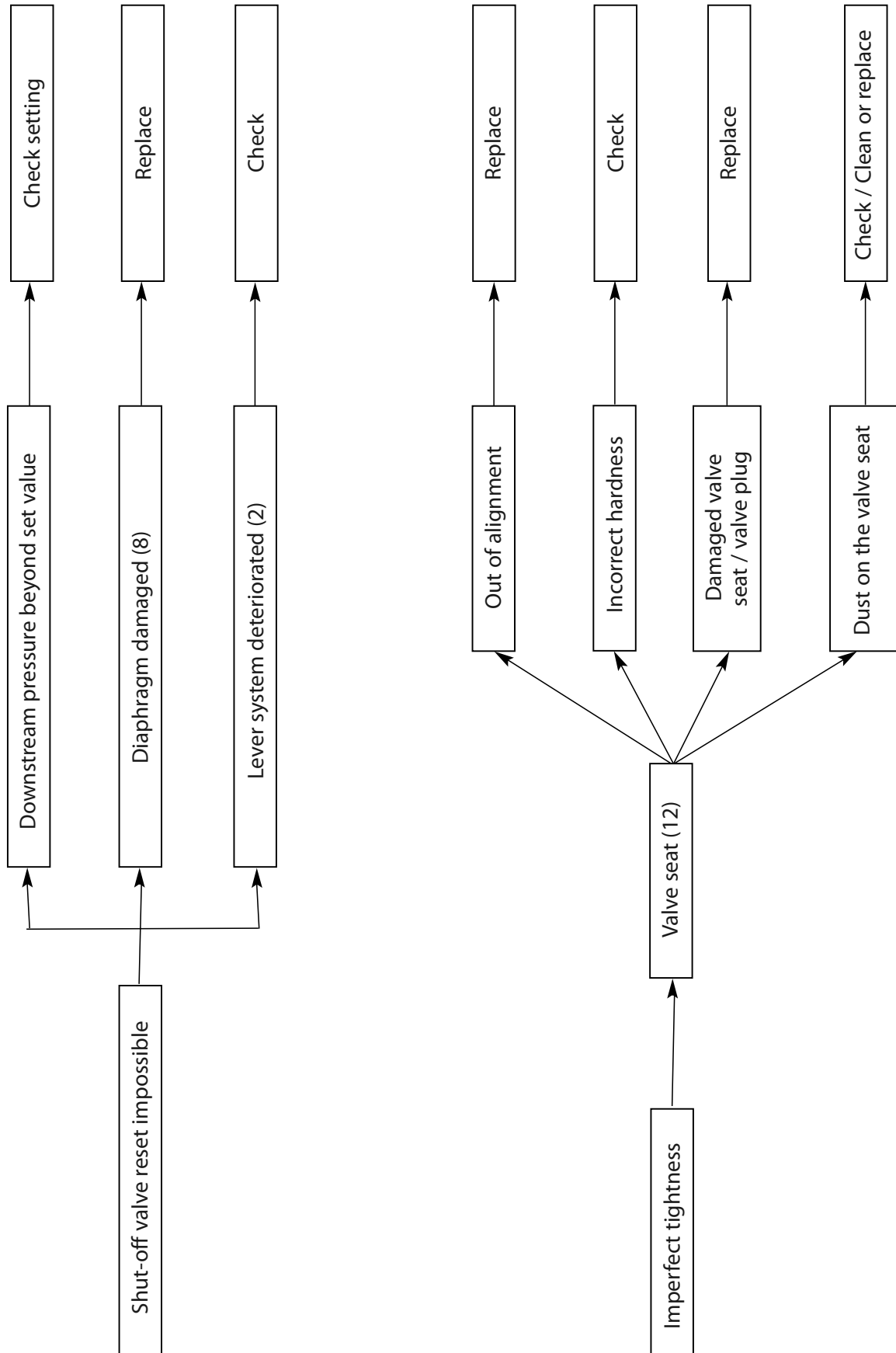

Figure 13

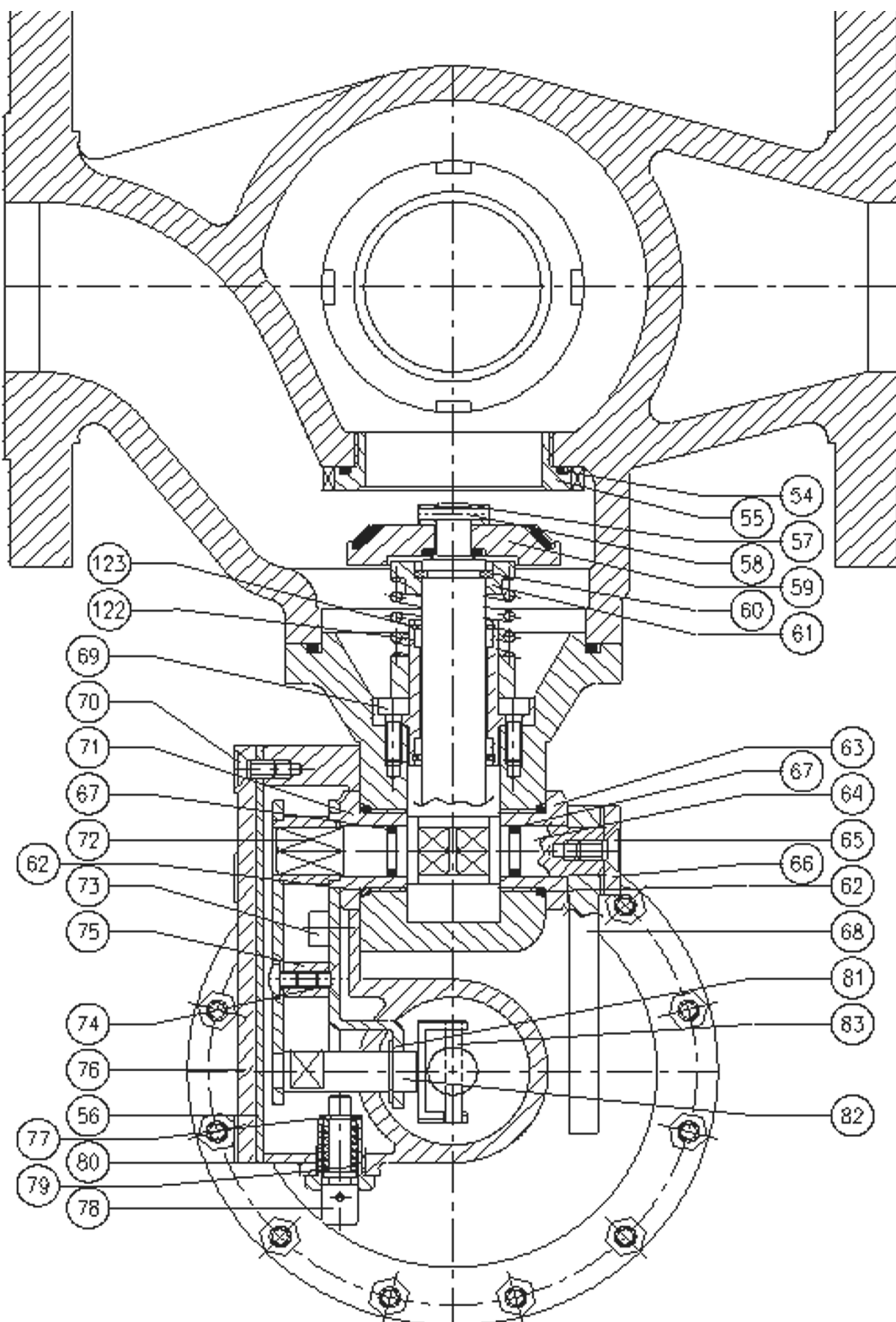
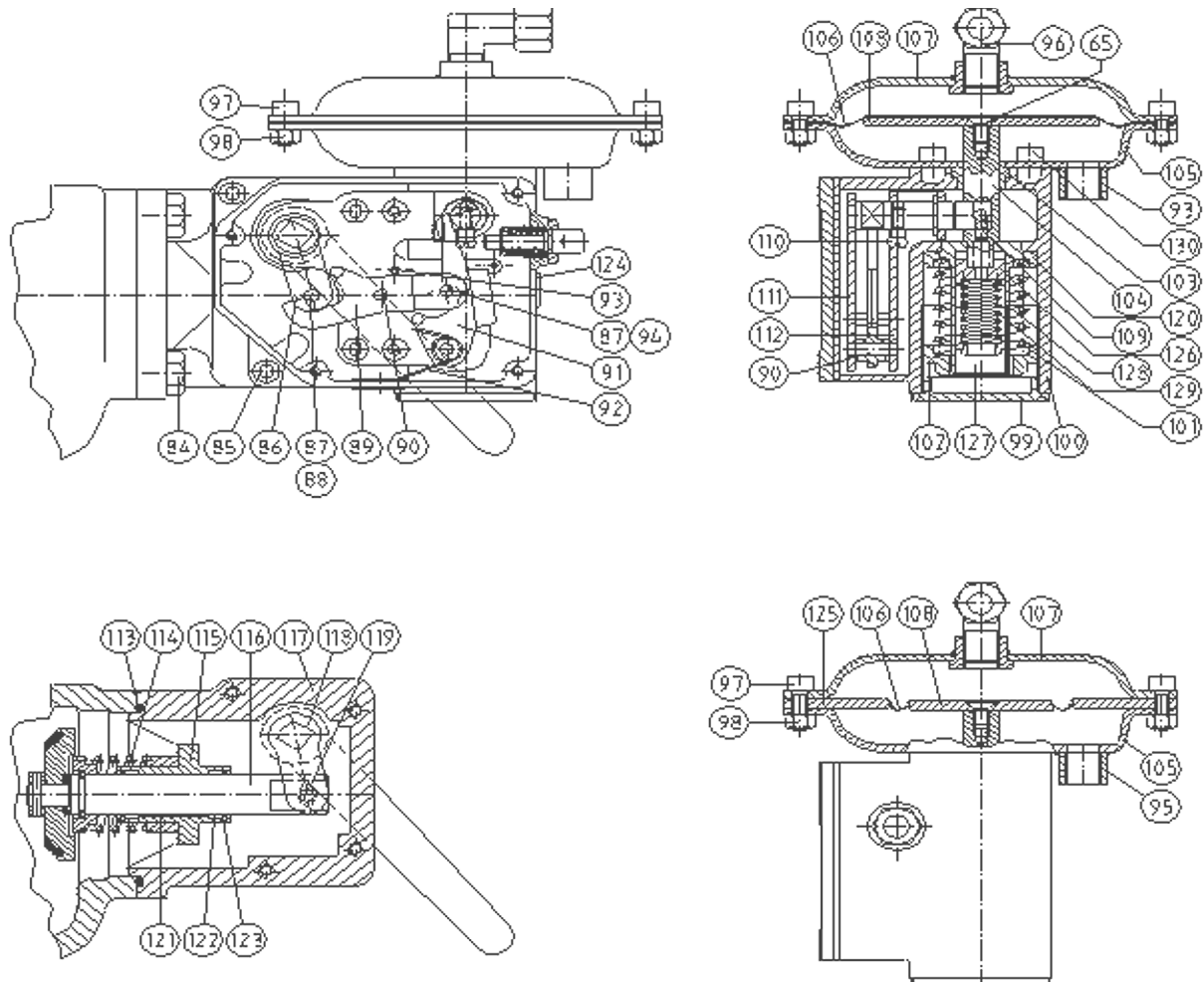

Figure 14



54	O-ring
55	Valve seat
56	Gasket
57	Safety washer
58	Flexible pin
59	Valve plug
60	Safety washer
61	Spring guide
62	O-ring
63	Plug
64	SSV reset stem
65	Screw
66	Washer
67	O-ring
68	Resetting lever

69	Screw
70	Screw
71	Plug
72	SSV reset stem Screw
73	Screw
74	Screw
75	Brace
76	Cover
77	Snap ring
78	Manual resetting button
79	Spring
80	Plug
81	Seeger ring
82	Lever
83	Pin

Figure 15

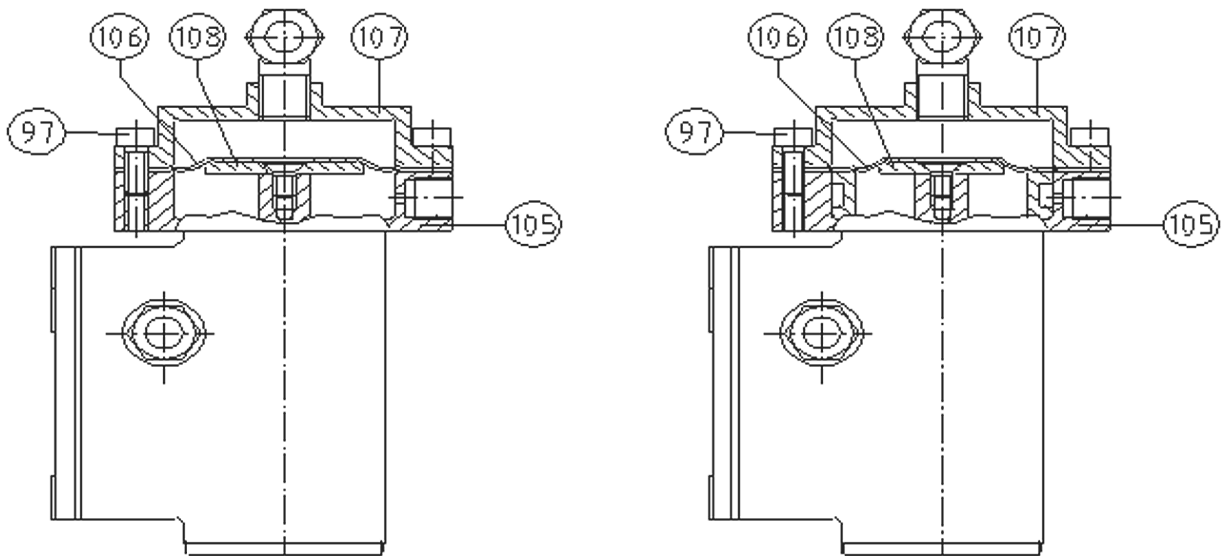

84	Screw
85	Screw
86	Lever
87	Peg
88	Roller
89	Lever
90	Pin
91	Lever
92	Spring
93	Pin
94	Roller
95	Breathing vent
96	Olive connector
97	Screw
98	Nut
99	Cover
100	SSV box
101	OPSO spring
102	OPSO adjustment nut
103	Guide
104	Stem
105	SSV bottom case
106	Diaphragm
107	SSV upper case
108	Diaphragm holder
109	Screw

110	Screw
111	Plate
112	Plate
113	O-ring
114	Closing spring
115	Guide
116	SSV stem
117	SSV body
118	Lever
119	Peg
120	Spring guide (OPSO)
121	Safety spacer
122	Bush
123	Stop ring
124	Plate
125	Reducing ring
126	Spring guide (LPSO)
127	LPSO adjustment nut
128	Bush
129	LPSO spring
130	Screw

Maintenance Tools

Type:	Tool:	DN 25	DN 40 / DN 50	DN 80	DN100
A	3				
	4	65 - 69 - 84	65 - 69	65 - 69	65 - 69
	5	85 - 97 - 130	85 - 97 - 130	85 - 97 - 130	85 - 97 - 130
	6				85 - 97 - 130
	8				
B	13				
	17				
	19				
	30	102	102	102	102
C	10	98	98	98	98
	13				
	17	80	80 - 84	80	80
	19	96	96	96	84 - 96
	21				
	22			84	
	24				
	30	63 - 71	63 - 71	63 - 71	
	32				63 - 71
	35				
	40				

Figure 17

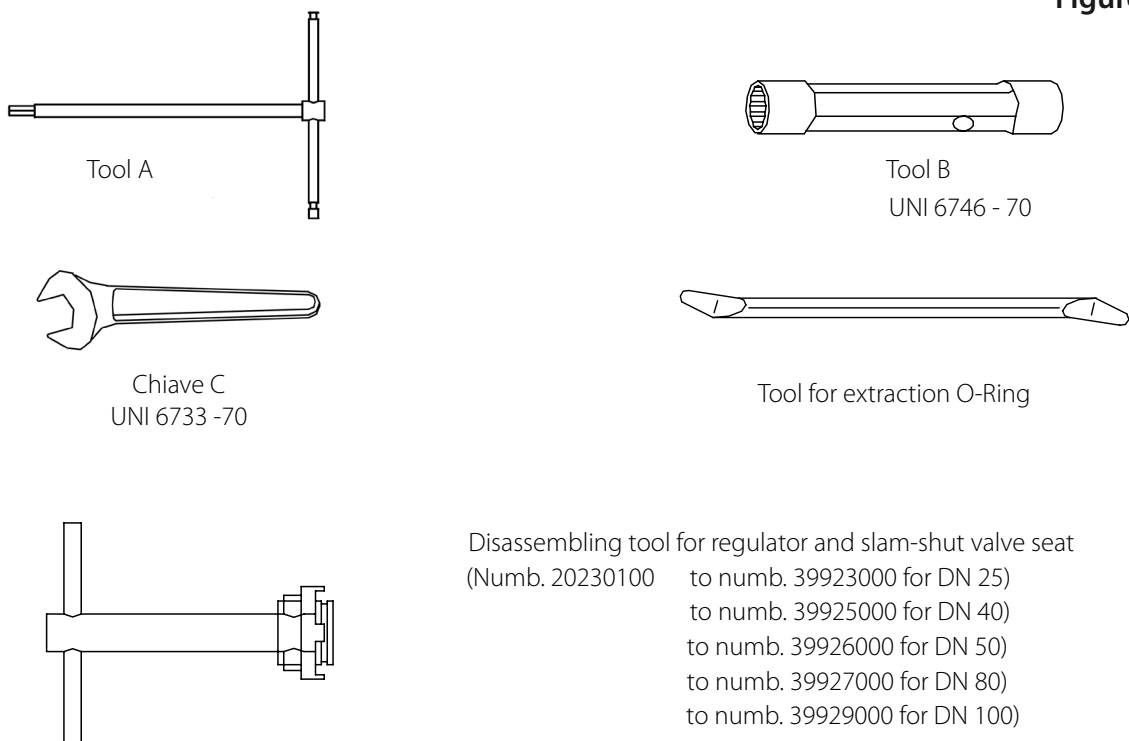

Pressure loss calculation

Pressure loss of the shut-off valve Series 8600 is a function of pressure, temperature and gas density:

$$\Delta P = (Q / C_g)^2 / P$$

where:

ΔP : pressure loss (bar)

P : absolute working pressure (bar)

Q : flow rate referred to normal conditions (Nm)

C_g : flow coefficient (see table below), natural gas with relative density $d=0,6$ and absolute temperature 273K.

If density and temperature are different from normal conditions ($d=0,6$ and $T_e=273$ K), multiply the result with correction factor K:

$$K = d \times (T_e + 273) / (0,6 \times 273)$$

Flow coefficient :

DN	25	40	50	80	100
C_g	620	1140	1900	4700	7100

Flow coefficient :

Example:

P = 5 bar(g)

Q = 500 Nm³/h

T_e = 20 °C (293 K)

DN = 50

d = 0,7

Calculation:

1) $\Delta P = (500/1900)^2 \times 1 / 6 = 0,011$ bar

2) $K = 0,7 \times (20 + 273) / 0,6 \times 273 = 1,25$

3) $\Delta P \times K = 0,011 \times 1,25 = 0,014$ bar

$\Delta P = ?$

Result: $\Delta P = 0,014$ bar

Dresser Utility Solutions GmbH

Hardeckstr. 2

76185 Karlsruhe

T: +49 (0)721 / 5981 - 100

info.karlsruhe@dresserutility.com



www.dresserutility.com

© 2023 Dresser Utility Solutions GmbH – All rights reserved. Dresser Utility Solutions reserves the right to make changes in specifications and features shown herein, or discontinue the product described at any time without notice or obligation. Contact your Dresser Utility Solutions representative for the most current information. The Dresser Logo and all Trademarks containing the term "Dresser" are the property of Dresser, LLC, a subsidiary of Baker Hughes. Actaris™ is a trademark owned by Itron, Inc. and used under license.