

CL838 Series



Twin Parallel Flow Service Regulators

The CL838 series regulators is a single valve body regulator with large twin diaphragm cases that are pilot loaded to insure a high degree of accuracy during fixed factor measurement. This regulator is ideal for commercial and industrial service regulator applications when installed in compliance with D.O.T. regulations. The CL838 requires an inlet pressure of only 0.5 PSIG above outlet pressure.

Benefits

- » Parallel regulation with regulator and monitor in continuous operation
- » Combined unit saves space and eliminates extra piping
- » Designed to meet D.O.T. service regulator safety standards
- » Accurate, reliable, versatile

Models

- » CL838-1 – Maximum inlet pressure is 150 PSIG; outlet pressure range 6" W.C. to 5 PSIG; orifice size 3/8" to 1 3/8"
- » CL838-2 – Maximum inlet pressure is 150 PSIG; outlet pressure range from 1 PSIG to 30 PSIG; orifice sizes available from 3/8" to 1 3/8"
- » CL838D-1 – (Downstream) Maximum inlet pressure 150 PSIG; outlet pressure range 6" W.C. to 5 PSIG with closed throat and equipped for downstream control tap. This unit is used when it is desirable to control the regulator from a downstream sensing point other than the regulator valve body outlet side
- » CL838D-2 – Maximum inlet pressure is 150 PSIG. Outlet pressure range is from 1 PSIG to 30 PSIG. All other facets of the CL838D-2 are the same as the CL838D-1 regulator. Orifice sizes available are 3/8" through 1 3/8"
- » CL838M-1 – Regulator for monitor installation with closed throat and o-ring seal on the valve stem at the throat to assure positive downstream control when installed ahead of the operating regulator. This unit provides an operating safety device which assumes control over the operating regulator when failure is sensed by the monitor control line. The monitor regulator is set to take over control from the operating regulator with only a slight increase in outlet pressure. Orifice sizes 3/8" through 1 3/8" and outlet pressure range from 6" W.C. to 5 PSIG. And inlet pressures of 150 PSIG max
- » CL838M-2 – Regulator for monitor installations. All facets of this regulator are the same as the CL838M-1 except the range of outlet pressures which are from 1 PSIG to 30 PSIG
- » CL838IM – is a single valve body regulator with large (12 1/16" dia.) twin diaphragm cases pilot loaded to insure a high degree of accuracy during fixed factor measurement. The internal monitor features the safety advantage of a second gas tight backup seat if the normal orifices' face and valve seats fail to contain the outlet pressure at the adjusted outlet pressure level. It also controls the gas flow between the failed open flow and no flow conditions, thus creating secondary regulation
- » CL838IM-1 – has a maximum inlet pressure of 125 PSIG and an outlet pressure range from 6 inches of water column to 5 PSIG. Orifice sizes are available from 3/8" to 1"
- » CL838IM-2 – has a maximum inlet pressure of 125 PSIG and an outlet pressure range from 1 PSIG to 30 PSIG.

SHIPPING WEIGHT

One regulator per box

Size	Box weight
2" x 2" NPT	88 lbs.
2" x 2" Flanged	98 lbs.
2" x 3" Flanged	115 lbs.
2" x 4" Flanged	125 lbs.

CL838 DIMENSIONS

Valve body FF	A	B	C	D	E	F	G	H
Screwed, 9"	9-5/8	13	2-3/16	37-3/4	18-7/8	12-3/4	7-3/8 (max.)	25
Flanged, 10"								

PILOT DIMENSIONS

Pilot	X	Y
1	6-1/2	13
2	6-3/4	13-1/2

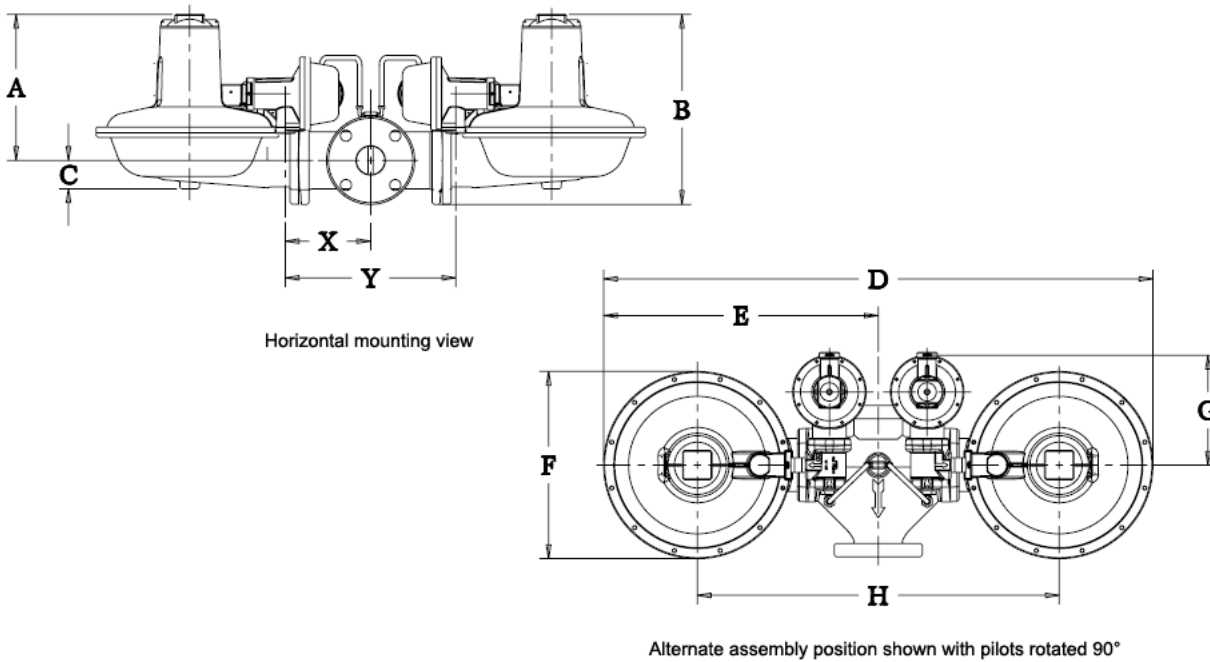

OPERATIONAL SCHEMATIC

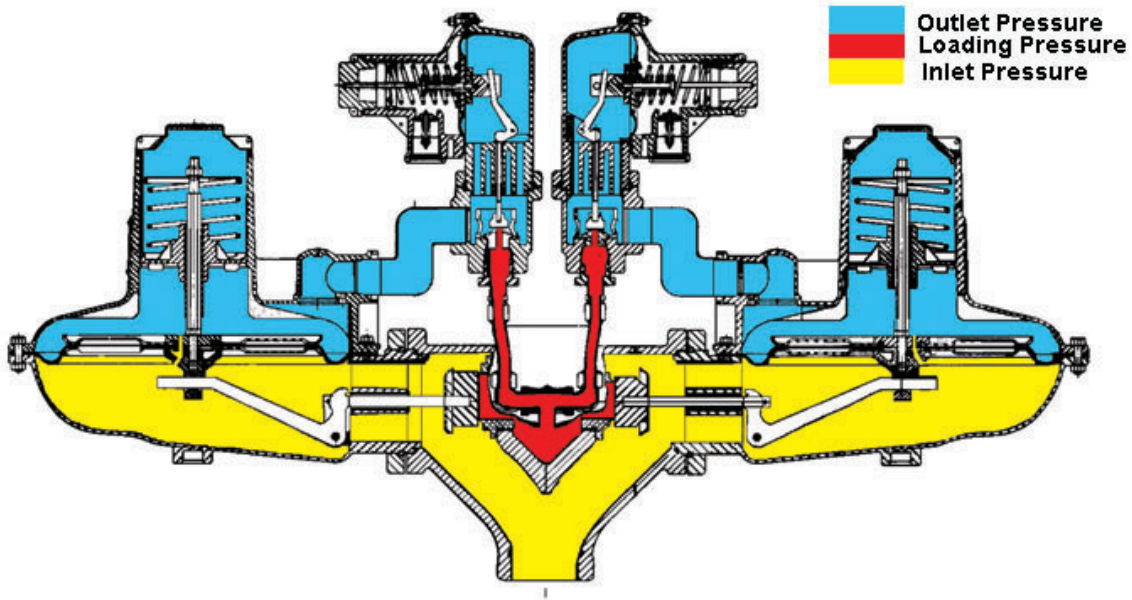

Note Valve shown closed position.

CLOSING SPRING DATA

Main Regulator Closing Spring Data							
Closing Spring Color	3/8"	1/2"	5/8"	3/4"	1"	1-1/4"	1-3/8"
Maximum Differential Pressure Across Orifice PSIG*							
Orange	75	70	53	27	13	9	6
Brown	250	140	90	46	34	21	15
Black	--	250	230	150	85	54	45

*The maximum recommended pressure differential and closing spring are based on 2:1 safety factor.

Note The maximum emergency pressure differential is 75% of two times the values shown in the above table. Maximum differential pressure equals maximum inlet pressure minus outlet pressure (set point).

PILOT SPRING DATA, SPRING COLOR OUTLET PRESSURE RANGE*

CL-838 - 11			
Closing spring			
Pilot loading spring	Orange	Brown	Black
Green/white	5.6 - 8.1" w.c.	-	-
Blue/white	8.2 - 16.6" w.c.	5.3 - 12.8" w.c.	-
Dark green	13.3 - 18.2" w.c.	8.6 - 14.8" w.c.	6.6 - 7.0" w.c.
Silver/white	0.75 - 1.5 PSIG	0.5-1.35 PSIG	9.3 - 29.0" w.c.
Yellow/white	1.8 - 2.7 PSIG	1.7 - 2.5 PSIG	1.5 - 2.2 PSIG
Red/white	2.6 - 4.6 PSIG	3.3 - 5.0 PSIG	3.2 - 5.0 PSIG
White	3.8 - 5.0 PSIG	3.3 - 5.0 PSIG	3.2 - 5.0 PSIG
CL838 - 22			
Brown	0.75 - 2.7 PSIG	0.75 - 2.25 PSIG	0.75 - 1.8 PSIG
Green	1.5 - 9.5 PSIG	1.5 - 9.5 PSIG	1.5 - 8.0 PSIG
Black	5.0 - 14.8 PSIG	5.0 - 14.6 PSIG	5.0 - 14.3 PSIG
Blue	9.0 - 29 PSIG	9.0 - 29 PSIG	9.0 - 29 PSIG
Silver	25 - 30 PSIG	25 - 30 PSIG	25 - 30 PSIG

Notes

*Spring ranges are approximate and may vary by application.

1 The maximum recommended outlet pressure from a CL-838-1 and CL-838-1IM is 5 PSIG.

2 The maximum recommended outlet pressure from a CL-838-2 and CL-838-2IM is 30 PSIG.

Springs are not interchangeable between the CL838 and CL838IM.

CL838 INTERNAL MONITOR CLOSING SPRING DATA

IM Regulator Closing Spring Data					
Closing Spring Color	3/8"	1/2"	5/8"	3/4"	1"
Maximum Differential Pressure Across Orifice PSIG*					
Green	250	140	95	50	37
Black	--	250	230	150	109

*The maximum recommended pressure differential and closing spring are based on 2:1 safety factor.

Note The maximum emergency pressure differential is 75% of two times the values shown in the above table. **For more information about internal monitor operation, see CL838 Internal Monitors.

Maximum differential pressure equals maximum inlet pressure minus outlet pressure (set point).

PILOT SPRING DATA, SPRING COLOR OUTLET PRESSURE RANGE*

CL-838-1 IM		
Closing Spring		
Pilot Spring Color	Green	Black
Blue/white	4.5 - 10.0" w.c.	-
Dark green	11.0 - 14.3" w.c.	4.0 - 6.2" w.c.
Silver/white	0.5 - 1.2 PSIG	6.0 - 21.4" w.c.
Yellow/white	1.6 - 2.3 PSIG	1.3 - 3.4 PSIG
Red/white	2.1 - 3.8 PSIG	1.9 - 3.4 PSIG
White	3.0 - 5.0 PSIG	3.0 - 5.0 PSIG
CL-838-2-IM		
Brown	0.75 - 2.1 PSIG	0.75 - 1.8 PSIG
Green	1.5 - 10.0 PSIG	1.5 - 9.2 PSIG
Black	5.0 - 12.9 PSIG	5.0 - 12.0 PSIG
Blue	9.0 - 30.0 PSIG	9.0 - 30.0 PSIG

Notes

*Spring Ranges are approximate and may vary by application.

1 The maximum recommended outlet pressure from a CL-838-1 and CL-838-1IM is 5 PSIG.

2 The maximum recommended outlet pressure from a CL-838-2 CL-838-2IM is 30 PSIG. Springs are not interchangeable between CL838 and CL838 IM.

ORIFICE DATA, WIDE OPEN FLOW COEFFICIENTS AND MAXIMUM PRESSURE DATA

Orifice Size (inches)	K-factors	Maximum Operatin Modg Inlet Pressure R els		Max Emergency Inlet Pressure	Max. Emergency Outlet Pressure (containment)	
		In w.c. delivery	PSIG delivery	All Outlet		
		Pressure PSIG	Pressure PSIG	Inlet Pressure PSIG	In w.c. delivery	PSIG delivery
3/8	510	150	150	150% of the maximum pressure of the closing spring differential	40	40
3/8 IM	510	150	150			
1/2	780	150	150			
1/2 IM	780	150	150			
5/8	990	125	125			
5/8 IM	990	60	60			
3/4	1350	125	125			
3/4 IM	1350	60	60			
1	1850	100	100			
1 IM	1850	30	30			
1-1/4	2280	60	75			
1-3/8	2510	60	75			

OPERATING TEMPERATURE

- » • -20°F to 150°F
- » • Silicone valve seats available for applications below -20°F

ADDITIONAL SPECIFICATIONS

Available pilot vent sizes	3/4"
Loading ring position	For outlet pressure > 1 PSIG: 0° For outlet pressure < 1 PSIG: 25°
Other available options	Seal wire to indicate unapproved tampering
	1/4" pipe plug tap on upstream side of valve body
	Pilot supply line filter (contact ROOTS Regulators, Owenton KY for specifications)
	Stainless steel supply line fittings

CONSTRUCTION

ROOTS Regulators takes pride in delivering American made products with the utmost concern for safety, quality, and customer satisfaction.

Construction material	
Valve bodies	High tensile strength cast iron (ASTM A-126, Class A)
Orifices	Brass
Valve seats	Buna-N
Valve stems	Nylon
Lever pins	Stainless steel (type 303)
Levers	Zinc and dichromate plated steel (AISI C1010)
Upper diaphragm plates	Zinc and dichromate plated steel (14-gauge steel)
Lower diaphragm plates	Die cast aluminum (ASTM B-85 Alloy SC84A)
Diaphragms	Buna-N reinforcing fiber
Vent valves/seats	Neoprene
Vent screen	Stainless steel (16 mesh)
Adjustment ferrules	Aluminum
Seal caps	ABS plastic
Diaphragm cases	Die cast aluminum (ASTM B85 - Alloy SC84A)
Valve stem inserts	Aluminum

VALVE BODY SIZES

Inlet	Outlet	SCR	Flanged
2"	2"	X	X
2"	3"		X
2"	4"		x

X indicates the valve body is available in that configuration.

CORRECTION FACTORS FOR NON-NATURAL GAS APPLICATIONS

The CL838 may be used to control gases other than natural gas. To determine the capacity for gases other than natural gas, multiply the values within the capacity tables by a correction factor. The table below lists the correction factors for some of the more common gases.

Gas Type	Specific Gravity	Correction Factor (CF)
Air	1.00	0.77
Butane	2.01	0.55
Carbon Dioxide (Dry)	1.52	0.63
Carbon Monoxide (Dry)	0.97	0.79
Natural Gas	0.60	1.00
Nitrogen	0.97	0.79
Propane	1.53	0.63
Propane-Air-Mix	1.20	0.71

To calculate the correction factor for gases not listed in the table above, use the gases' specific gravity and insert it in the formula listed below:

$$\text{Correction Factor (CF)} = \sqrt{\frac{SG_1}{SG_2}}$$

Where: SG1 = Specific gravity of the gas in which the capacity is published.

SG2 = Specific gravity of the gas to be controlled.

Wide Open Flow Calculations

For wide-open orifice flow calculations use the following equations:

For $\frac{P_1}{P_2} < 1.89$ use: $Q = K\sqrt{P_2(P_1 - P_2)}$

For $\frac{P_1}{P_2} > 1.89$ use: $Q = \frac{KP_1}{2}$

Where: P1 = Absolute Inlet Pressure (PSIA)

P2 = Absolute Outlet Pressure (PSIA)

Q = Flow Rate (SCFH)

K = Orifice Coefficient (SCFH/PSI)

CL838 2 X 2 CAPACITY TABLE

Capacities based on 0.6 Sp. Gr. gas at 14.7 PSIA and 60°F.

Typical Capacity Info.	
Manufacturer	ROOTS Regulators
Type and model	CL838
Regulator	
Inlet size	2-inch flanged 2-inch SCR
Outlet size	2-inch flanged 2-inch SCR
Spring color	Varies

Orifice Size		3/8	1/2	5/8	3/4	1	1-1/4	1-3/8
Inlet Pressure PSIG	Outlet Pressure (PSIG)	Orifice constant factor K						
		510	780	990	1350	1850	2280	2510
2	7" w.c.	2.55	3.55	4.55	6.0	8.65	10.0	11.7
	11" w.c.	2.55	3.5	4.5	5.95	8.35	1.7	11.3
	1	2.1	2.95	3.75	4.8	6.9	8.05	9.3
	1.5	1.65	2.4	3.35	4.3	5.6	7.0	7.95
3	7" w.c.	3.15	4.2	5.8	7.5	10.6	12.7	14.4
	11" w.c.	2.95	4.2	5.8	7.35	10.4	12.5	14.1
	1	2.8	3.9	5.2	6.65	9.45	11.2	12.7
	2	2.15	3.0	4.1	5.15	7.1	8.55	9.7
5	7" w.c.	4.05	5.65	7.65	9.75	13.9	17.0	18.8
	11" w.c.	4.05	5.65	7.55	9.65	13.7	16.8	18.6
	1	3.8	5.65	7.2	9.2	13.1	16.0	17.7
	2	3.45	5.25	6.5	8.3	11.8	14.4	15.9
	3	3.1	4.15	5.55	7.1	10.0	12.3	13.6
10	7" w.c.	5.8	8.45	10.8	13.9	19.7	24.2	26.7
	11" w.c.	5.8	8.45	10.8	13.8	19.7	24.1	26.6
	1	5.7	8.35	10.7	13.7	19.4	23.8	26.3
	2	5.55	8.1	10.4	13.3	18.9	23.2	25.6
	5	4.8	7.0	9.05	11.5	16.4	20.1	22.2
	8	3.35	4.95	6.35	8.1	11.5	14.1	15.6
15	1 or less	7.05	10.3	13.3	17.0	24.2	29.7	32.8
	2	7.0	10.3	13.2	16.9	24.0	29.5	32.6
	5	6.75	9.85	12.6	16.2	23.0	28.2	31.1
	8	6.05	8.9	11.4	14.6	20.8	25.4	28.1
	10	5.35	7.9	10.1	13.0	18.4	22.6	25.0
	13	3.75	5.5	7.1	9.05	12.9	15.8	17.4
20	3.5 or less	8.2	12.1	15.6	19.9	28.3	34.7	38.3
	5	8.15	12.0	15.4	19.7	28.1	34.4	38.0
	10	7.5	11.0	14.2	18.2	25.8	31.6	34.9
	15	5.9	8.7	11.2	14.3	20.3	24.9	27.5
	18	4.1	6.05	7.8	9.95	14.1	17.3	19.1
30	9 or less	10.6	15.6	20.1	25.7	36.4	44.7	49.3
	10	10.5	15.5	20.0	25.5	36.3	44.5	49.1
	15	10.0	14.8	19.0	24.3	34.6	42.4	46.8
	20	8.95	13.1	16.9	21.6	30.7	37.7	41.6
40	14 or less	12.9	19.1	24.6	31.4	44.6	54.7	60.4
	15	12.9	19.0	24.5	31.3	44.5	54.5	60.2
	20	12.5	18.5	23.7	30.4	43.1	52.8	58.4
	30	10.2	15.0	19.3	24.7	35.4	43.0	47.5

Notes
 K values are wide open for each orifice size.
 Loading Ring set at 0° for PSIG outlet pressures. Loading ring set at 25° for inches w.c. outlet pressures. Exact settings may vary with individual pressure and load condition applications.
 Set point at each outlet pressure was 500 cfh.

CL838 2 X 2 CAPACITY TABLE (CONTINUED)

Capacities based on 0.6 Sp. Gr. gas at 14.7 PSIA and 60°F.

Typical Capacity Info.	
Manufacturer	ROOTS Regulators
Type and model	CL838
Regulator	
Inlet size	2-inch flanged 2-inch SCR
Outlet size	2-inch flanged 2-inch SCR
Spring color	Varies

Orifice Size		3/8	1/2	5/8	3/4	1	1-1/4	1-3/8
Inlet Pressure PSIG	Outlet Pressure PSIG	Orifice constant factor K						
		510	780	990	1350	1850	2280	2510
50	19.5 or less	15.3	22.6	29.1	37.2	52.8	64.7	71.4
	20	15.3	22.6	29.0	37.1	52.7	64.5	71.3
	30	14.2	21.0	27.0	34.5	49.1	60.1	66.4
60	24.5 or less	17.7	26.1	33.6	42.9	60.9	74.7	82.5
	25	17.7	26.1	33.5	42.8	60.9	74.5	82.4
	30	17.4	25.6	33.0	42.2	59.9	73.4	81.1
75	30 or less	21.3	31.1	40.3	51.5	73.2	89.7	99.0
100	30 or less	27.2	40.1	51.6	65.9	93.6		
125	30 or less	33.1	48.8	62.8	80.3			

Notes

K values are wide open for each orifice size.

Figures below heavy line may show differentials above allowable limits. Check closing spring tables to confirm.

Loading Ring set at 0° for PSIG outlet pressures. Loading ring set at 25° for inches w.c. outlet pressures. Exact settings may vary with individual pressure and load condition applications.

All capacities at 1% outlet pressure absolute pressure drop.

Set point at each outlet pressure was 500 cfh.

Maximum recommended inlet pressure (PSI to inches regulation) left of heavy black line.

████████ Do not operate orifice in shaded inlet pressure area.

CL838 CAPACITY TABLE 2 X 3

Capacities based on 0.6 Sp. Gr. gas @ 14.7 PSIA and 60°F.

Typical Capacity Info.	
Manufacturer	ROOTS Regulators
Type and model	CL838
Regulator	
Inlet size	2-inch flanged
Outlet size	3-inch flanged
Spring color	Varies

Orifice size		3/8"	1/2"	5/8"	3/4"	1"	1-1/4"	1-3/8"
Inlet Pressure PSIG	Inlet Pressure PSIG	Orifice constant factor K						
		550	930	1290	1610	2075	2515	2710
2	7" w.c.	2.7	4.3	5.6	7.45	9.9	12.4	13.5
	11" w.c.	2.6	4.15	5.4	7.2	9.6	12.0	13.0
	1	2.1	3.45	4.5	5.95	7.95	9.95	10.8
	1.5	1.75	2.65	3.65	4.7	6.1	7.65	8.3
3	7" w.c.	3.4	5.6	7.1	9.2	12.4	15.3	16.6
	11" w.c.	3.35	5.5	6.95	9.0	12.1	15.0	16.3
	1	3.0	4.9	6.3	8.15	11.0	13.6	14.7
	2	2.25	3.6	4.75	6.15	8.3	10.3	11.1
5	7" w.c.	4.5	7.3	9.35	12.3	16.3	20.2	22.3
	11" w.c.	4.45	7.2	9.25	12.2	16.2	20.0	22.0
	1	4.25	6.85	8.8	11.6	15.4	19.0	21.0
	2	3.7	6.1	7.95	10.4	13.9	17.1	18.9
	3	3.2	5.15	6.75	8.95	11.8	14.6	16.1
10	7" w.c.	6.45	10.2	13.9	18.1	23.6	28.7	31.7
	11" w.c.	6.45	10.2	13.8	18.1	23.5	27.6	31.6
	1	6.35	10.1	13.7	17.8	23.2	28.3	31.2
	2	6.2	9.85	13.3	17.4	22.6	27.5	30.4
	5	5.2	8.55	11.5	15.1	19.6	23.9	26.3
	8	3.6	6.0	8.1	10.6	13.7	16.8	18.5
15	1 or less	7.95	13.3	17.8	23.0	29.3	35.2	38.9
	2	7.9	13.2	17.7	22.8	29.1	35.0	38.6
	5	7.5		16.9	21.8	27.8	33.4	36.9
	8	6.75	11.4	15.2	19.7	25.1	30.2	33.3
	10	5.95	10.1	13.5	17.5	22.3	26.9	29.6
	13	4.0	7.1	9.45	12.2	15.6	18.7	20.7
20	3.5 or less	9.4	15.6	21.1	27.3	34.7	41.2	45.4
	5	9.3	15.4	21.0	27.1	34.4	40.8	45.1
	10	8.5	14.2	19.3	24.9	31.6	37.5	41.4
	15	6.6	11.2	15.2	19.6	24.9	29.6	32.6
	18	4.4	7.8	10.5	13.6	17.3	20.6	22.7
30	9 or less	12.2	20.1	27.4	35.2	44.7	53.4	58.5
	10	12.1	20.0	27.3	35.0	44.5	53.1	58.2
	15	11.5	19.0	26.0	33.4	42.4	50.6	55.5
	20	10.2	16.9	23.1	29.6	37.7	45.0	49.3
	25	7.7	13.1	17.9	22.9	29.1	34.8	38.1
40	14 or less	14.9	24.6	33.9	43.0	54.7	65.3	71.6
	15	14.9	24.5	33.8	42.9	54.5	65.1	71.4
	20	14.4	23.7	32.7	41.6	52.8	63.1	69.2
	30	11.5	19.3	26.6	33.8	43.0	51.3	56.3

Notes

Set point at each outlet pressure was 500 cfh.

Loading ring set at 0° for PSIG outlet pressures. Loading ring set at 25° for inches w.c. outlet pressures. Exact settings may vary with individual applications of pressures and load conditions.

K factors are wide open for each orifice size.

CL838 CAPACITY TABLE 2 X 3 (CONTINUED)

Typical Capacity Info.

Manufacturer	ROOTS Regulators
Type and model	CL838
Regulator	
Inlet size	2-inch flanged
Outlet size	3-inch flanged
Spring color	Varies

Orifice size		3/8"	1/2"	5/8"	3/4"	1"	1-1/4"	1-3/8"
Inlet Pressure PSIG	Inlet Pressure PSIG	Orifice constant factor K						
		550	930	1290	1610	2075	2515	2710
50	19.5 or less	17.7	29.1	40.1	50.9	64.7	77.3	84.7
	20	17.6	29.0	40.0	50.8	64.5	77.1	84.5
	30	16.3	27.0	37.3	47.3	60.1	71.8	78.8
60	24.5 or less	20.4	33.6	46.3	58.8	74.7	89.2	97.8
	25	20.3	33.5	46.2	58.7	74.5	89.1	97.7
	30	20.0	33.0	45.5	57.8	73.4	87.7	96.1
75	30 or less	24.5	40.3	55.6	70.6	90.0	107.1	117.5
100	30 or less	31.3	51.6	71.1	90.2	115.0		
125	30 or less	38.1	62.8	86.6	109.0			

Notes

Maximum recommended inlet pressure (PSI to inches regulation) left of heavy black line.

Set point at each outlet pressure was 500 cfh.

Loading ring set at 0° for PSIG outlet pressures. Loading ring set at 25° for inches w.c. outlet pressures. Exact settings may vary with individual applications of pressures and load conditions.

K factors are wide open for each orifice size.

████████ Do not operate orifice in shaded inlet pressure area.

CL838 CAPACITY TABLE 2 X 4

Capacities based on 0.6 Sp. Gr. gas @ 14.7 PSIA and 60°F.

Typical Capacity Info.

Manufacturer	ROOTS Regulators
Type and model	CL838
Regulator	
Inlet size	2-inch flanged
Outlet size	4-inch flanged
Spring color	Varies

Orifice size		3/8"	1/2"	5/8"	3/4"	1"	1-1/4"	1-3/8"
Inlet Pressure PSIG	Inlet Pressure PSIG	Orifice constant factor K						
		565	950	1350	1710	2190	2625	3050
2	7" w.c.	2.85	4.6	6.25	8.2	11.0	13.3	14.3
	11" w.c.	2.8	4.55	6.25	7.9	10.7	12.9	13.8
	1	2.35	3.7	5.1	6.55	8.8	10.6	11.4
	1.5	1.85	3.1	4.2	5.3	7.0	8.2	8.8
3	7" w.c.	3.55	5.75	7.95	10.1	13.6	16.3	19.7
	11" w.c.	3.5	5.7	7.8	9.9	13.4	16.0	19.4
	1	3.25	5.05	7.05	8.9	12.1	14.4	18.5
	2	2.3	4.0	5.35	7.05	9.15	10.9	13.1
5	7" w.c.	4.65	7.7	10.2	13.1	17.7	21.6	25.7
	11" w.c.	4.65	7.6	10.1	13.0	17.6	21.5	25.5
	1	4.35	7.15	9.65	12.4	16.6	20.5	23.4
	2	3.95	6.55	8.7	11.2	15.0	17.9	19.9
10	3	3.35	5.55	7.45	9.55	12.3	15.6	17.5
	7" w.c.	6.7	10.8	15.4	20.4	25.9	30.2	35.8
	11" w.c.	6.7	10.8	15.4	20.4	25.9	30.1	35.5
	1	6.6	10.6	15.1	20.1	25.5	29.7	35.0
15	2	6.4	10.3	14.7	19.5	24.8	28.9	34.1
	5	5.4	8.95	12.8	16.9	21.5	25.0	29.5
	8	3.8	6.3	9.0	11.9	15.1	17.6	20.7
	1 or less	8.3	13.8	19.0	24.6	31.1	37.8	43.0
	2	8.25	13.7	18.8	24.4	30.8	37.5	42.7
20	5	7.85	13.0	17.9	23.3	30.1	35.8	40.8
	8	7.1	11.8	16.2	21.0	27.2	32.4	30.9
	10	6.3	10.5	14.4	18.7	24.2	28.8	32.8
	13	4.4	7.3	10.0	13.0	16.9	20.1	22.9
	3.5 or less	9.65	16.0	22.5	28.7	37.3	44.2	50.3
30	5	9.6	15.8	22.3	28.4	36.8	43.8	49.9
	10	8.8	14.5	20.5	26.1	33.8	40.3	45.9
	9 or less	12.4	20.6	29.0	36.9	48.0	56.9	64.8
	10	12.4	20.5	28.8	36.8	47.7	56.6	64.5
	15	11.8	19.8	27.5	35.0	45.4	53.9	61.5
40	20	10.5	17.3	24.4	31.2	40.4	48.0	54.6
	25	8.1	13.4	18.8	24.1	31.2	37.0	42.2
	14 or less	15.2	25.7	35.5	45.2	58.8	70.4	79.3
	15	15.2	25.6	35.4	45.1	58.5	70.1	79.0
40	20	14.7	24.5	34.3	43.7	56.7	68.0	76.6
	30	12.0	19.9	27.9	35.5	46.1	55.3	62.3

Notes

Set point at each outlet pressure was 500 cfh.

Loading ring set at 0° for PSIG outlet pressures. Loading ring set at 25° for inches w.c. outlet pressures. Exact settings may vary with individual applications of pressures and load conditions.

All capacities at 1% outlet pressure absolute pressure drop.

K factors are wide open for each orifice size.

CL838 CAPACITY TABLE 2 X 4 (CONTINUED)

Capacities based on 0.6 Sp. Gr. gas @ 14.7 PSIA and 60°F.

Typical Capacity Info.

Manufacturer	ROOTS Regulators
Type and model	CL838
Regulator	
Inlet size	2-inch flanged
Outlet size	4-inch flanged
Spring color	Varies

Orifice size		3/8"	1/2"	5/8"	3/4"	1"	1-1/4"	1-3/8"
Inlet Pressure PSIG	Inlet Pressure PSIG	Orifice constant factor K						
		565	950	1350	1710	2190	2625	3050
50	19.5 or less	18.0	30.4	42.0	53.5	69.5	82.4	93.8
	20	18.0	30.3	41.9	53.4	69.2	82.2	93.6
	30	16.8	27.9	39.0	49.7	64.5	76.6	87.2
60	24.5 or less	20.8	35.1	48.5	61.8	80.9	95.2	108.3
	25	20.8	34.9	48.4	61.7	80.0	95.0	108.1
	30	20.5	34.1	47.6	60.7	78.7	93.4	106.4
75	30 or less	25.0	42.1	58.3	74.2	96.4	114.3	130.0
100	30 or less	32.0	53.9	74.5	94.9	123.3		
125	30 or less	39.0	65.6	90.8	115.6			

Notes

Maximum recommended inlet pressure (PSI to inches regulation) left of heavy black line.

Set point at each outlet pressure was 500 cfh.

Loading ring set at 0° for PSIG outlet pressures. Loading ring set at 25° for inches w.c. outlet pressures. Exact settings may vary with individual applications of pressures and load conditions.

All capacities at 1% outlet pressure absolute pressure drop.

K factors are wide open for each orifice size.

████████ Do not operate orifice in shaded inlet pressure area.

MONITOR SPECIFICATIONS

CL-838M MONITOR SPECIFICATIONS 2" X 2"

Orifice Size (inches)	Inlet Pressure PSIG	Capacity, SCFH								
		Drop in pressure across orifice, PSIG								
		0.1	0.2	0.3	0.4	0.5	1.0	2.0	3.0	5.0
1-3/8 K = 2510	1	3100	4400	5350	6200	6900				
	2	3200	4550	5550	6400	7100	9900			
	3	3300	4650	5700	6600	7350	10200	14000		
	5	3500	4950	6050	6950	7750	10800	14900	17700	
	8	3750	5300	6500	7450	8350	11600	16100	19200	23600
	10	3900	5550	6750	7800	8700	12200	16900	20200	24900
	15	4300	6050	7450	8550	9550	13400	18600	22400	27800
	25	4950	7050	8600	9950	11100	15600	21700	26300	33000
	35	5550	7850	9650	11100	12400	17500	24500	29700	37500
	50	6350	9000	11000	12700	14200	20000	28100	34100	43300
	75	7500	10600	12900	15000	16700	23600	33200	40400	51600
1-1/4 K = 2280	1	2800	4000	4900	5600	6250				
	2	2900	4100	5050	5800	6450	9000			
	3	3000	4250	5200	5950	6650	9300	12700		
	5	3150	4500	5500	6300	7050	9850	13500	16100	
	8	3400	4800	5900	6800	7550	10600	14600	17500	21400
	10	3550	5000	6150	7100	7900	11000	15300	18300	22600
	15	3900	5500	6750	7800	8700	12200	16900	20400	25300
	25	4500	6400	7800	9000	10000	14100	19700	23900	30000
	35	5050	7150	8750	10100	11300	15900	22200	26900	34000
	50	5750	8150	10000	11500	12900	18100	25500	31000	39300
	75	6800	9600	11800	13600	15200	21400	30100	36700	46900
1 K = 1850	1	2300	3250	3950	4550	5100				
	2	2350	3350	4100	4700	5250	7300			
	3	2450	3450	4200	4850	5400	7550	10300		
	5	2550	3650	4450	5100	5700	8000	11000	13000	
	8	2750	3900	4750	5500	6150	8600	11900	14200	17400
	10	2900	4050	5000	5750	6400	9000	12400	14900	18300
	15	3150	4450	5450	6300	7050	9900	13700	16500	20500
	25	3650	5150	6350	7300	8150	11500	16000	19400	24300
	35	4100	5800	7100	8200	9150	12900	18000	21800	27600
	50	4700	6600	8100	9350	10400	14700	20700	25100	31900
	75	5500	7500	9550	11000	12300	17400	24500	29800	38000
100	6250	8850	10800	12500	13900	19700	27700	33800	43300	

CL-838M MONITOR SPECIFICATIONS 2" X 3"

Orifice Size (inches)	Inlet Pressure PSIG	Capacity, SCFH								
		Drop in pressure across orifice, PSIG								
		0.1	0.2	0.3	0.4	0.5	1.0	2.0	3.0	5.0
1-3/8 K = 2710	1	3350	4750	5800	6700	7450				
	2	3450	4900	6000	6900	7700	10700			
	3	3550	5050	6150	7100	7900	11000	15100		
	5	3750	5350	6500	7500	8350	11700	16100	19100	
	8	4050	5700	7000	8050	9000	12600	17400	20800	25400
	10	4250	5950	7300	8400	9400	13100	18200	21800	26800
	15	4650	6550	8000	9250	10300	14500	20100	24200	30100
	25	5350	7600	9300	10700	11900	16800	23500	28400	35600
	35	6000	8500	10400	12000	13400	18900	26400	32000	40500
	50	6850	9700	11900	13700	15300	21600	30300	36800	46800
	75	8100	11400	14000	16100	18000	25500	35800	43700	55700
1-1/4 K = 2515	1	3100	4400	5400	6200	6900				
	2	3200	4550	5550	6400	7150	9950			
	3	3300	4700	5700	6600	7350	10200	14000		
	5	3500	4950	6050	6950	7750	10800	14900	17800	
	8	3750	5300	6500	7500	8350	11700	16100	19300	23600
	10	3900	5550	6800	7800	8700	12200	16900	20200	24900
	15	4300	6100	7450	8600	9600	13400	18700	22500	27900
	25	5000	7050	8600	9950	11100	15600	21800	26300	33100
	35	5600	7900	9650	11100	12400	17500	24600	29700	37500
	50	6350	9000	11000	12700	14200	20000	28100	34200	43400
	75	7500	10600	13000	15000	16700	23600	33300	40500	51700
1 K = 2075	1	2550	3650	4450	5100	5700				
	2	2650	3750	4600	5250	5900	8200			
	3	2750	3850	4700	5450	6050	8450	11600		
	5	2900	4050	5000	5750	6400	8950	12300	14600	
	8	3150	4400	5350	6150	6900	9650	13300	15900	19500
	10	3250	4550	5600	6450	7200	10100	13900	16700	20500
	15	3550	5000	6150	7100	7900	11100	15400	18500	23000
	25	4100	5800	7100	8200	9150	12900	18000	21700	27300
	35	4600	6500	7950	9200	10200	14400	20200	24500	31000
	50	5250	7450	9100	10500	11700	16500	23200	28200	35800
	75	6200	8750	10700	12400	13800	19500	27400	33400	42700
100	7000	9900	12100	14000	15600	23500	31100	37900	49500	

CL-838M MONITOR SPECIFICATIONS 2" X 4"

Orifice Size (inches)	Inlet Pressure PSIG	Capacity, SCFH									
		Drop in pressure across orifice, PSIG									
		0.1	0.2	0.3	0.4	0.5	1.0	2.0	3.0	5.0	
1-3/8 K = 3050	1	3800	5350	6550	7500	8400					
	2	3900	5500	6750	7750	8650	12000				
	3	4000	5700	6950	8000	8900	12400	17000			
	5	4250	6000	7350	8450	9450	13100	18100	21500		
	8	4550	6450	7900	9100	10100	14200	19600	23400	28600	
	10	4750	6750	8250	9500	10600	14800	20500	24600	30200	
	15	5200	7400	9050	10400	11600	16300	22700	27200	33800	
	25	6050	8550	10400	12000	13500	18900	26400	32000	40100	
	35	6750	9550	11700	13500	15100	21200	29700	36100	45500	
	50	7750	10900	13400	15400	17200	24300	34100	41400	52600	
	75	9100	12900	15700	18200	20300	28700	40300	49100	62700	
1-1/4 K = 2625	1	3250	4600	5600	6450	7200					
	2	3350	4750	5800	6700	7450	10400				
	3	3450	4900	5950	6900	7650	10700	14700			
	5	3650	5150	6300	7250	8100	11300	15600	18500		
	8	3900	5550	6800	7800	8700	12200	16800	20100	24600	
	10	4100	5800	7100	8150	9100	12700	17600	21100	26000	
	15	4500	6350	7750	8950	10000	14000	19500	23400	29100	
	25	5200	7350	9000	10400	11600	16300	22700	27500	34500	
	35	5800	8250	10100	11600	13000	18300	25600	31000	39200	
	50	6650	9400	11500	13300	14800	20900	29300	35700	45300	
	75	7850	11100	13500	15600	17500	24700	34700	42300	54000	
1 K = 2190	1	2700	3850	4700	5400	6000					
	2	2800	3950	4850	5550	6200	8650				
	3	2900	4050	5000	5750	6400	8900	12200			
	5	3050	4300	5250	6050	6750	9450	13000	15900		
	8	3250	4600	5650	6500	7250	10200	14000	16800	20600	
	10	3400	4800	5900	6800	7600	10600	14700	17600	21700	
	15	3750	5300	6500	7450	8350	11700	16300	19600	24300	
	25	4350	6150	7500	8650	9650	13600	19000	22900	28800	
	35	4850	6850	8400	9700	10800	15200	21300	25900	32700	
	50	5550	7850	9600	11100	12400	17400	24500	29700	37800	
	75	6550	9250	11300	13000	14600	20600	29000	35300	45000	
100	7400	10400	12800	14800	16500	23300	32800	40000	51200		

PRINCIPLE OF OPERATION

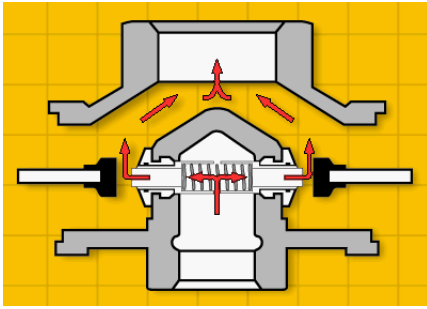

A. Normal regulation

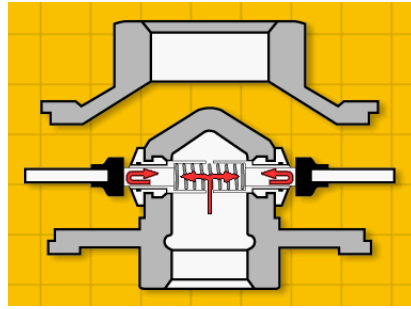

B. Normal lock-up

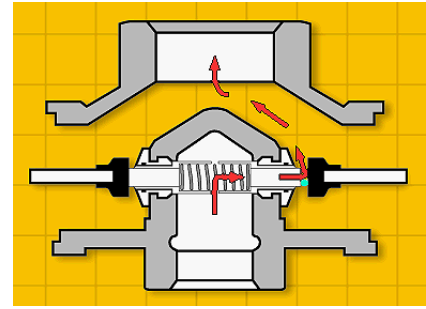

C. Dual monitor operation, internal foreign material failure

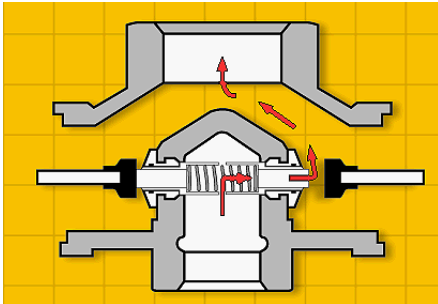

D. Single monitor operation, full internal diaphragm case failure

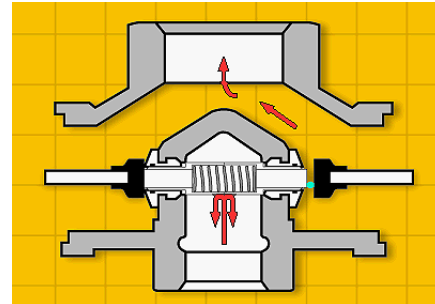

E. Total lock-up

PRINCIPLE OF OPERATION

A. Normal regulation. The internal monitor orifice operates like a standard one-piece orifice, performing normal regulation.

B. Normal lock-up. The regulator is free to lock-up in the usual manner. The O-ring seal prevents gas from leaking past the orifice exterior into the downstream or low pressure side of the valve body.

C. Dual monitor operation, internal foreign material failure. If the regulator fails to lock-up for any reason, the internal monitor orifice automatically goes into operation. Outlet pressure increases slightly, causing the valve seat to push against the inner or sliding part of the orifice gradually compressing the monitor spring and closing the secondary or monitor orifice on the inlet side of the sliding orifices. At this point, the CL838-IM functions as a monitor regulator. For example, assume a weld bead is caught between the orifice and the valve seat while the regulator is in high-flow operation. If the flow is reduced, the valve tries to close but can't due to the foreign matter. The outlet pressure increases approximately 2" w.c. above the original set point which starts to close the secondary monitor orifice. If the gas demand is decreased, the monitor orifice will partially close and become the new operating orifice. The new orifice will function as a monitor regulator and keep the outlet pressure approximately 3" above the set pressure on inches water column, or .8 PSIG when set for PSIG outlet. If the flow becomes further reduced to no-flow, then the sliding orifice (or orifices) close against the secondary rubber seat providing a complete no-gas flow with a total outlet pressure build-up of only 6" w.c. above the original set point.

D. Single monitor operation, one full internal diaphragm case failure. If the diaphragm case is damaged on one side of the piping such that the lever and valve seat cannot move to close against the orifice face, the outlet pressure builds (as described in C) on the good regulator and its sliding orifice moves to contact the non-movable failed orifice monitor seat. Closing or lock-up will be restricted according to flow demand. Since only one diaphragm is in operation, the outlet overpressure will be approximately 4" w.c. higher on single monitor operation than normal regulation set.

E. Total lock-up. If demand for gas downstream of regulator is zero, the sliding orifice (or orifices) will close against the secondary rubber monitor seat and lock-up the gas flow completely.

CL838-IMRV Flow Chart		
	Inlet pressure (PSIG)	Flow SCFH
Vented gas flow, regulator seat failed, monitor seat closed	20	60
	40	90
	60	120
	75	150
	100	190
	125	230

CL838 INTERNAL MONITOR CHARACTERISTICS

Outlet Pressure Set Point	Pilot Spring	Closing Spring	No Flow Outlet Pressure Buildup
7.0" w.c.	Blue/white	Green	24" w.c.
11.0" w.c.	Dark green	Green	28" w.c.
1 PSIG	Silver/white	Green	1.6 PSIG
2 PSIG	Yellow/white	Green	2.6 PSIG
3 PSIG	Red/white	Green	3.7 PSIG
5 PSIG	White	Green	5.8 PSIG
CL-838-2 IM			
1 PSIG	Brown	Green	2.0 PSIG
2 PSIG	Green	Green	3.0 PSIG
3 PSIG	Green	Green	4.2 PSIG
5 PSIG	Green	Green	6.2 PSIG
8 PSIG	Green	Green	9.2 PSIG
10 PSIG	Black	Green	11.4 PSIG
15 PSIG	Blue	Green	16.6 PSIG
20 PSIG	Blue	Green	22.0 PSIG
25 PSIG	Blue	Green	28.0 PSIG
30 PSIG	Blue	Green	33.4 PSIG

CL838 IM CAPACITY TABLE 2 X 2 SCFH X 1000

Capacities based on 0.6 Sp. Gr. gas @ 14.7 PSIA and 60°F.

Typical Capacity Info.

Manufacturer	ROOTS Regulators
Type and model	CL838 IM
Regulator	
Inlet size	2-inch SCR 2-inch flanged
Outlet size	2-inch SCR 2-, 3-, 4-inch flanged
Spring color	Varies

Orifice Size		3/8"	1/2"	5/8"	3/4"	1"
Inlet Pressure PSIG	Outlet Pressure PSIG	Orifice constant factor K				
		510	630	910	1140	1360
2	7" w.c.	2.4	3.1	4.45	5.2	6.35
	11" w.c.	2.35	3.0	4.35	5.1	6.15
	1	1.9	2.45	3.55	4.1	5.05
	1.5	1.5	1.95	2.8	3.2	3.9
3	7" w.c.	2.95	3.8	5.55	6.5	7.85
	11" w.c.	2.9	3.75	5.4	6.4	7.65
	1	2.65	3.35	4.9	5.75	6.9
	2	2.0	2.55	3.7	4.4	5.25
5	7" w.c.	3.85	4.95	7.2	8.5	10.2
	11" w.c.	3.8	4.9	7.1	8.4	10.1
	1	3.65	4.7	6.8	8.0	9.6
	2	3.25	4.2	6.1	7.2	8.65
	3	2.8	3.65	5.2	6.1	7.4
10	7" w.c.	5.5	7.05	10.2	12.2	14.5
	11" w.c.	5.5	7.05	10.2	12.1	14.4
	1	5.4	6.95	10.1	12.0	14.3
	2	5.25	6.8	9.85	11.7	13.9
	5	4.55	5.85	8.5	10.1	12.0
	8	3.2	4.1	5.95	7.1	8.45
15	1 or less	6.95	8.8	12.7	14.9	17.7
	2	6.9	8.75	12.6	14.9	17.6
	5	6.6	8.35	12.1	14.2	16.8
	8	6.0	7.55	10.9	12.8	15.2
	10	5.3	6.7	9.7	11.4	13.5
	13	3.7	4.7	6.75	7.95	9.4
20	3.5 or less	8.15	10.4	15.1	17.6	20.9
	5	8.1	10.3	14.9	17.5	20.7
	10	7.45	9.45	13.7	16.1	19.0
	15	5.85	7.45	10.8	12.7	15.0
	18	4.05	5.2	7.55	8.85	10.4
30	9 or less	10.7	13.4	19.5	22.9	26.9
	10	10.6	13.3	19.4	22.8	26.8
	15	10.1	12.7	18.5	21.7	25.5
	20	9.05	11.3	16.4	19.3	22.7
	25	6.95	8.7	12.7	14.9	17.5

Notes

K values are wide open for each orifice size.

Maximum recommended inlet pressure (PSI to inches) left of heavy shaded area.

Loading Ring set at 0° for PSIG outlet pressures. Loading ring set at 25° for inches w.c. outlet pressures. Exact settings may vary with individual pressure and load condition applications.

All capacities at 1% outlet pressure absolute pressure drop.

Set point at each outlet pressure was 500 cfh.

 Do not operate orifice in shaded inlet pressure area.

CL838 IM CAPACITY TABLE 2 X 2 SCFH X 1000 (CONTINUED)

Capacities based on 0.6 Sp. Gr. gas at 14.7 PSIA and 60°F.

Typical Capacity Info.	
Manufacturer	ROOTS Regulators
Type and model	CL838 IM
Regulator	
Inlet size	2-inch SCR 2-inch flanged
Outlet size	2-inch SCR 2-, 3-, 4-inch flanged
Spring color	Varies

Orifice Size		3/8"	1/2"	5/8"	3/4"	1"
Inlet Pressure PSIG	Outlet Pressure PSIG	Orifice constant factor K				
		510	630	910	1140	1360
40	14 or less	13.4	16.6	24.0	28.0	[Shaded Area]
	15	13.3	16.6	24.0	27.9	
	20	12.9	16.1	23.2	27.0	
	30	10.5	13.1	18.9	22.0	
50	19.5 or less	15.8	19.7	28.4	33.1	
	20	15.8	19.6	28.4	33.0	
	30	14.7	18.3	26.4	30.8	
60	24.5 or less	18.3	22.7	32.8	38.3	
	25	18.3	22.7	32.8	38.2	
	30	17.9	22.3	32.3	37.6	
75	30 or less	22.0	27.3			
100	30 or less	28.1	34.9			
125	30 or less	34.2	42.6			

Notes

K values are wide open for each orifice size.

Maximum recommended inlet pressure (PSI to inches) left of heavy shaded area.

Loading Ring set at 0° for PSIG outlet pressures. Loading ring set at 25° for inches w.c. outlet pressures. Exact settings may vary with individual pressure and load condition applications.

All capacities at 1% outlet pressure absolute pressure drop.

Set point at each outlet pressure was 500 cfh.

[Shaded Area] Do not operate orifice in shaded inlet pressure area.

CL838 IM CAPACITY TABLE 2 X 3

Capacities based on 0.6 Sp. Gr. gas at 14.7 PSIA and 60°F.

Typical Capacity Info.

Manufacturer	ROOTS Regulators
Type and model	CL838 IM
Regulator	
Inlet size	2-inch SCR 2-inch flanged
Outlet size	2-inch SCR 2-, 3-, 4-inch flanged
Spring color	Varies

Orifice Size		3/8"	1/2"	5/8"	3/4"	1"
Inlet Pressure PSIG	Outlet Pressure PSIG	Orifice constant factor K				
		535	690	960	1175	1430
2	7" w.c.	2.55	3.2	4.6	5.8	6.85
	11" w.c.	2.45	3.2	4.5	5.75	6.6
	1	2.05	2.65	3.8	4.6	5.5
	1.5	1.6	2.25	3.35	3.85	4.2
3	7" w.c.	3.15	4.05	5.95	7.1	8.55
	11" w.c.	3.1	4.0	5.85	7.1	8.4
	1	2.8	3.65	5.25	6.45	7.55
	2	2.1	2.8	4.2	4.65	5.75
5	7" w.c.	4.1	5.45	7.85	9.35	11.1
	11" w.c.	4.05	5.45	7.8	9.25	11.0
	1	3.9	5.25	7.35	8.8	10.5
	2	3.5	4.6	6.5	7.95	9.45
	3	3.0	3.9	5.65	6.75	8.05
10	7" w.c.	6.05	8.0	11.0	13.4	15.8
	11" w.c.	6.0	8.0	11.0	13.4	15.8
	1	6.0	7.9	10.9	13.3	15.6
	2	5.8	7.75	10.6	12.9	15.2
	5	5.0	6.65	9.2	11.2	13.1
	8	3.5	4.7	6.45	7.8	9.25
15	1 or less	7.6	9.85	13.5	16.5	19.6
	2	7.5	9.8	13.4	16.4	19.4
	5	7.25	9.3	12.8	15.7	18.6
	8	6.55	8.45	11.6	14.2	16.8
	10	5.8	7.5	10.3	12.6	14.9
	13	4.05	5.25	7.2	8.8	10.4
20	3.5 or less	8.9	11.5	15.9	19.5	23.2
	5	8.85	11.4	15.8	19.3	23.0
	10	8.15	10.5	14.5	17.8	21.2
	15	6.4	8.25	11.4	14.0	16.7
	18	4.45	5.75	7.95	9.75	11.6
30	9 or less	11.5	14.9	20.6	25.1	30.4
	10	11.4	14.9	20.5	25.0	30.2
	15	10.9	14.2	19.6	23.8	28.8
	20	9.7	12.6	17.4	21.2	25.6
	25	7.5	9.75	13.4	16.3	19.8

Notes

K values are wide open for each orifice size.

Loading Ring set at 0° for PSIG outlet pressures. Loading ring set at 25° for inches w.c. outlet pressures. Exact settings may vary with individual pressure and load condition applications.

All capacities at 1% outlet pressure absolute pressure drop.

Set point at each outlet pressure was 500 cfh.

Maximum recommended inlet pressure (PSI to inches regulation) left of heavy shaded area.

 Do not operate orifice in shaded inlet pressure area.

CL838 IM CAPACITY TABLE 2 X 3 (CONTINUED)

Typical Capacity Info.	
Manufacturer	ROOTS Regulators
Type and model	CL838 IM
Regulator	
Inlet size	2-inch SCR 2-inch flanged
Outlet size	2-inch SCR 2-, 3-, 4-inch flanged
Spring color	Varies

Orifice Size		3/8"	1/2"	5/8"	3/4"	1"
Inlet Pressure PSIG	Outlet Pressure PSIG	Orifice constant factor K				
		535	535	535	535	535
40	14 or less	14.0	18.3	25.2	30.9	
	15	14.0	18.2	25.2	30.8	
	20	13.6	17.7	24.4	29.8	
	30	11.0	14.4	19.8	24.2	
50	19.5 or less	16.6	21.6	29.9	36.7	
	20	16.6	21.6	29.8	36.6	
	30	15.4	20.1	27.8	34.1	
60	24.5 or less	19.2	25.0	34.7	42.5	
	25	19.2	24.9	34.6	42.5	
	30	18.9	24.5	31.7	41.8	
75	30 or less	23.0	30.0			
100	30 or less	29.5	38.4			
125	30 or less	35.9	46.7			

- Notes**
- K values are wide open for each orifice size.
 - Loading Ring set at 0° for PSIG outlet pressures. Loading ring set at 25° for inches w.c. outlet pressures. Exact settings may vary with individual pressure and load condition applications.
 - All capacities at 1% outlet pressure absolute pressure drop.
 - Set point at each outlet pressure was 500 cfh.
 - Maximum recommended inlet pressure (PSI to inches regulation) left of heavy shaded area.
 - Do not operate orifice in shaded inlet pressure area.

CL838 IM CAPACITY TABLE 2 X 4

Capacities based on 0.6 Sp. Gr. gas at 14.7 PSIA and 60°F.

Typical Capacity Info.

Manufacturer	ROOTS Regulators
Type and model	CL838 IM
Regulator	
Inlet size	2-inch SCR 2-inch flanged
Outlet size	2-inch SCR 2-, 3-, 4-inch flanged
Spring color	Varies

Orifice Size		3/8"	1/2"	5/8"	3/4"	1"
Inlet Pressure PSIG	Outlet Pressure PSIG	Orifice constant factor K				
		535	690	980	1205	1480
2	7" w.c.	2.55	3.4	4.75	5.9	7.35
	11" w.c.	2.45	3.3	4.6	5.8	7.1
	1	2.05	2.75	3.8	4.7	5.9
	1.5	1.6	2.25	3.35	3.85	4.7
3	7" w.c.	3.15	4.25	5.95	7.3	9.1
	11" w.c.	3.1	4.15	5.85	7.15	8.9
	1	2.8	3.75	5.25	6.5	8.05
	2	2.1	2.85	4.2	4.85	6.1
5	7" w.c.	4.1	5.6	7.85	9.6	11.8
	11" w.c.	4.05	5.5	7.8	9.5	11.7
	1	3.9	5.3	7.45	9.0	11.1
	2	3.5	4.75	6.7	8.15	10.0
	3	3.0	4.05	5.7	6.9	8.55
10	7" w.c.	6.05	8.0	11.2	13.6	16.8
	11" w.c.	6.0	8.0	11.1	13.6	16.7
	1	6.0	7.9	11.0	13.4	16.5
	2	5.8	7.75	10.7	13.1	16.1
	5	5.0	6.65	9.3	11.3	14.0
	8	3.5	4.7	6.55	7.95	9.8
15	1 or less	7.6	9.85	13.7	16.7	20.8
	2	7.5	9.8	13.6	16.6	20.7
	5	7.25	9.3	13.0	15.9	19.8
	8	6.55	8.45	11.8	14.4	17.9
	10	5.8	7.5	10.5	12.8	15.9
	13	4.05	5.25	7.3	8.9	11.1
20	3.5 or less	8.9	11.5	16.4	20.0	24.6
	5	8.85	11.4	16.3	19.8	24.4
	10	8.15	10.5	15.0	18.2	22.4
	15	6.4	8.25	11.8	14.3	17.6
	18	4.45	5.75	8.2	10.0	12.3
30	9 or less	11.5	14.9	21.2	26.2	32.0
	10	11.4	14.9	21.1	26.1	31.8
	15	10.9	14.2	20.1	24.9	30.3
	20	9.7	12.6	17.9	22.1	26.9
	25	7.5	9.75	13.8	17.1	20.8

Notes

K values are wide open for each orifice size.

Loading Ring set at 0° for PSIG outlet pressures. Loading ring set at 25° for inches w.c. outlet pressures. Exact settings may vary with individual pressure and load condition applications.

All capacities at 1% outlet pressure absolute pressure drop.

Set point at each outlet pressure was 500 cfh.

CL838 IM CAPACITY TABLE 2 X 4 (CONTINUED)

Typical Capacity Info.	
Manufacturer	ROOTS Regulators
Type and model	CL838 IM
Regulator	
Inlet size	2-inch SCR 2-inch flanged
Outlet size	2-inch SCR 2-, 3-, 4-inch flanged
Spring color	Varies

Orifice size		3/8"	1/2"	5/8"	3/4"	1"
Inlet Pressure PSIG	Outlet Pressure PSIG	Orifice constant factor K				
		535	535	535	535	535
40	14 or less	14.0	18.3	25.9	32.2	
	15	14.0	18.2	25.9	32.1	
	20	13.6	17.7	25.1	31.1	
	30	11.0	14.4	20.4	25.3	
50	19.5 or less	16.6	21.6	30.7	38.1	
	20	16.6	21.6	30.6	38.0	
	30	15.4	20.1	28.5	35.4	
60	24.5 or less	19.2	25.0	35.4	44.0	
	25	19.2	24.9	35.4	44.0	
	30	18.9	24.5	34.8	43.3	
75	30 or less	23.0	30.0			
100	30 or less	29.5	38.4			
125	30 or less	35.9	46.7			

Notes

K values are wide open for each orifice size.

Loading Ring set at 0° for PSIG outlet pressures. Loading ring set at 25° for inches w.c. outlet pressures. Exact settings may vary with individual pressure and load condition applications.

All capacities at 1% outlet pressure absolute pressure drop.

Set point at each outlet pressure was 500 cfh.

 Do not operate orifice in shaded inlet pressure area.

CL838 IM-1 PERFORMANCE CURVES

1 PSIG Set Point*

Inlet size	2" Flanged
Outlet size	4" Flanged
Orifice size	3/4"
Inlet pressure	20 PSIG
Spring range	Silver/white (pilots), green closing
Position no.	Horizontal
Bolt circle diameter	12-1/16"

* Set point 1 PSIG with 40 PSIG inlet @ 500 SCFH. All test results are reported at a base of 14.7 PSIG at 60° F and with 0.6 S.G. gas. Loading rings at 0 degrees.

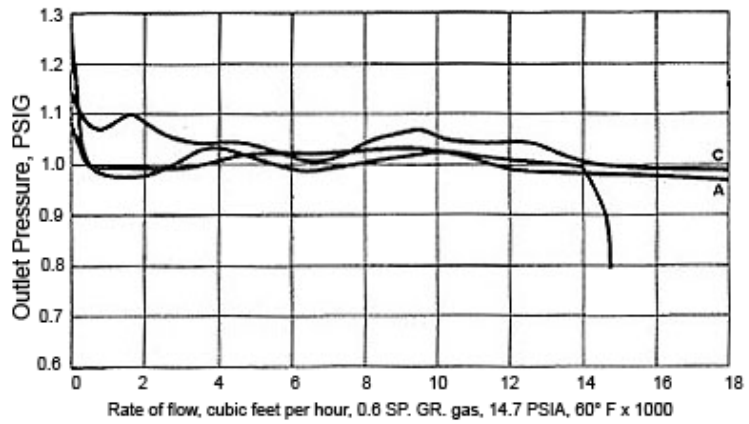

- A. Normal regulation
- B. Failed with foreign particle.
- C. Failed with eroded valve seat.

ASSEMBLY POSITIONS

The six basic assembly positions are shown here.

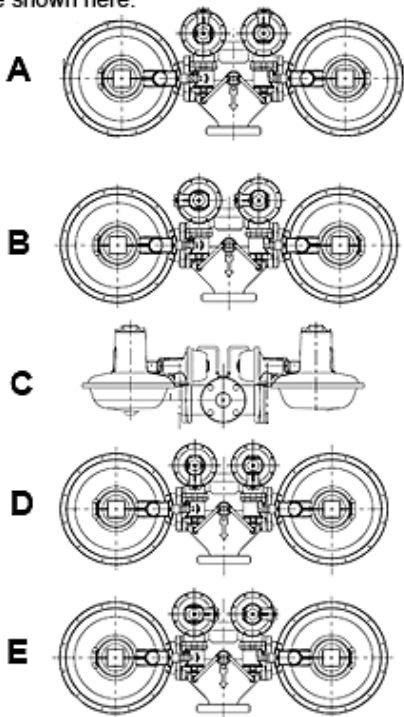

Please specify the assembly position by letter designation when ordering.

CL838 R, N, D, AND M PARTS LIST

Part Number	Description
753418SU	Main upper diaphragm case
760083	Main case seal cap
736011	Adjustment screw guide assembly
765607	Main case seal cap gasket
769250	Badge
755071	Drive Screw 2 x 1/8
765211	Valve seat
761731	Deflector
751933	Retainer plate
755721	Retainer plate snap ring
755223	Lever pin screw
754836	Pin lever
766301	Main case diaphragm
76104102	Upper diaphragm plate
756077	Lower diaphragm plate
754361	Main case stop stem
755115	Set screw, lower diaphragm plate
761471	Closing spring guide
761083	Secondary diaphragm plate
755531	Hex plated nut 5/16-18, main diaphragm assembly

Closing spring, please specify	
762341	Orange closing spring
762351	Brown closing spring
762353	Green closing spring
762355	Black closing spring
Valve body, please specify	
750957	2 x 2 valve body
750968	2 x 2 FL valve body
750977	2 x 3 FL valve body
750987	2 x 4 FL valve body
Orifice, please specify	
758398	1/4"
758401	1/2"
758404	3/4"
758407	1'
758410	1-1/4"
758413	1-3/8"
758416	5/8"
758419	3/8"
759161	3/8" IM complete assembly
759163	3/8" IM vented complete assembly
759165	1/2" IM complete assembly
759167	1/2" IM vented complete assembly
759171	5/8" IM complete assembly
759173	5/8" IM vented complete assembly
759175	3/4" IM complete assembly
759177	3/4" IM vented complete assembly
759181	1" IM complete assembly
759183	1" IM vented complete assembly
761771	Loading ring
80001901	Valve body gasket
755391-001	3/8 x 16 x 1 -5/16 Hex head retainer plate screw
755311-001	1/4-20 x 1 Hex head high carbon case screw
755513-001	1/4-20 Hex high carbon nut
768143	1 x 2 nipple
768203	3/4 x 1/4 reducer
768533	Control line, stainless steel
769401	Label cap warning
765525	O-Ring, stationary orifice
Upper and lower case assemblies	
710056	Main upper case assembly
715065	Main lower case, bushing assembly
715030	Main lower case 4:1 assembly
715066	Main lower case, bushing assembly
715031	Main lower case 3.5:1, monitor assembly
761275	Lever, standard main case
761271	Lever, monitor 3.5:1

754191	Main case valve stem, standard
754193	Main case valve stem, monitor
720040	Diaphragm, main case
755007	Main case valve stem roll pin, standard
755009	Main case valve stem roll pin, monitor
Orifice parts, please specify	
758431	1" IM stationary
758434	5/8" and 3/4" IM stationary
758437	3/8" and 1/2" IM stationary
759151	3/8" IM, female with gasket
759153	1/2" IM, female with gasket
759155	5/8" IM, female with gasket
759157	3/4" IM, female with gasket
759159	1" IM, female with gasket
762451	3/8" and 1/2" IM spring red cut off
762453	5/8" and 3/4" IM spring blue cut off
762455	1" spring yellow cut off
758471	3/8" male sliding
758477	1/2" male sliding
758484	5/8" male sliding
758490	3/4" male sliding
758497	1" male sliding
758480	1/2" IMV male sliding
758487	5/8" IMV male sliding
758493	3/4" IMV male sliding
758498	1" IMV male sliding
Orifice O-Ring, please specify	
765523	O-Ring, 126 1"
765531	O-Ring, 116 3/8" and 1/2"
765533	O-Ring, 121 5/8" and 3/4"
768263	ELL 90° 1/4-18 x 3/8" tube
768264	ELL° 14/-18x3/8 S.S. two-piece swageloc
768265	ELL° 14/-18x3/8 SS two-piece tube S.S.
768231	Tee, 1/4" male
#1 Pilot assembly, please specify regulator position	
700101	Green/white
700102	Blue/white
700103	Dark green
700104	Silver/white
700105	Yellow/white
700106	Red/white
700107	White
700205	Silver
700201	Brown
700202	Green
700203	Black
700204	Blue

700205	Silver
700206	Green/white
Pilot parts	
752311	Lower diaphragm case CL 1 & 2 pilot as match
761201	Lever CL1 pilot
754021	Aluminum valve stem CL1 pilot
765021	Standard pilot valve seat
751955	Pilot retainer plate
755725	Retainer ring, pilot retainer plate
754832	Pin lever
750044	VB 3/4 x 1, 90°
757255	1/8" brass, pilot orifice
761753	White 2-hole loading ring
765753	Gasket valve body
755378-001	5/16 - 18 x 1 - 1/8" Hex head slotted
755175-001	10-24 x 7/8 SOC HD
755855	Lock washer, .190 split
800047	CL1 pilot diaphragm support
715078	CL1 pilot lower case assembly
760217	CL1 adjustment screw, aluminum
760053	CL1 pilot seal cap
765503	O-Ring, 021 CL1 seal cap
762935	3/4" CL1 pilot vent screen
754806	Valve disc pin CL1 pilot vent
762651	Standard CL1 vent spring
765181	Vent valve disc, no hole CL1 pilot
753027	CL1 pilot UP diaphragm case
765685	CL1 pilot vent valve seat
710031	UP case assembly CL1 pilot, no breath
755141-001	8 - 32 x 5/16 Phillister head screw lever pin/diaphragm support bracket
766010	CL1 diaphragm, pilot
720043	CL1 diaphragm assembly, pilot, 14" relief
76100202	Upper diaphragm plate CL1 pilot
756021	Lower diaphragm plate CL1 pilot
762051	14 IWC, Relief spring CL1 pilot
75490601	Stop stem guide bushing CL1 pilot
CL1 Adjustment spring, please specify	
762013	Blue/white
762017	Silver/white
762021	Yellow/white
762027	Red/white
762029	White
762034	Yellow/blue
762117	Dark green
762119	Lt. green
762129	Silver
730003	Seal cap assembly

715028	CL2 pilot lower case assembly
760201	CL2 pilot adjustment screw
765603	CL2 pilot seal cap gasket
762905	CL2 pilot spiral vent screen
75572701	RTNG ring, vent
753044	UP diaphragm case
730101	Vent valve assembly
710044	UP case assembly
760201	Adjustment screw
765603	Seal cap gasket
762905	Spiral vent screen
75572701	RTNG ring, CL2 pilot vent
753044	CL2 pilot UP case assembly
730101	CL2 pilot vent valve assembly
710044	CL2 pilot UP case assembly
755141-001	8 - 32 x 5/16" Phillister head lever pin screw
766031	CL2 pilot diaphragm
720041	Diaphragm assembly CL2 pilot, brown spring
761011	CL2 pilot upper diaphragm plate
756001	CL2 pilot lower diaphragm plate
755191	1/4 x 1.25 Shieldscrew, CL2 stop stem
761411	CL2 pilot relief spring guide
762081	Relief spring, brown
765711	Relief valve seal gasket CL2 pilot
756005	Diaphragm plate screw CL2 pilot
755001	Roll pin for lower diaphragm plate CL2 pilot
CL2 pilot adjustment spring, please specify	
762401	Brown, relief
762403	Green, relief
762405	Black
762407	Blue
762409	Silver
762417	Green/white
755821	Diaphragm anti-friction washer CL2 pilot

SPECIAL TOOLS

Part No.	Description
799027	Machined orifice wrench
799051	Adjustment wrench
768481	Filter-control line
768485	Filter, control line PIF-640 3/4"
80002001	Seal wire, no lead
80002002	Seal wire, no lead, 24

Notes:

1. CL838 IMN parts are identical to CL838N parts except for the orifice assembly.
2. CL838 IMR parts are identical to CL838R parts except for the orifice assembly.
3. CL838 IMRV parts are identical to CL838R parts except for the orifice assembly.

TORQUE SPECIFICATIONS

Retainer Plate Screws	100 in. lbs.
Orifice	600 in. lbs.
Orifice (IM)	300 in. lbs.
Margin screws (item no.648)	50 in. lbs.
Margin screws (item no. 64A)	30 in. lbs.

VENT LINES FOR REGULATORS

When constructing vent lines to be attached to regulators installed indoors, follow a few basic rules:

- a. Never use pipe sizes smaller than the vent size; smaller pipe sizes restrict the gas flow. If a long gas run must be used, ROOTS Regulators advises increasing the pipe one nominal size every ten feet to keep the flow restriction as low as possible.
- b. Keep the vent line length as short as possible to minimize the restriction and reduce the vent's tendency to cause regulator pulsation. c. Support the vent pipe to eliminate strain on the regulator diaphragm case.
- c. Always point outdoor vent pipes in the downward position to reduce the possibility of rain, snow, sleet, and other moisture entering the pipe. Install a bug screen in the end of the pipe.
- d. Do not locate the vent line terminus near windows, fans, or other ventilation equipment. See the installation instructions furnished with the regulator.
- e. Adhere to all applicable codes and regulations.
- f. If your vent pipe causes regulator pulsation, consult your sales representative or manufacturer.
- g. ROOTS Regulators strongly recommends running a separate vent line for each regulator. Headers with various installed devices can cause regulator malfunction.

Caution Ensure the end of the vent line is away from ANY potential ignition sources. It is the installer's responsibility to verify the vent line is exhausting to a safe environment.

INSTALLATION

Warning ROOTS Regulators does not endorse or warrant the completeness or accuracy of any third party regulator installation procedures or practices, unless otherwise provided in writing by ROOTS Regulators. Follow your company's standard operating procedures regarding the use of personal protection equipment (PPE). Adhere to guidelines issued by your company in addition to those given in this document when regulators are installed.

- a. Remove all shipping plugs from the regulator inlet, outlet, and vent before installation.
- b. Verify the piping interior and regulator inlet and outlet are clean and free of dirt, pipe dope, and other debris. Dirt and other foreign materials entering the regulator can cause a loss of pressure control.
- c. Apply pipe joint sealant to the male pipe threads. Do not use pipe joint material on the regulator's female threads. Joint sealant could become lodged in the regulator and cause a loss of pressure control.
- d. Gas must flow through the regulator's valve body in the direction cast on the regulator body. Gas flowing in the wrong direction can overpressure and cause damage to the regulator.
- e. The pilot diaphragm casing can be mounted in any position relative to the body through a full 360° angle at 90° increments.
- f. When the regulator is installed OUTDOORS, the vent must always be positioned so that rain, snow, moisture or foreign particles cannot enter the vent opening. ROOTS Regulators recommends positioning the pilot vent downward to avoid entry of water or other matter which could interfere with the proper operation of the regulator. The vent should be located away from building eaves, window openings, building air intakes and above the expected snow level at the site. The vent opening should be inspected periodically to insure it does not become blocked by foreign material as outlined in DOT PHMSA-RSPA-2004-19856.
- g. When the regulator is installed INDOORS, the vent must be piped to the outside atmosphere using the shortest length of pipe, the fewest possible pipe elbows, and a pipe diameter as large as the vent size or larger. USING VENT PIPE SMALLER THAN THE VENT CONNECTION LIMITS THE REGULATOR'S INTERNAL RELIEF VALVE CAPACITY. The outlet end of the pipe must be protected from moisture and the entrance of foreign particles. The regulator should be specified by the user with the size vent and pipe threads desired to make the vent pipe connection.

START-UP PROCEDURE

Warning The seal caps for the main diaphragm cases must always be installed and wrench tight before introducing gas flow to the regulator and for as long as gas pressure is present in the regulator.

- a. Mount a pressure gauge downstream of the regulator to monitor the downstream pressure.
 - b. With the downstream pressure valve closed, slowly open the inlet valve. The outlet pressure should rise to slightly more than the set-point. Verify there are no leaks and all connections are tight.
 - c. The regulator was pre-set at the factory to match the order specifications. If regulator readjustments are necessary, the adjustment is made to the pilots only. While the regulator is under steady flow conditions of 500 cfh or more, remove the pilot regulator seal caps.
-

Caution Never remove or loosen the main diaphragm case seal caps while gas is present (under pressure) in the regulator.

- d. To increase the outlet pressure, turn each adjustment screw clockwise in equal increments until the outlet pressure is about 10% below desired gauge pressure. Adjust one screw clockwise to the desired outlet pressure. Turn the second screw clockwise until a slight increase in the outlet pressure is observed. Make slight counterclockwise adjustments to achieve the desired outlet pressure. Always set both pilots at the same pressure to keep both valves operating in unison.
- e. To decrease the outlet pressure, turn each adjustment screw counterclockwise in equal increments until the outlet pressure is about 10% below the desired outlet pressure. Adjust one screw clockwise to the desired outlet pressure. Turn the second screw clockwise until a slight increase in outlet pressure is observed. Make slight counterclockwise adjustments to achieve the desired outlet pressure. Always set both pilots at the same pressure to keep both valves operating in unison.
- f. Replace the seal cap and check for leaks after the desired outlet pressure is achieved.

The regulator is ready for operation.

SAFETY WARNING

This product, as of the date of manufacture, is designed and tested to conform to all governmental and industry safety standards as they may apply to the manufacturer. The purchaser/user of this product must comply with all fire control, building codes, and other safety regulations governing the application, installation, operation, and general use of this regulator to avoid leaking gas hazards resulting from improper installation, startup or use of this product.

ROOTS Regulators strongly recommends installation by a qualified professional and periodic inspection of pressure regulators (inspections may be required by local applicable codes or regulations).

Inspections should include checking for gas quality, cycle numbers, external environmental changes, and operating conditions that impact wear on the regulator's moving parts. To ensure safe and efficient operation of this product, replace worn or damaged parts found during inspection.

Limited Warranty

ROOTS Regulators are subject to the terms and conditions of the Natural Gas Solutions North America, LLC General Terms & Conditions For Sale of Products, Parts and Services, and no other terms shall apply, unless agreed upon by the parties in writing. The Natural Gas Solutions North America, LLC General Terms & Conditions For Sale of Products, Parts and Services can be found on the Dresser Utility website: dresserutility.com/forms-questionnaires-and-terms-conditions-sale.

Ordering Information

Specify:

1. Inlet and Outlet Connection Size and Type
2. Model Number
3. Outlet pressure desired
4. Pilot needed
5. Inlet pressure range
6. Type of gas and maximum capacity required
7. Assembly position number (see chart below)

Special requirements such as tagging, 1/8" pipe plug tap, seal wire, etc.

ROOTS Regulator + ROOTS Meter Compatibility

<u>Small</u>	<u>Regular</u>	<u>Large</u>
102M125	38M-102M	102M125

ROOTS Regulators

16240 Port Northwest Drive
Houston, TX 77041
T: 1-800-521-1114
F: 1-800-335-5224

© 2025 Natural Gas Solutions North America, LLC – All rights reserved. Dresser Utility Solutions reserves the right to make changes in specifications and features shown herein, or discontinue the product described at any time without notice or obligation. Contact your Dresser Utility Solutions representative for the most current information. The Dresser Logo and all Trademarks containing the term "Dresser" are the property of Dresser, LLC, a subsidiary of Baker Hughes.

