

CL38 Regulator

Commercial & Industrial Regulator

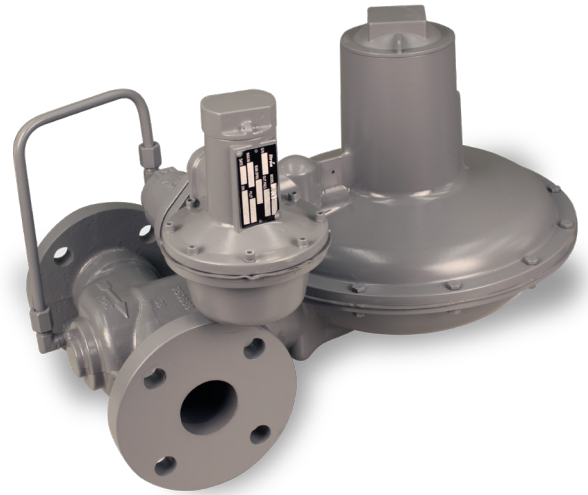

The CL38 is a constant pressure loaded regulator for use where a closer pounds to pounds regulation is desired than can be obtained from conventional spring loaded regulators. Since, it requires an inlet pressure supply of only 1/2 PSIG above outlet pressure, this unit can be used where demand type loading will not meet the low pressure differential. The key feature of the CL38, compared to other CL series regulators, is the large 2" valve body which is designed to handle the increased gas flows of the larger orifice sizes.

Applications

Appropriate for commercial and industrial applications where very accurate pressure control is required such as "fixed-factor" metering applications or large boiler and furnace applications.

Option Designations*

- » CL38
Internal registration
(no control line required)
- » CL38M
Equipped with closed-throat and control line tap for remote downstream control
(External registration)
- » CL38IM
Equipped with an Internal Monitor orifice; Internal Registration
(no control line required)
- » CL38IMV
Equipped with an Internal Monitor Orifice plus Vent hole option for Monitor warning indication; Internal Registration
(no control line required)

*All versions are available with either -1 or -2 pilot:

- » #1 pilot for 5" w.c. to 5 PSIG outlet pressure
(Model Name Example: CL38-1)
- » #2 pilot for 1 PSIG to 30 PSIG outlet pressure
(Model Name Example: CL38-2)

Benefits

- » Economical
- » Light weight
- » Accurate pressure control for "fixed-factor" measurement applications
- » No special start-up procedures required
- » Internal Monitor version eliminates the need for external relief valves or separate monitoring devices
- » No special tools required for outlet pressure adjustment
- » No minimum differential pressure requirement

Features

- » Constant loaded pilot design ("fixed-factor" pressure control)
- » Interchangeable brass orifice
- » Internal lower diaphragm chamber pressure flow control
- » 133 in² of diaphragm area
- » Spring-loaded pilot internal relief valve assembly
- » Field interchangeable pilot adjustment spring
- » Controlled internal bleed hole eliminates pulsation
- » Wide range of valve body sizes including NPT and Flange connections
- » 16 different available assembly positions
- » Capacities from 1500 CFH to 20,000 CFH available

SHIPPING WEIGHT

One regulator per box

Box weight: 33 lbs.

CL38 DIMENSIONS (INCHES)

Valve Body	A	B	C	D	E	F	G	H	I
NPT (all sizes)	19-5/16	12-3/4	7-5/16	8-11/16	10	4-5/16	4-7/8	5-3/4	2-7/8
Flanged (all sizes)	20-1/2	12-3/4	7-5/16	8-11/16	10	4-5/16	4-7/8	10	5

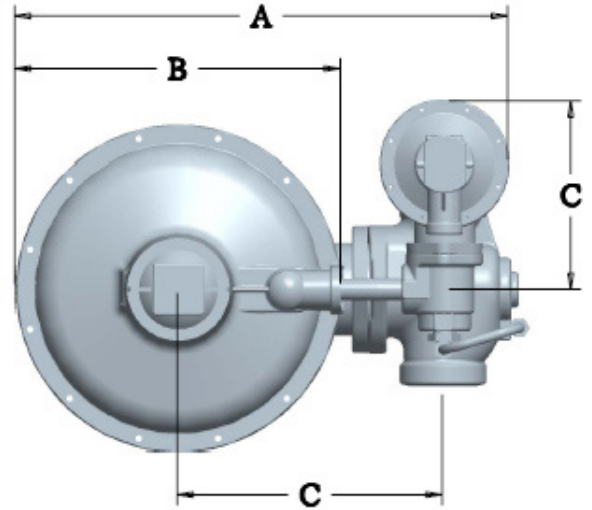
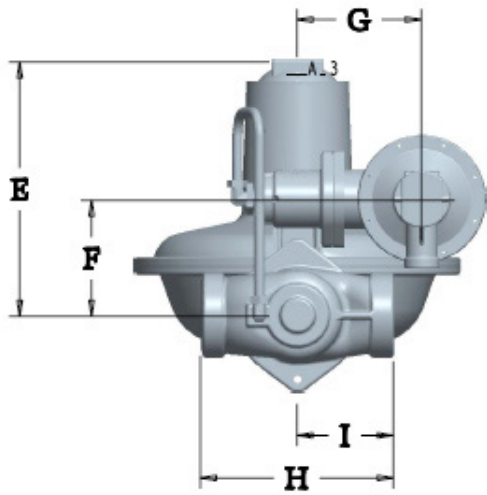

OPERATING SCHEMATIC

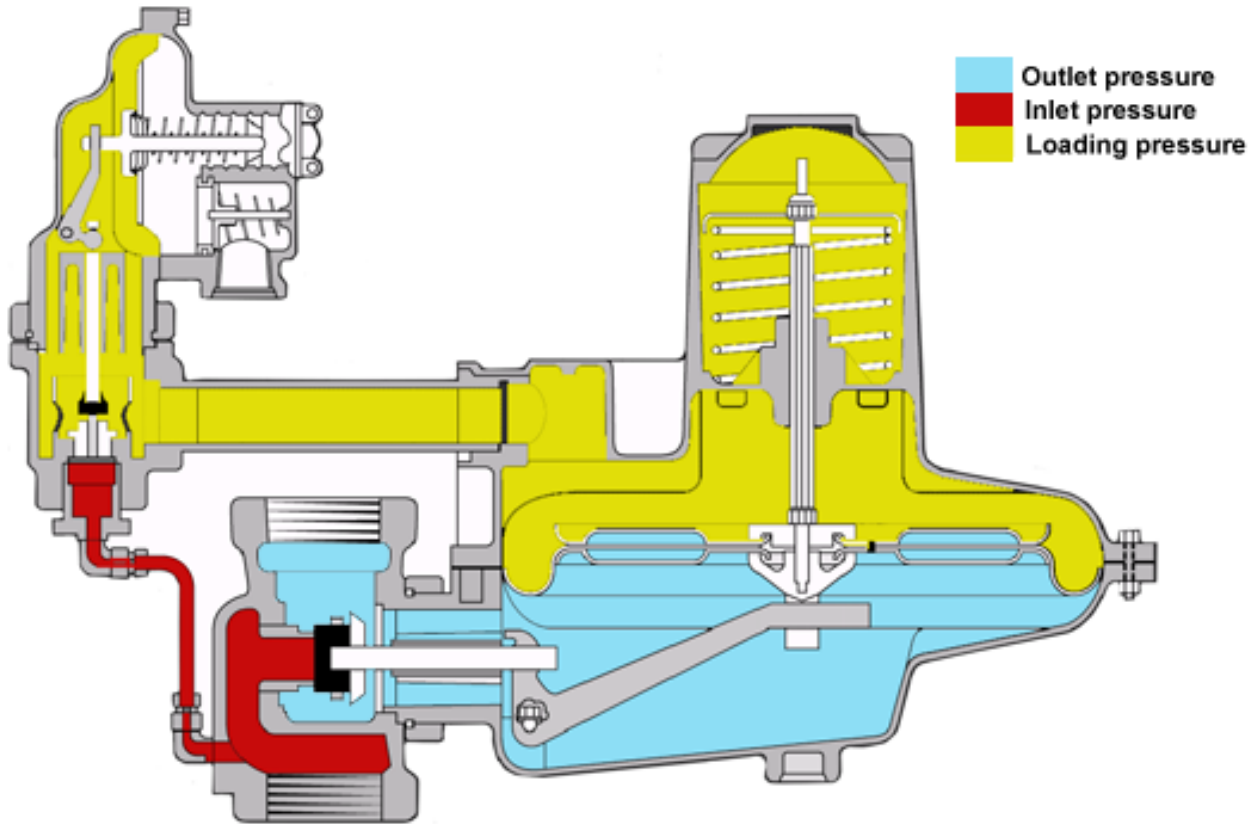

CL38 CLOSING SPRING DATA

Spring Data, Spring Color Outlet Pressure Range*

CL-38-1 and 2							
Main Regulator Closing Spring Data							
	Orifice Size						
	3/8"	1/2"	5/8"	3/4"	1"	1-1/4"	1-3/8"
Closing Spring Color	Maximum Differential Pressure Across Orifices PSIG*						
Orange	75	50	30	21	10	10	7
Brown	265	140	90	60	30	26	19
Green	-	200	120	80	40	32	25
Black	-	-	245	160	85	61	51

CL-38 IM, 1 and 2					
Main Regulator Closing Spring Data					
	Orifice Size				
	3/8"	1/2"	5/8"	3/4"	1"
Closing Spring Color	Maximum Differential Pressure Across Orifices PSIG*				
Green	200	200	120	80	40
Black	-	-	245	160	85

Spring Ranges				
CL-38-1				
Pilot Loading Spring	Closing Spring			
	Orange	Brown	Green	Black
	Inches w.c.			
Green/white	5.1 - 7.3	-	-	-
Blue/white	7.2 - 13.6	4.1 - 10.1	4.0 - 9.5	-
Dark green	13.4 - 18.0	10.2 - 13.9	9.1 - 13.1	6.2 - 7.2
	PSIG			
Silver/white	0.6 - 1.2	0.5 - 1.0	0.5 - 1.0	0.4 - 1.0
Yellow/white	1.7 - 2.2	1.6 - 2.1	1.5 - 2.1	1.3 - 2.0
Red/white	2.2 - 4.0	2.1 - 3.9	2.0 - 3.8	2.0 - 3.7
White	3.1 - 5.0	3.0 - 5.0	3.0 - 5.0	3.0 - 5.0

*The maximum recommended pressure differential and closing spring are based on a 2:1 safety factor.

Note: The maximum emergency pressure differential is 75% of two times the values shown in the table above.

CL-38 IM-1				
Pilot Loading Spring	Closing Spring			
	Orange	Brown	Green	Black
	Inches w.c.			
Blue/white	-	-	4.0 - 9.5	-
Dark green	-	-	11.0 - 14.3	4.0 - 6.2
Silver/white	-	-	-	0.4 - 1.0
	PSIG			
Silver/white	-	-	0.5 - 1.0	-
Yellow/white	-	-	1.5 - 2.3	1.3 - 1.9
Red/white	-	-	2.1 - 3.8	1.9 - 3.7
White	-	-	3.0 - 5.0	3.0 - 5.0

The maximum recommended outlet pressure is 5 PSIG for a CL38-1 regulator.

CL-38-2				
Pilot Loading Spring	Closing Spring			
	Orange	Brown	Green	Black
	PSIG			
Brown	0.75 - 2.25	0.75 - 2.1	0.75 - 2.0	0.75 - 1.8
Green	1.5 - 10.2	1.5 - 9.8	1.5 - 9.6	1.5 - 9.2
Black	5.0 - 12.8	5.0 - 12.6	5.0 - 12.4	5.0 - 11.6
Blue	9.0 - 29.3	9.0 - 29.0	9.0 - 28.7	9.0 - 28.2
Silver	25 - 30	25 - 30	25 - 30	25 - 30

CL-38 IM-2				
Pilot Loading Spring	Closing Spring			
	Orange	Brown	Green	Black
	PSIG			
Brown	-	-	0.75 - 2.1	0.75 - 1.8
Green	-	-	1.5 - 10.0	1.5 - 9.2
Black	-	-	5.0 - 12.9	5.0 - 12.0
Blue	-	-	9.0 - 28.4	9.0 - 27.7
Silver	-	-	25 - 30	25 - 30

The maximum recommended outlet pressure is 30 PSIG for a CL-38-2 regulator.

Outlet Pressure	
Model	Pressure
CL38-1	5-inch w.c. to 5 PSIG
CL38-2	1 to 30 PSIG

ORIFICE DATA, WIDE OPEN FLOW COEFFICIENTS AND MAXIMUM PRESSURES

Orifice Size (inches)	K-Factor	Maximum Operating Inlet Pressure (PSIG)	Maximum Emergency Inlet Pressure (PSIG)	Maximum Emergency Outlet Pressure (PSIG)
CL38 1 and 2				
3/8	290	150	150% of the maximum pressure differential of the closing spring	40
1/2	495	150		
5/8	700	150		
3/4	910	150		
1	1240	115		
1-1/4	1500	90		
1-3/8	1725	80		
CL38 IM				
3/8	290	150	150% of the maximum pressure differential of the closing spring	40
1/2	425	150		
5/8	615	150		
3/4	720	150		
1	875	115		

OPERATING TEMPERATURE

» -20°F to 150°F

Available pilot vent sizes	3/4" NPT
Loading ring position	Varies
Other available options	Seal wire to indicate unapproved tampering
	Pilot supply line filter (contact factory for specifications)
	Stainless steel supply line fittings

CONSTRUCTION

ROOTS Regulators takes pride in delivering products with the utmost concern for safety, quality, and customer satisfaction.

Material Construction:

Valve Body	High tensile strength cast iron (ASTM A-126, Class A)
Orifice (Standard and IM)	Brass (ASTM B-16, Alloy 360)
Valve Seat	Buna-N
Valve Stem	Plated steel (AISI 1215)
Lever Pin	Stainless steel (Type 303)
Lever	Zinc and dichromate plated steel (AISI C1010)
Upper Diaphragm Plate	Die cast aluminum (ASTM B-85)
Lower Diaphragm Plate	Die cast aluminum (ASTM B-85 Alloy SC84A)
Diaphragm	Buna-N and nylon reinforcing fabric
Vent Valve/Seat	Neoprene
Vent Screen	Stainless steel (16 mesh)
Diaphragm Case	Die cast aluminum (ASTM B-85 - Alloy SC84A)

Connection Sizes		
Type	Inlet	Outlet
Straight Valve Body, screwed	1-1/2	1-1/2
	1-1/2	2
	2	2
Flanged Valve Body	2	2
	3*	3*

*With 2-inch bore.

CORRECTION FACTORS FOR NON-NATURAL GAS APPLICATIONS

The may be used to control gases other than natural gas. To determine the capacity for gases other than natural gas, multiply the values within the capacity tables by a correction factor. The table below lists the correction factors for some of the more common gases.

Gas Type	Specific Gravity	Correction Factor (CF)
Air	1.00	0.77
Butane	2.01	0.55
Carbon Dioxide (Dry)	1.52	0.63
Carbon Monoxide (Dry)	0.97	0.79
Natural Gas	0.60	1.00
Nitrogen	0.97	0.79
Propane	1.53	0.63
Propane-Air-Mix	1.20	0.71

To calculate the correction factor for gases not listed in the table above, use the gases' specific gravity and insert it in the formula listed below:

$$\text{Correction Factor (CF)} = \sqrt{\frac{SG_1}{SG_2}}$$

Where:

SG1 = Specific gravity of the gas in which the capacity is published.

SG2 = Specific gravity of the gas to be controlled.

Wide Open Flow Calculations

For wide-open orifice flow calculations use the following equations:

For $\frac{P_1}{P_2} < 1.89$

use: $Q = K\sqrt{P_2(P_1 - P_2)}$

For $\frac{P_1}{P_2} > 1.89$

use: $Q = \frac{KP_1}{2}$

Where:

P1 = Absolute Inlet Pressure (PSIA)

P2 = Absolute Outlet Pressure (PSIA)

Q = Flow Rate (SCFH)

K = Orifice Coefficient (SCFH/PSI)

CL38 CONSTANT LOADED REGULATOR CAPACITY TABLE

1% Absolute Droop

Capacities in SCFH 0.6 gas, base conditions of 14.7 PSIA and 60°F.

Typical Capacity Info.

Manufacturer	ROOTS Regulators
Type and model	CL38-1 CL38-2
Regulator	
Inlet size:	2"
Outlet size:	2"

Inlet Pressure PSIG	Outlet Pressure PSIG	Orifice Size						
		3/8	1/2	5/8	3/4	1	1-1/4	1-3/8
		Orifice Constant Factor K						
		290	495	700	910	1240	1500	1725
		Capacities in 1000 SCFH						
2	7" w.c.	1.45	2.3	3.2	4.35	6.1	7.5	8.4
	11" w.c.	1.4	2.25	3.15	4.25	5.7	7.3	8.1
	1 PSIG	1.15	1.85	2.7	3.6	4.8	6.1	6.75
	1.5 PSIG	0.9	1.5	2.05	2.75	3.85	5.05	5.6
3	7" w.c.	1.8	2.85	4.05	5.45	7.5	9.45	10.4
	11" w.c.	1.8	2.85	4.0	5.35	7.3	9.3	10.2
	1 PSIG	1.6	2.55	3.55	4.9	7.0	8.35	9.2
	2 PSIG	1.2	2.05	2.8	3.7	4.9	6.35	7.0
5	7" w.c.	2.3	3.85	5.45	7.25	10.0	12.3	13.5
	11" w.c.	2.3	3.8	5.45	7.2	9.9	12.2	13.4
	1 PSIG	2.2	3.55	5.05	6.85	9.45	11.6	12.7
	2 PSIG	2.0	3.2	4.5	6.2	8.5	10.4	11.5
	3 PSIG	1.7	2.75	3.9	5.15	7.15	8.9	9.55
10	7" w.c.	3.4	5.65	7.95	10.4	14.1	17.8	19.6
	11" w.c.	3.4	5.65	7.95	10.4	14.1	17.8	19.6
	1 PSIG	3.4	5.55	7.85	10.2	14.0	17.6	19.3
	2 PSIG	3.2	5.4	7.6	9.9	13.6	17.1	18.8
	5 PSIG	2.8	4.65	6.6	8.6	11.8	14.8	16.3
	8 PSIG	1.9	3.25	4.65	6.05	8.25	10.4	11.5
15	1 PSIG or less	4.2	6.95	10.0	12.9	17.8	21.9	25.2
	2 PSIG	4.2	6.9	10.0	12.8	17.7	21.7	25.0
	5 PSIG	4.0	6.55	9.55	12.2	16.9	20.8	23.9
	8 PSIG	3.6	5.95	8.6	11.0	15.2	18.7	21.6
	10 PSIG	3.2	5.25	7.65	9.8	13.5	16.7	19.2
	13 PSIG	2.25	3.7	5.3	6.85	9.45	11.6	13.3
20	3.5 PSIG or less	4.9	8.15	11.8	15.2	20.8	25.5	29.4
	5 PSIG	4.9	8.05	11.7	15.0	20.6	25.3	29.1
	10 PSIG	4.5	7.4	10.7	13.8	18.9	23.7	26.8
	15 PSIG	3.55	5.85	8.45	10.9	14.9	18.4	21.1
	18 PSIG	2.45	4.05	5.85	7.6	10.4	12.8	14.7
30	9 PSIG or less	6.35	10.6	15.4	19.6	26.8	32.9	37.9
	10 PSIG	6.3	10.5	15.3	19.5	26.7	32.8	37.7
	15 PSIG	6.0	10.0	14.5	18.5	25.4	31.2	35.9
	20 PSIG	5.35	8.95	12.9	16.5	22.6	27.8	31.9
	25 PSIG	4.15	6.9	10.0	12.7	17.4	21.4	24.7

Notes:

K valves are wide open for each orifice size.

Loading ring set at 0° for PSIG outlet pressures. Loading ring set at 25° for inches w.c. outlet pressures. Exact settings may vary with individual applications of pressures and load conditions.

Set point at each outlet pressure was reached using 200 SCFH of flow.

CL38 CONSTANT LOADED REGULATOR CAPACITY TABLE CONTINUED

1% Absolute Droop

Capacities in SCFH 0.6 gas, base conditions of 14.7 PSIA and 60°F.

Typical Capacity Info.

Manufacturer	ROOTS Regulators
Type and model	CL38-1 CL38-2
Regulator	
Inlet size:	2"
Outlet size:	2"

Inlet Pressure PSIG	Outlet Pressure PSIG	Orifice Size						
		3/8	1/2	5/8	3/4	1	1-1/4	1-3/8
		Orifice Constant Factor K						
		290	495	700	910	1240	1500	1725
Capacities in 1000 SCFH								
40	14 PSIG or less	7.75	13.1	18.8	24.6	32.8	40.3	46.5
	15 PSIG	7.75	13.0	18.7	24.5	32.7	40.2	46.3
	20 PSIG	7.5	12.6	18.1	23.7	31.7	38.9	44.9
	30 PSIG	6.1	10.2	14.7	19.3	25.8	31.7	36.5
50	19.5 PSIG or less	9.2	15.6	22.3	29.1	38.8	47.7	54.9
	20 PSIG	9.2	15.6	22.2	29.0	38.6	47.5	54.6
	30 PSIG	8.55	14.5	20.6	27.0	36.0	44.3	51.1
60	24.5 PSIG or less	10.6	18.1	25.7	33.6	44.8	55.2	63.4
	25 PSIG	10.6	18.0	25.6	33.4	44.6	55.0	63.1
	30PSIG	10.4	17.7	25.2	32.9	44.0	54.1	62.4
75	30 PSIG or less	12.7	21.9	31.0	40.3	53.8	66.3	76.2
100	30 PSIG or less	16.3	28.1	39.5	51.6	68.8		
125	30 PSIG or less	19.9	34.2	48.1	62.8			

Notes:

K valves are wide open for each orifice size.

Loading ring set at 0° for PSIG outlet pressures. Loading ring set at 25° for inches w.c. outlet pressures. Exact settings may vary with individual applications of pressures and load conditions.

Set point at each outlet pressure was reached using 200 SCFH of flow.

Figures below heavy line may show differentials above allowable limits. Check closing spring tables to be sure.

 Do not operate orifice in shaded inlet pressure area.

CL38 PERFORMANCE CURVES

Type and model	CL38
Inlet size:	2-inch NPT
Outlet size:	2-inch NPT
Orifice size:	1"

All test results are reported at a base of 14.7 PSIG at 60°F and with 0.6 S.G. gas. Loading ring @ 0 degrees.

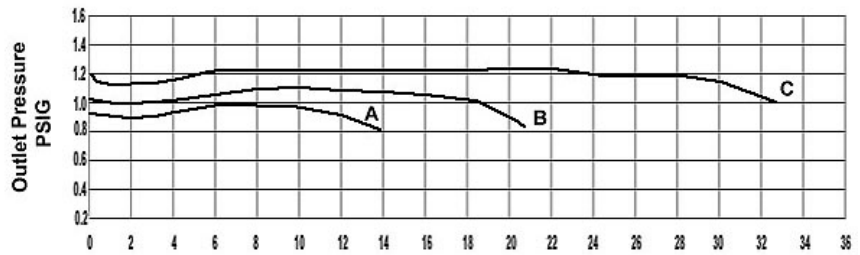

A. 10 PSIG - W.O.R. 14100 SCFH

B. 20 PSIG - Set. 20800 SCFH

C. 40 PSIG - W.O.R. 32800 SCFH

INTERNAL MONITOR PRINCIPLE OF OPERATION

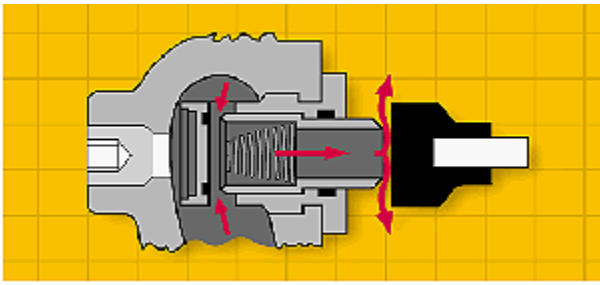

A. Standard regulator and upstream monitor orifice.

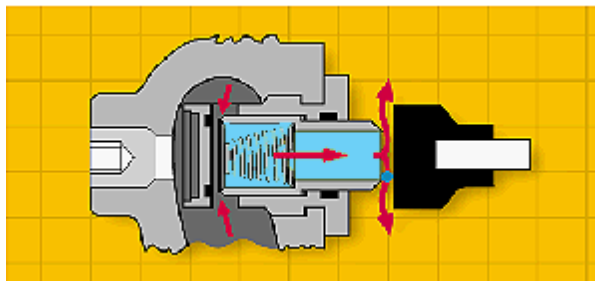

B. Standard regulator orifice failed; upstream monitor orifice control.

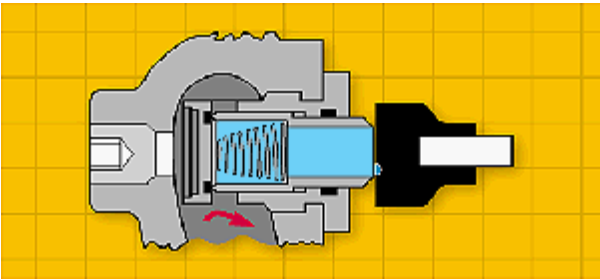

C. Main orifice failed; upstream monitor orifice lock-up.

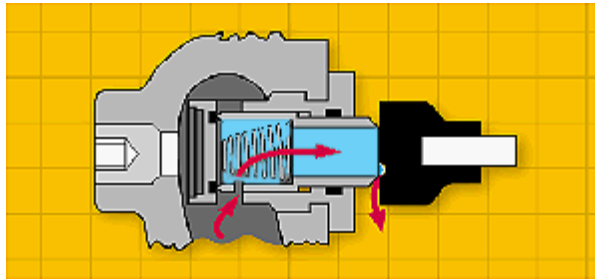

D. V option; vents a small volume of gas to atmosphere through relief valve.

 Inlet pressure  Outlet pressure

PRINCIPLE OF OPERATION

A. Normal operation. The internal monitor (IM) orifice performs like a standard regulator and monitor orifice, in that the monitor orifice is wide open under normal operation and the regulating orifice and valve seat position themselves to control outlet flow and pressure. The regulator is free to lock-up in the usual manner, with pressure increase to position the valve seat gas tight against the regulating orifice face. Both the monitor seat and the regulator seat may close together if the positive shock lock-up exceeds the monitor spring setting.

B. Monitor operation. If the regulator valve seat fails to control the gas flow and pressure due to foreign matter between the seat and orifice face, or if the seat is eroded, the internal monitor orifice automatically goes into operating position. Any time the pressure on the large main diaphragm exceeds the power of the fixed monitor spring and the adjusted pressure of the main spring, this increase in outlet pressure causes the valve seat to push against the sliding orifice, compressing the monitor spring and positioning the monitor orifice to control the gas flow and override outlet pressure.

The IM orifice now functions as a monitor regulator and will continue to monitor so long as the main seat fails to control at the normal adjusted outlet pressure. If the gas load demand is increased beyond the internal monitor's capacity, the outlet pressure is reduced to normal adjusted pressure and the regulator resumes normal operation.

C. Monitor lock-up. If the demand for gas is decreased to zero flow during monitor operation, the sliding orifice continues to close until its orifice is in the gas tight position (monitor lock-up) against the Buna-N monitor valve seat. (See the Internal Monitor Lock-up Pressure table for the outlet pressure required for internal monitor lock-up.)

D. Vent hole V option. On installations where a small volume of over-pressure gas can be safely vented to the atmosphere, the advantages of both the pilot relief valve and monitor safety can be combined. If the flow is decreased to zero or just greater than zero, the vent hole in the internal monitor orifice allows gas to slowly bleed downstream and cause the pressure to rise to the relief point of the pilot's internal relief valve. The gas then bleeds to the atmosphere indicating a problem with the regulator is reduced to normal adjusted pressure and the regulator resumes normal regulation.

INTERNAL MONITOR LOCK-UP PRESSURE

	Pilot Spring Color	Outlet Pressure Set Point	IM Lock-up Pressure
CL 38-1 IM	Blue/white	7" w.c.	24" w.c.
	Silver/white	11" w.c.	28" w.c.
	Silver/white	1 psig	1.6 psig
	Red/white	2 psig	2.6 psig
	Red/white	3 psig	3.7 psig
	White	5 psig	5.8 psig
CL 38-2 IM	Brown	1 psig	2.0 psig
	Green	2 psig	3.0 psig
	Green	3 psig	4.2 psig
	Green	5 psig	6.2 psig
	Green	8 psig	9.2 psig
	Black	10 psig	11.4 psig
	Blue	15 psig	16.6 psig
	Blue	20 psig	22.0 psig
	Blue	25 psig	28.0 psig
	Silver	30 psig	33.4 psig

CL38 IM PERFORMANCE CURVES

Type and model	CL38 IM
Inlet size:	2-inch NPT
Outlet size:	2-inch NPT
Orifice size:	3/4"

All test results are reported at a base of 14.7 PSIG at 60°F and with 0.6 S.G. gas.

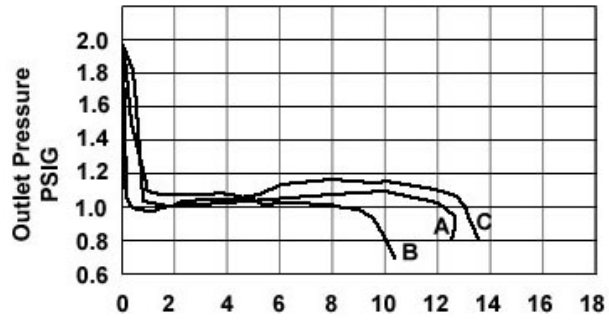

- A. Normal regulation
 - B. Failed with foreign particle
 - C. Failed with eroded valve seat
- Loading ring @ 0 degrees

CL38-IM SERIES CONSTANT LOADED REGULATOR CAPACITY TABLE

1% Absolute Droop

Capacities in SCFH of 0.6 S.G. gas; base conditions of 14.7 PSIA and 60° F.

Typical Capacity Info.

Manufacturer	ROOTS Regulators
Type and model	CL38 IM
Regulator	
Inlet size:	2 NPT
Outlet size:	2 NPT

Inlet Pressure PSIG	Outlet Pressure PSIG	Orifice Size				
		3/8"	1/2"	5/8"	3/4"	1"
		Orifice Constant Factor				
		290	425	615	720	875
Capacities in 1000 SCFH						
2	7" w.c.	1.4	1.95	3.1	3.65	4.55
	11" w.c.	1.35	1.9	3.0	3.5	4.4
	1 PSIG	1.1	1.55	2.5	2.9	3.65
	1.5 PSIG	0.85	1.2	1.9	2.2	2.8
3	7" w.c.	1.75	2.4	3.85	4.5	5.65
	11" w.c.	1.7	2.35	3.75	4.4	5.5
	1 PSIG	1.55	2.1	3.4	3.95	5.0
	2 PSIG	1.15	1.6	2.55	3.0	3.75
5	7" w.c.	2.25	3.15	5.0	5.85	7.35
	11 w.c.	2.25	3.1	4.95	5.8	7.25
	1 PSIG	2.15	2.95	4.7	5.5	6.95
	2 PSIG	1.9	2.65	4.25	4.95	6.25
	3 PSIG	1.65	2.25	3.6	4.25	5.3
10	7" w.c.	3.25	4.45	7.1	8.35	10.4
	11" w.c.	3.2	4.45	7.1	8.3	10.4
	1 PSIG	3.2	4.4	7.0	8.2	10.3
	2 PSIG	3.1	4.25	6.85	8.0	10.0
	5 PSIG	2.7	3.7	5.9	6.9	8.7
	8 PSIG	1.9	2.6	4.15	4.85	6.1
15	1 PSIG or less	3.95	5.45	9.05	10.5	12.9
	2 PSIG	3.95	5.45	9.0	10.4	12.8
	5 PSIG	3.75	5.2	8.6	10.0	12.2
	8 PSIG	3.4	4.7	7.7	9.0	11.0
	10 PSIG	3.0	4.15	6.9	8.0	9.8
	13 PSIG	2.1	2.9	4.8	5.6	6.85

Notes

K values are wide open per each orifice size.

Loading ring set at 0° for PSIG outlet pressures. Loading ring set at 25° for inches w.c. outlet pressures. Exact settings may vary with individual applications of pressures and load conditions.

*Set point at each outlet pressure was reached using 200 SCFH.

CL38-IM SERIES CONSTANT LOADED REGULATOR CAPACITY TABLE CONTINUED

1% Absolute Droop

Typical Capacity Info.

Manufacturer	ROOTS Regulators
Type and model	CL38 IM
Regulator	
Inlet size:	2 NPT
Outlet size:	2 NPT

Inlet Pressure PSIG	Outlet Pressure PSIG	Orifice Size				
		3/8"	1/2"	5/8"	3/4"	1"
		Orifice Constant Factor				
		290	425	615	720	875
		Capacities in 1000 SCFH				
20	3.5 PSIG or less	4.65	6.55	10.5	12.3	15.0
	5 PSIG	4.6	6.5	10.5	12.2	14.9
	10 PSIG	4.25	6.0	9.65	11.2	13.7
	15 PSIG	3.35	4.7	7.6	8.85	10.8
	18 PSIG	2.3	3.25	5.25	6.15	7.55
30	9 PSIG or less	6.0	8.9	13.6	15.8	19.4
	10 PSIG	5.95	8.9	13.5	15.7	19.3
	15 PSIG	5.7	8.45	12.9	15.0	18.4
	20 PSIG	5.05	7.5	11.5	13.3	16.4
	25 PSIG	3.9	5.8	8.85	10.3	12.6
40	14 PSIG or less	7.35	10.9	16.6	19.4	23.7
	15 PSIG	7.3	10.9	16.6	19.3	23.7
	20 PSIG	7.1	10.5	16.1	18.7	23.0
	30 PSIG	5.75	8.6	13.1	15.2	18.7
50	19.5 PSIG or less	8.7	12.9	19.7	22.9	28.1
	20 PSIG	8.65	12.9	19.6	22.9	28.0
	30 PSIG	8.05	12.0	18.3	21.3	26.1
60	24.5 PSIG or less	10.0	14.9	22.7	26.5	32.4
	25 PSIG	10.0	14.9	22.7	26.4	32.4
	30 PSIG	9.85	14.6	22.3	26.0	31.9
75	30 PSIG or less	12.0	17.9	27.3	31.8	39.0
100	30 PSIG or less	15.4	22.9	34.9	40.7	49.8
125	30 PSIG or less	18.7	27.9	42.6	49.5	

Notes

K values are wide open per each orifice size.

Loading ring set at 0° for PSIG outlet pressures. Loading ring set at 25° for inches w.c. outlet pressures. Exact settings may vary with individual applications of pressures and load conditions.

*Set point at each outlet pressure was reached using 200 SCFH.

Figures below heavy line may show differentials greater than allowable limits. Check closing spring tables.

Do not operate orifice in shaded inlet pressure area

ASSEMBLY POSITIONS

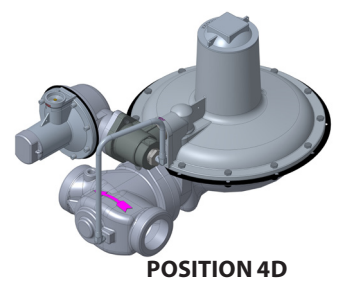
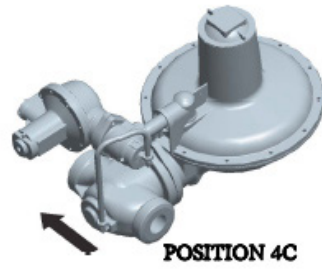
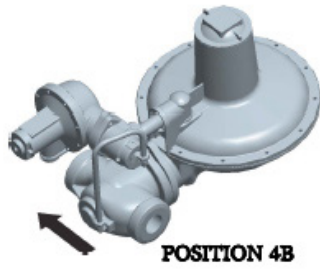
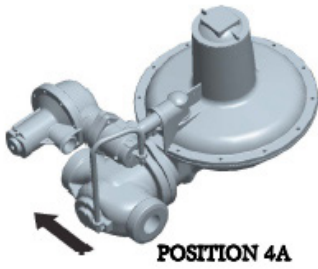
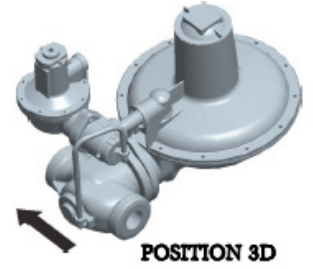
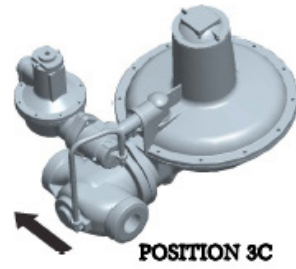
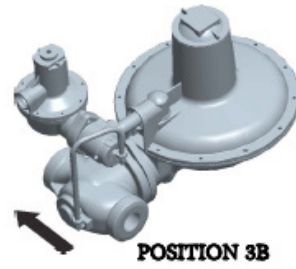
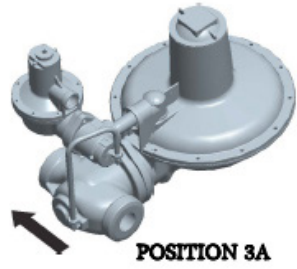
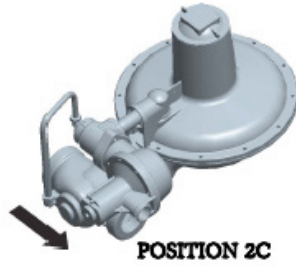
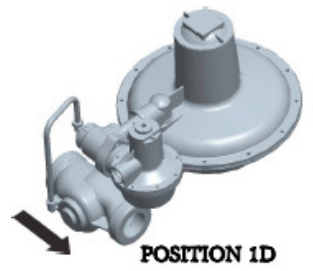
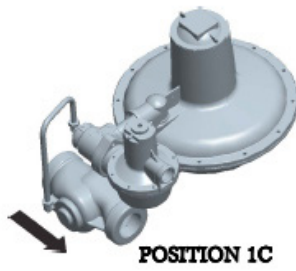
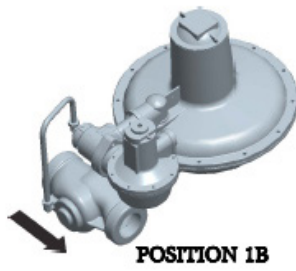
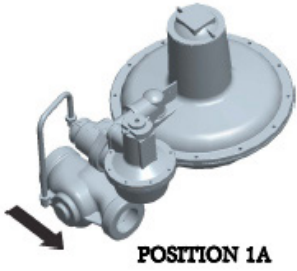

PARTS LIST

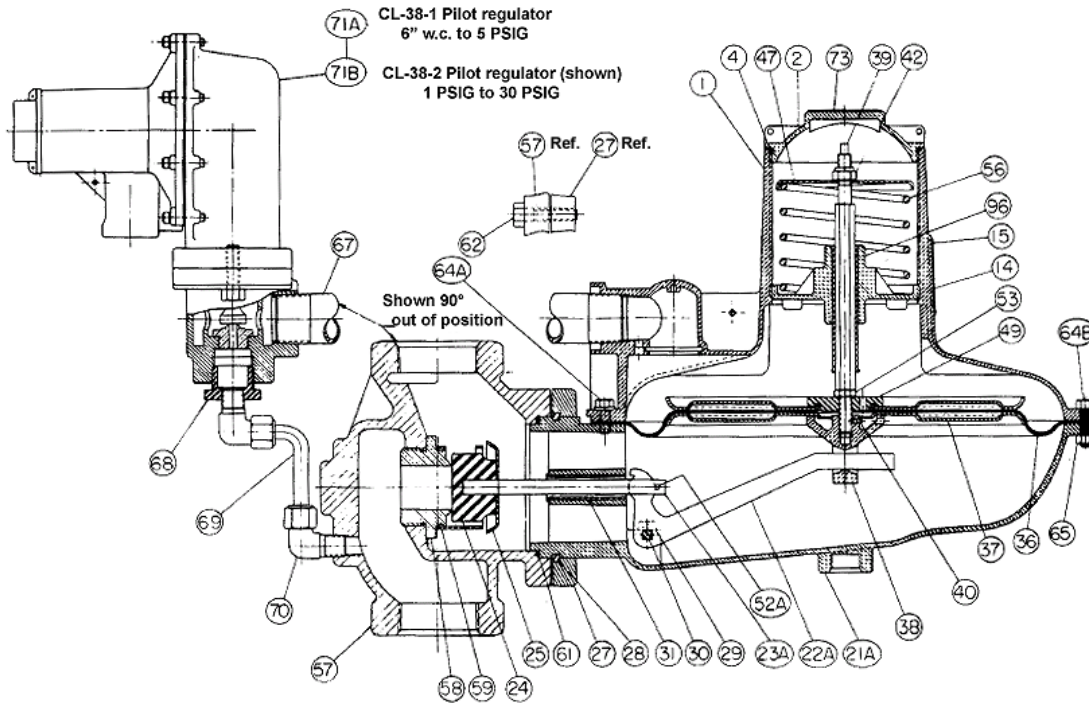

CL 38M and D

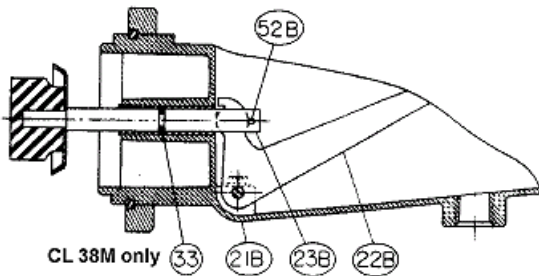

Item No.	Part No.	Quantity Required per Regulator Model		Description
		M	IM	
1	753418			Upper diaphragm case, vent 1" pipe
2	760084			Seal cap
3	736011			Adjustment screw guide assembly
4	765607			Seal cap gasket
14	769249			Regulator badge
15	755071			Badge drive screw
21A	715065PC			Lower diaphragm case, 4:1 ratio-open throat
21B	715066PC			Lower diaphragm case, 3:5:1 ratio-closed throat
22A	761275			Valve linkage lever, 4:1 ratio
22B	761271			Valve linkage lever, 3:5:1 ratio
23A	754191			Valve stem, 3/8" square

Item No.	Part No.	Quantity Required per Regulator Model		Description
		M	IM	
23B	754193			Valve stem, 17/32" diameter without ring groove
24	765211			Valve seat, Buna "N", 80 Duro
25	761731			Deflector
27	751933PC			Valve body retainer plate
28	755721			Retainer plate snap ring
29	755223			Valve linkage pin screw
30	754836			Valve linkage pin
33	765505			Valve Stem O-ring
36	766301			Diaphragm
37	76104102			Upper diaphragm plate
38	756077			Lower diaphragm plate
39	754361			Stop stem
40	755115			Set screw
42	755671			Stop stem lock nut
47	761471			Closing spring guide
49	761083			Secondary diaphragm plate
52A	755007			Valve stem slot pin, 3A2" D. x 2/8" Lg.
52B	755009			Valve stem slot pin, 2/32" D x 1/2" Lg.
53	755531			Diaphragm nut, steel
56				Closing spring, please specify:
	762341			Orange
	762351			Brown
	762353			Green
	762355			Black
	762365			Purple
57				Valve body, please specify type & size:
				Straight
	750829			1 1/2" x 1 1/2" NPT w 1/4" NPT
	750845			1 1/2" x 2" NPT with 1/4" NPT
	750860			2" x 2" NPT w 1/4" NPT
				Flanged
	750875			2" A.S.A. with 1/4" NPT
	750891			3" A.S.A. with 1/4" NPT
58A				Orifice, Brass - specify size:
				Straight
	758398			1/4" diameter
	758401			1/2" diameter
	758404			3/4" diameter
	758407			1" diameter
	758410			1-1/4" diameter
	758413			1-3/8" diameter
	758416			5/8" diameter
	758419			3/8" diameter
58B				
	759031			Orifice assembly 1" IM
	759033			Orifice assembly 1" IM vented
	759035			Orifice assembly 5/8" IM
	759037			Orifice assembly 5/8" IM vented
	759038			Orifice assembly 3/4" IM
	759039			Orifice assembly 3/4" IM vented

Item No.	Part No.	Quantity Required per Regulator Model		Description
		M	IM	
	759041			Orifice assembly 3/8" IM
	759043			Orifice assembly 3/8" IM vented
	759045			Orifice assembly 1/2" IM
	759047			Orifice assembly 1/2" IM vented
59	761771			Loading ring
61	80001901			Valve body gasket
62	755391-001			Retainer plate screw - hex head steel
64	755311-001			Case screw hex head - 1A - 20x1" Lg.
65	755513-001			Case screw nut
67	768143			Nipple, 1" NPT x 2" Lg.
68	768203			Reducing bushing, 3/4" x 1"
69	768523			Pilot supply line, stainless steel
70	768263			90° Elbow - male tube fitting, 3/4" D" Tubex 1/4" NPTF, steel
71A	700101			CL38-1 Pilot green/white
71A	700102			CL38-1 Pilot blue/white
71A	700103			CL38-1 Pilot dark green
71A	700104			CL38-1 Pilot silver/white
71A	700105			CL38-1 Pilot yellow/white
71A	700106			CL38-1 Pilot red/white
71A	700107			CL38-1 Pilot white
71A	700108			CL38-1 Pilot silver (B31)
71B	700201			CL38-2 Pilot brown
71B	700214			CL38-2 Pilot Gr Adj/Gr relief
71B	700202			CL38-2 Pilot green
71B	700203			CL38-2 Pilot black
71B	700204			CL38-2 Pilot blue
71B	700215			CL38-2 Pilot silver
71B	700200-6			CL38-2 Pilot green/white

CL38-1 PILOT PARTS LIST

(see main parts list for pilot assembly part numbers)

Item No.	Part No.	Quantity	Description
		CL38-1 RI	
1	753027PC	1	Upper diaphragm case, 3/4" vent
2	760053	1	Seal cap
3	760217	1	Adjustment screw, aluminum
4	765503	1	Seal cap gasket
5	762935	1	Vent screen, wire mesh
6	75572701	1	Vent screen retaining ring
7	754806	1	Vent screen disc pin
8	762601	1	Vent valve spring
9	765181	1	Vent valve disc
10	765685	1	Vent valve seat
21	752311PC	1	Lower diaphragm case
22	761201		Valve linkage lever
23	754021	1	Valve stem, aluminum
24	765021	1	Valve seat, Buna "N", 75 Duro
27	751913PC	1	Valve body retainer plate
28	755725	1	Retainer plate snap ring
29	755141	2	Valve linkage pin screw

Item No.	Part No.	Quantity	Description
		CL38-1 RI	
30	754831	1	Valve linkage pin
38	766010	1	Diaphragm
37	761001	1	Upper diaphragm plate
38	756021	1	Lower diaphragm plate
41	761401	1	Relief spring guide
43	762051	1	Relief spring 14" w.c. above set
44	754905	1	Stop stem guide bushing
50	765755	1	Relief valve seal gasket
56		1	Adjustment spring, please specify:
	762007		Green/white
	762013		Blue/white
	762117		Dark green
	762017		Silver/white
	762021		Yellow/white
	762027		Red/white
	762029		White
	762034		Yellow/blue
	762650		Yellow/black
57	750044PC	1	90" Valve body ¾x 1"
58	757255	1	Orifice, 1/8" diameter, brass
59	761753	1	Loading ring
61	765753	1	Valve body gasket, flat
62	755371	2	Retainer plate screw, hex-head steel, 5/16" – 18 x 1-1/8" length, cad. plate
64	755221	8	Case screw - hex washer head steel #8-32 x 13/16" Lg., cad. plate

CL38-2 PILOT PARTS LIST

(see main parts list for pilot assembly part numbers)

Item No.	Part No.	Quantity	Description
1	753044PC	1	Upper diaphragm case, 3/4" vent
2	730003	1	Seal cap assembly
3	760201	1	Adjustment screw
4	765603	1	Seal cap gasket
5	762905	1	Vent screen, spiral
6	75572701	1	Vent screen retaining ring
19	730101	1	Vent valve assembly
21	752311PC	1	Lower diaphragm case
22	761201	1	Valve linkage lever
23	754021	1	Valve stem
24	765021	1	Valve Seat, Buna "N", 75 Duro
27	751955	1	Valve body retainer plate
28	755725	1	Retainer plate snap ring
29	755141	2	Valve linkage pin screw
30	754832	1	Valve linkage pin
36	766031	1	Diaphragm
37	761011	1	Upper diaphragm plate
38	756001	1	Lower diaphragm plate
39	755191	1	Stop stem, steel
41	761411	1	Relief spring guide
43	762081	1	Relief spring, brown 1.5 PSIG above set

Item No.	Part No.	Quantity	Description
47	761421	1	Adjustment spring guide
50	765711	1	Relief valve seal gasket
51	756005	1	Diaphragm plate screw
52	755001	1	Roll pin
56		1	Adjustment spring, please specify
	762401		Brown
	762403		Green
	762405		Black
	762407		Blue
	762409		Silver
57	750044PC	1	90° Valve body ¾» x 1"
58	757255	1	Orifice 1/8" diameter, brass
59	761753	1	Loading ring
61	765753	1	Valve body gasket
62	755371	2	Retainer plate screw hex head steel, 5/16-18 x 1-1/8" Lg. cad. plate
64	755175	8	Case screw, soc. Head, #10-24 x 7/8" Lg. steel cad. plate
66	755855	8	Lock washer
67	755821	1	Washer, anti-friction

ORIFICE CARTRIDGE ASSEMBLY

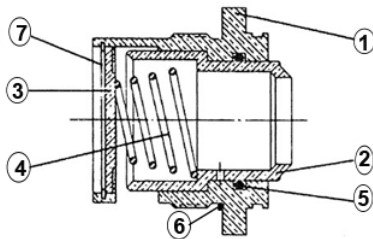

759041 3/8" and 759045 1/2" cartridge orifice components sub-assembly (are interchangeable with each other).

Designator	Part No.	Description
1	758307	Stationary orifice
2	758357	3/8" Sliding orifice
2	758351	1/2" Sliding orifice
3	759025	Orifice plate
4	762683	Cut-off spring (red)
5	765531	O-ring
6	765525	O-ring
7	755737	Retaining ring

759035 5/8" and 759038 3/4" cartridge orifice components sub-assembly (are interchangeable with each other).

Designator	Part No.	Description
1	758304	Stationary orifice
2	758357	5/8" Sliding orifice
2	758321	3/4" Sliding orifice
3	759023	Orifice plate
4	762681	Cut-off spring (blue)
5	765533	O-ring
6	765525	O-ring
7	755737	Retaining ring

759031 1" cartridge orifice components sub-assembly (not interchangeable with other sizes).

Designator	Part No.	Description
1	758301	Stationary orifice
2	758311	1" Sliding orifice
3	759023	Orifice plate
4	762685	Cut-off spring (black)
5	765523	O-ring
6	765525	O-ring
7	755737	Retaining ring

VENT LINES FOR REGULATORS

If you are constructing vent lines to be attached to regulators installed indoors, follow a few basic rules:

- Never use pipe sizes smaller than the vent size; smaller pipe sizes restrict the gas flow. If a long gas run must be used, ROOTS Regulators advises increasing the pipe one nominal size every ten feet to keep the flow restriction as low as possible.
- Keep the vent line length as short as possible to minimize the restriction and reduce the vent's tendency to cause regulator pulsation.
- Support the vent pipe to eliminate strain on the regulator diaphragm case.
- Always point outdoor vent pipes in the downward position to reduce the possibility of rain, snow, sleet, and other moisture entering the pipe. Install a bug screen in the end of the pipe.
- Do not locate the vent line terminus near windows, fans, or other ventilation equipment. See the installation instructions furnished with the regulator.
- Adhere to all applicable codes and regulations.
- If your vent pipe causes regulator pulsation, consult your sales representative or manufacturer.
- ROOTS Regulators strongly recommends running a separate vent line for each regulator. Headers with various installed devices can cause regulator malfunction.

Caution Ensure the end of the vent line is away from ANY potential ignition sources. It is the installer's responsibility to verify the vent line is exhausting to a safe environment.

INSTALLATION

Warning ROOTS Regulators does not endorse or warrant the completeness or accuracy of any third party regulator installation procedures or practices, unless otherwise provided in writing by ROOTS Regulators. Follow your company's standard operating procedures regarding the use of personal protection equipment (PPE). Adhere to guidelines issued by your company in addition to those given in this document when regulators are installed.

- Remove all shipping plugs from the regulator inlet, outlet, and vent before installation.
- Verify the piping interior and regulator inlet and outlet are clean and free of dirt, pipe dope, and other debris. Dirt and other foreign materials entering the regulator can cause a loss of pressure control.
- Apply pipe joint sealant to the male pipe threads. Do not use pipe joint material on the regulator's female threads. Joint sealant could become lodged in the regulator and cause a loss of pressure control.
- Gas must flow through the regulator's valve body in the direction cast on the regulator body. Gas flowing in the wrong direction can overpressure and cause damage to the regulator.
- The pilot diaphragm casing can be mounted in any position relative to the body through a full 360° angle at 90° increments.
- When the regulator is installed OUTDOORS, the vent must always be positioned so that rain, snow, moisture or foreign particles cannot enter the vent opening. ROOTS Regulators recommends positioning the pilot vent downward to avoid entry of water or other matter which could interfere with the proper operation of the regulator. The vent should be located away from building eaves, window openings, building air intakes and above the expected snow level at the site. The vent opening should be inspected periodically to insure it does not become blocked by foreign material as outlined in DOT PHMSA-RSPA-2004-19856.
- When the regulator is installed INDOORS, the vent must be piped to the outside atmosphere using the shortest length of pipe, the fewest possible pipe elbows, and a pipe diameter as large as the vent size or larger. USING VENT PIPE SMALLER THAN THE VENT CONNECTION LIMITS THE REGULATOR'S INTERNAL RELIEF VALVE CAPACITY. The outlet end of the pipe must be protected from moisture and the entrance of foreign particles. The regulator should be specified by the user with the size vent and pipe threads desired to make the vent pipe connection.

START-UP PROCEDURE

- a. Mount a pressure gauge downstream of the regulator to monitor the downstream pressure.
- b. With the downstream pressure valve closed, slowly open the inlet valve. The outlet pressure should rise to slightly more than the set-point. Verify there are no leaks and all connections are tight.
- c. The regulator was pre-set at the factory to match order specifications. If necessary, adjust the outlet pressure by removing the seal cap on the top of the pilot spring housing and adjusting the ferrule or screw inside the pilot spring housing using a large flat-head screwdriver. Do not remove the seal cap from the main regulator unless all gas is shut off and all pressure is released from the regulator. Failure to shut off gas and release pressure from the regulator will allow pressurized gas to escape from the regulator. With a small amount of gas flowing through the regulator, rotate the pilot ferrule clockwise to raise the outlet pressure or counter-clockwise to lower the outlet pressure.
- d. Replace the seal cap and check for leaks after the desired outlet pressure is achieved.

The regulator is ready for operation.

Notes:

- a. The maximum inlet pressure for this regulator is dependent upon the size of the orifice and model designation. The non-relief models are limited to 60 pounds per square inch gauge maximum inlet pressure unless additional safeguards are used as outlined in the DOT code, OPS, Part 192, section 192.197.
- b. This regulator should not be used for temperatures exceeding 150° F.
- c. When these models are used on liquid petroleum gases, they should be restricted to secondary control purposes and can only be used for second stage pressure reduction in the gaseous phase.
- d. Contact ROOTS Regulators, Houston, TX with customer inquiries about the selection, application, and recommended instructions for gas service regulators.

SAFETY WARNING

This product, as of the date of manufacture, is designed and tested to conform to all governmental and industry safety standards as they may apply to the manufacturer. The purchaser/user of this product must comply with all fire control, building codes, and other safety regulations governing the application, installation, operation, and general use of this regulator to avoid leaking gas hazards resulting from improper installation, startup or use of this product.

ROOTS Regulators strongly recommends installation by a qualified professional and periodic inspection of pressure regulators (inspections may be required by local applicable codes or regulations).

Inspections should include checking for gas quality, cycle numbers, external environmental changes, and operating conditions that impact wear on the regulator's moving parts. To ensure safe and efficient operation of this product, replace worn or damaged parts found during inspection.

Limited Warranty

ROOTS Regulators are subject to the terms and conditions of the Natural Gas Solutions North America, LLC General Terms & Conditions For Sale of Products, Parts and Services, and no other terms shall apply, unless agreed upon by the parties in writing. The Natural Gas Solutions North America, LLC General Terms & Conditions For Sale of Products, Parts and Services can be found on the Dresser Utility website: dresserutility.com/forms-questionnaires-and-terms-conditions-sale.

Ordering Information

1. Inlet and outlet connection size and type
2. Model number
3. Outlet pressure desired
4. Inlet pressure range
5. Type of gas and maximum capacity required
6. Assembly position number (see diagram above)
7. Vent size
8. Special requirements such as tagging, pipe plug tap, seal wire, etc.

ROOTS Regulator + ROOTS Meter Compatibility

<u>Small</u>	<u>Regular</u>	<u>Large</u>
102M125	23M-56M	102M125

ROOTS Regulators

16240 Port Northwest Drive

Houston, TX 77041

T: 1-800-521-1114

F: 1-800-335-5224

© 2025 Natural Gas Solutions North America, LLC – All rights reserved. Dresser Utility Solutions reserves the right to make changes in specifications and features shown herein, or discontinue the product described at any time without notice or obligation. Contact your Dresser Utility Solutions representative for the most current information. The Dresser Logo and all Trademarks containing the term "Dresser" are the property of Dresser, LLC, a subsidiary of Baker Hughes.

