

This document provides installation and start-up instructions for ROOTS Regulator models B42, B57, B58, B31, B34S, B34, B38, B35, B36, B56.



**Warning** Follow your company's standard operating procedures regarding the use of personal protection equipment (PPE). Adhere to guidelines issued by your company in addition to those contained in this document when installing or repairing natural gas regulators.



**Warning** This product, as of the date of manufacture, is designed and tested to conform to all governmental and industry safety standards as they may apply to the manufacturer. The purchaser/user of this product must comply with all fire control, building codes, and other safety regulations governing the application, installation, operation, and general use of this regulator to avoid leaking gas hazards resulting from improper installation, startup or use of this product.

To ensure safe and efficient operation of this product, Dresser Utility Solutions strongly recommends installation by a qualified professional.

### Safety Notes:

- **B-series regulator's maximum inlet pressure is dependent upon the orifice size and model designation.**
  - **Non-relief models are limited to 60 psig maximum inlet pressure unless additional safety devices are used as outlined in the DOT code: OPS, Part 192, Section 192.197.**
- **B-series regulators used on liquid petroleum gases should be restricted to second-stage pressure reduction in the gaseous phase.**
- **If the diaphragm case of the B57 regulator is loosened from the valve body using the union nut, the torque specification for tightening the union nut is 35 to 50 ft.-lbs. Tighten the union nut to the correct torque specification anytime the nut is loosened.**

### Installation



#### Caution

All Roots regulators should not be subjected to temperatures above 150 degrees which could damage the internal components of the regulator.

Remove all shipping plugs from the inlet, outlet, and vent of any ROOTS Regulator before installation.

Keep the piping interior (inner diameter), ROOTS Regulator inlet, and regulator outlet free of dirt, chemical sealant (pipe dope), Teflon tape, or other debris. Materials in piping or ROOTS Regulator inlet or outlet creating a loss of pressure control.

Gas must flow through the ROOTS Regulator valve body in the same direction as the arrow on the regulator body. Gas flowing in the wrong direction may cause an over-pressure condition and damage the ROOTS Regulator.

**Apply a gas resistant pipe joint sealant on the male (exterior) pipe threads. Do not use any type of Teflon tape on ROOTS Regulator installations. Do not apply pipe joint sealant on the female (interior) pipe threads of the ROOTS Regulator as joint materials could lodge in the regulator creating a loss of pressure control.**

**During product installation, do not clamp the valve body in a vice, this may lead to permanent damage rendering a ROOTS Regulator that is not fit for service.**

During product installation, use of excessive force and unsafe practices can lead to permanent damage rendering a ROOTS Regulator that is not fit for service. It is recommended to not exceed 3 full turns past hand tight into the ROOTS Regulator valve body per SAE standard AS71051. Do not use oversized pipe wrenches and/or "Cheater" bars during the installation of ROOTS Regulators which can damage valve body from an over torque situation.



**Note** The diaphragm casing may be mounted in any position (through a full 360° angle) relative to the regulator body.

### Outdoor Installation

When installing B-series regulators outdoors:

- Always position the regulator vent so moisture (rain, snow) or foreign particles cannot enter the vent opening.
- Dresser Utility Solutions recommends positioning the vent downward to avoid the entry of moisture or foreign materials into the vent.
- Locate the vent away from building eaves, window openings, or building air intakes.
- If applicable, mount the regulator vent above the site's expected snow level.



**Warning** Schedule periodic inspections to check the regulator vent for foreign materials as outlined in DOT PHMSA-RSPA-2004-19856.

### Indoor Installation

When installing B-series regulators indoors, pipe the vent to outside atmosphere using:

- The shortest pipe length
- The fewest possible pipe elbows
- A pipe diameter as equal to the vent size (or larger)



**Warning** Using a vent pipe smaller than the vent connection will limit the regulator's internal relief valve capacity. Protect the pipe's outlet end from moisture and the entry of foreign materials. Specify the correct vent size and pipe threads to make the regulator's vent pipe connection.

### Start-up Procedure (all models)

#### *To start-up the B-series regulator*

1. Mount a pressure gauge downstream of the regulator to monitor the downstream pressure
2. With the downstream pressure valve closed, slowly open the inlet valve. The outlet pressure should rise to slightly more than the set-point.

---

**Note** For B31 RAS models, remove the seal cap and pull up on the spring housing stem to reset the shut-off valve. Release the stem. This procedure allows gas to flow through the regulator. Downstream pressure should rise to the regulator's set-point.

---

3. Verify there are no leaks and all connections are tight.

- The regulator was pre-set at the factory to match order specifications. If necessary, adjust the outlet pressure by removing the seal cap on the top of the spring housing and rotating the adjustment screw inside the spring housing.

---

**Note** Adjusting the outlet pressure requires:

- Models B42, B57, B58, B31, B35, B56, and B36: large flat-head screwdriver
- Models B34 and B38: 9/16" socket and ratchet
- Model RB4000: adjustment wrench (ROOTS part number 799056)

- 
- With a small amount of gas flowing through the regulator:
    - rotate the adjustment screw clockwise to raise the outlet pressure
    - rotate the adjustment screw counterclockwise to lower the outlet pressure.
  - Replace the seal cap and check for leaks after the desired outlet pressure is achieved. The regulator is ready for operation.

### OPCO Start Up Procedure

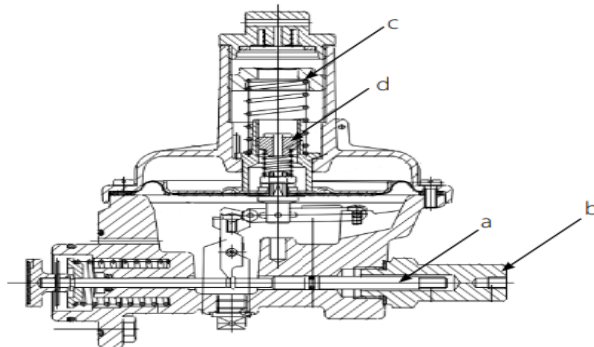

Commissioning SSV1 OPCO - Unscrew the cap (b) and screw it onto the valve rod (a). Slowly pull out the valve rod until the output pressure in the control unit is established, the lever system of the SAV engages and the valve rod remains open. **Only possible if the outlet pressure in the main regulator is less than opco set point!** Then screw the cap (b) back on.

### ROOTS Regulators

16240 Port Northwest Drive

Houston, TX 77041

T: 1-800-521-1114

F: 1-800-335-5224

© 2024 Natural Gas Solutions North America, LLC – All rights reserved. Dresser Utility Solutions reserves the right to make changes in specifications and features shown herein, or discontinue the product described at any time without notice or obligation. Contact your Dresser Utility Solutions representative for the most current information. The Dresser Logo and all Trademarks containing the term "Dresser" are the property of Dresser, LLC, a subsidiary of Baker Hughes.



[www.dresserutility.com](http://www.dresserutility.com)

ROOTS Regulators B Series Installation DUS.ROOTS.030b  
TDC-0851-003 for the B Series Installation  
09.25