

Pipe Joining Products for Water, Wastewater and Industrial Piping Systems

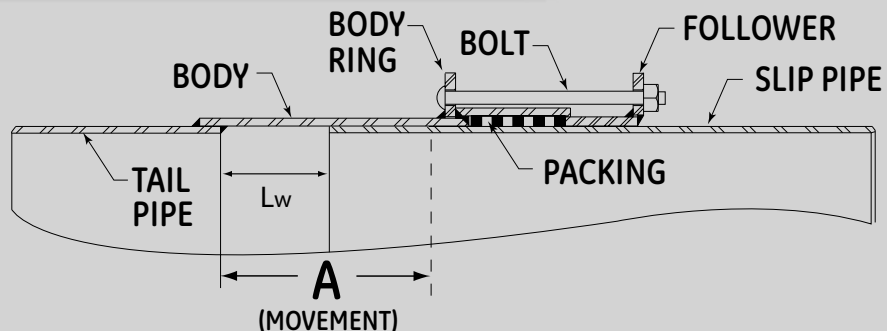

- Couplings
- Line Caps
- Flange Adapters
- Dismantling Joints
- Expansion Joints
- Joint Harnesses
- Custom Fabrication



Why DRESSER™ bolted couplings are used more than any other coupling...

- Dresser offers the broadest line of couplings, including long-body, insulating, reducing and transition types.
- Dresser couplings are fast and easy to install with any size pipe or tubing.
- Dresser couplings create flexible, non-rigid pipeline joints accepting expansion, contraction, vibration and line deflection.
- Sizes range from 1/2" through 120" to cover every application including high temperature or severe and abrasive line contents. Larger diameter Penstock sizes available upon request.
- Wide temperature range from -20°F to +1200°F, with pressure ratings up to 1500 PSI.
- Special gasket elastomer formulations are provided custom-matched to specific fluid process or application requirements.
- Products feature Dresser ALCLAD™ epoxy coating as standard in the most popular sizes. Our epoxy coating offers optimum protection against highly corrosive soil or aggressive water conditions and for handling brine, brackish water, most acids, alkalis, oil, chemical particulates and gases.
- Available in rugged welded carbon steel construction. Also available in all stainless steel in 304 and 316 for special applications.
- Select water products are now NSF61 and 372 certified.

Cutaway view shows components of a basic Dresser Style 38 Coupling

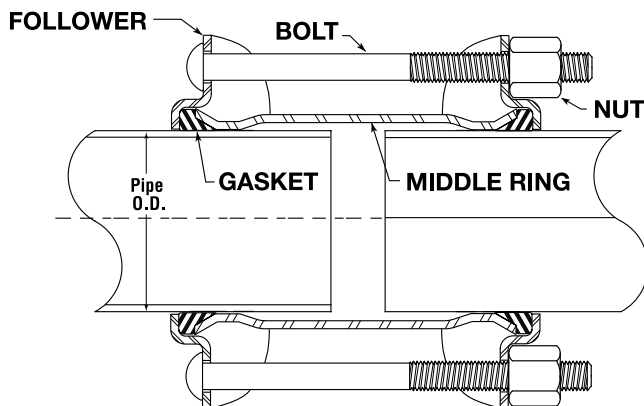

The Basic Working Principle of Dresser Couplings...

The DRESSER coupling consists of one cylindrical middle ring, two follower rings, two resilient gaskets of special Dresser compound, and a set of steel trackhead bolts. The middle ring has a conical flare at each end to receive the wedge portion of the gaskets. The follower rings confine the outer ends of the gaskets. As the nuts are tightened, the bolts draw the follower rings toward each other, compressing the gaskets in the spaces formed by follower rings, middle ring flares and pipe surface thus producing a flexible, leak-proof seal on the pipe joint.

Style 38,
38 Stainless
& 138 Couplings

Page 5-7

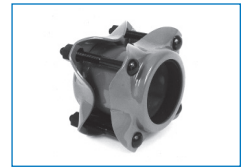

Style 40
Long Coupling

Page 8



Style 62 Reducing
& Transition
Couplings

Page 9-10



Style 167
Lock Coupling

Page 11



Style 128
Flange Adapter

Page 12



Style 131
Dismantling
Joint

Page 13



Style 63
Expansion
Joint

Page 15

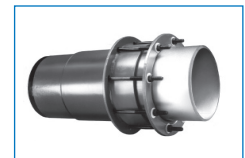

Style 440
Joint
Harness

Page 16

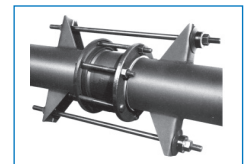

Style 39
Line Cap

Page 17



Dresser Gasket Overview.....Page 18

How to Specify Dresser Products

For those who may wish to draw up specifications of a general nature covering Dresser bolted couplings, this suggested form is offered:

1.) The pipe coupling shall be of a gasketed, sleeve-type design with diameter to properly fit the pipe. Each coupling shall consist of one (1) steel middle ring, of thickness and length specified, two (2) steel followers, two (2) rubber-compounded wedge section gaskets and sufficient trackhead steel bolts to properly compress the gaskets.

The middle ring and followers of the coupling shall be true circular sections free from irregularities, flat spots or surface defects. They shall be formed from mill sections with the follower-ring section of such design as to provide confinement of the gasket. After welding, they shall be tested by cold expanding a minimum of 1% beyond the yield point. The middle ring, inside and out, and followers shall be coated with ALCLAD™ thermosetting, fusion-bonded epoxy coating material that provides disbondment resistance in cathodically-protected systems and resistance to soil stresses and fungi. All constituents of the cured film are FDA and NSF-61 approved for exposure to fluids for human consumption and potable water.

The coupling bolts shall be of the elliptic-neck, trackhead design with rolled threads. The manufacturer shall supply information as to the recommended torque to which the bolts shall be tightened. All bolt holes in the followers shall be oval for greater strength.

The coupling gaskets shall be composed of a crude or synthetic rubber base compounded with other products to produce a material that will not deteriorate from age, heat, or exposure to air under normal storage conditions. It shall also possess the quality of resilience and ability to resist cold flow of the material so that the joint will remain sealed and tight indefinitely when subjected to shock, vibration, pulsation and temperature or other adjustments of the pipeline.

2.) The couplings shall be assembled on the job in a manner to ensure permanently tight joints under all reasonable conditions of expansion, contraction, shifting and settlement, unavoidable variations in trench gradient, etc. The coupling shall be Dresser Style 38, as manufactured by Dresser Pipeline Solutions, Bradford, PA, and the necessary quantity shall be furnished.

When Ordering Dresser Expansion Joints

Inquiries or orders for Dresser Style 63 Expansion Joints should contain the following information:

- (1) Quantity
- (2) Type of pipe: Steel, cast or ductile iron, etc.
- (3) Style Number and Type 1 or Type 3
- (4) Service: Water, Industrial, etc.
- (5) Maximum working pressure required
- (6) Amount of movement to be taken care of by each joint
- (7) Temperature limitations and ranges
- (8) Frequency of cycling;
- (9) End preparation of slip or tail pipe—beveled for welding, flanged, other
- (10) Remarks, unusual installations, and list support methods of line and joint

The proper type of expansion joint to use and the method of anchoring and connecting it into a line depend upon the conditions of service and type of installation, as well as other joints in the line. The most effective use of Style 63 expansion joints usually requires an engineering recommendation. For that reason, a complete description of the installation should be submitted, with sketches or working drawings, if possible. Special joints may also be made for unusual conditions.

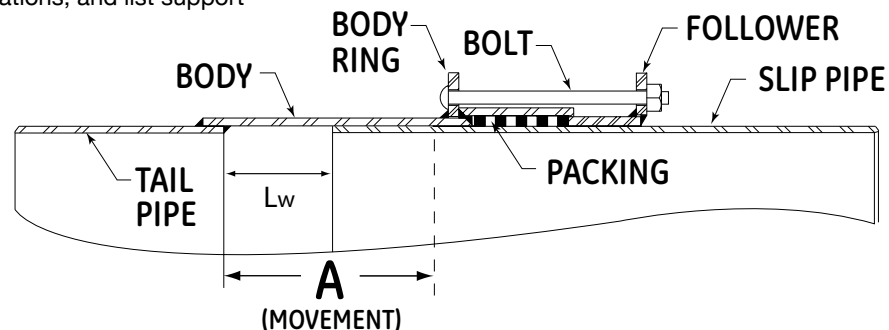

How to Specify Pipe Ends for Dresser Couplings

How to Specify Ends* on Steel Pipe

On orders and in specifications, the ends on steel pipe to be used with Dresser couplings may be specified briefly as follows:

- The pipe shall be furnished with plain ends for Dresser couplings in accordance with AWWA (American Water Works Association) Steel Water Pipe Specifications;
- OR:
- The pipe shall be furnished with plain ends for Dresser couplings in accordance with API (American Petroleum Institute) Line Pipe Specifications.

If specifications are to be detailed, the following may be used:

For Pipe Above 5" OD to 10-3/4" OD inclusive:

- The pipe shall be sufficiently free from indentations, projections or roll marks for a distance of 8" from the end of the pipe to make a tight joint with the rubber-gasket type of coupling. The outside diameter of the pipe shall not be more than 1/64" smaller than the nominal outside diameter for a distance of 8" from the end of the pipe and shall permit the passing for a distance of 8" of a ring gauge which has a bore 1/16" larger than the nominal outside diameter of the pipe. The minimum outside pipe diameter shall be determined by the use of a steel tape applied circumferentially to prevent the shipment of undersized, out-of-round pipe which, if measured diametrically through the maximum diameter or checked with a No-Go ring gauge, might appear within the specified tolerance.

For Pipe Larger than 10-3/4" OD:

- The pipe shall be sufficiently free from indentations, projections or roll marks for a distance of 8" from the end of the pipe to make a tight joint with the rubber-gasket type of coupling. The outside diameter of the pipe shall not be more than 1/32" smaller than the nominal outside diameter for a distance of 8" from the end of the pipe and shall permit the passing for a distance of 8" of a ring gauge which has a bore 3/32" larger than the nominal outside diameter of the pipe. The minimum outside pipe diameter shall be determined by the use of a steel tape circumferentially applied to prevent the shipment of undersized, out-of-round pipe which, if measured diametrically through the maximum diameter or checked with a No-Go ring gauge, might appear within the specified tolerance.

*While Dresser couplings require only plain-end pipe, other kinds of pipe ends (such as threaded, beveled or grooved) can be used if such pipe is already on hand.

How to Specify Ends on Cast/Ductile Iron Pipe

On orders and in specifications, the ends on cast or ductile iron pipe to be used with Dresser couplings may be specified briefly as follows:

- The pipe shall be furnished with plain ends for Dresser couplings in accordance with AWWA (American Water Works Association) specifications on tolerances;
- OR:
- The pipe shall be furnished with plain ends for Dresser couplings in accordance with AGA (American Gas Association) specifications on tolerances.

If further specifications are desired, the following may be added:

- The pipe shall be smooth and round for a distance of 8" from each end. The maximum plus or minus variation from nominal outside diameters for each size shall not exceed dimensions as shown in chart shown below.
- The maximum outside pipe diameter shall be such as to permit the passing of a ring gauge having an internal bore not greater than .01" larger than the maximum allowable outside diameter of the pipe. This ring gauge shall go over the end of the pipe for a distance of 8" for all sizes up to and including 24" and for a distance of 12" on sizes above 24".
- The minimum outside diameter shall be determined by use of a steel tape circumferentially applied to prevent the shipment of undersized, out-of-round pipe which, if measured diametrically through the maximum diameter or checked with a No-Go ring gauge, might appear within the specified tolerance.

PIPE SIZE (IN)	MAXIMUM VARIATION
3 - 16"	.06"
18 - 24"	.08"
30 - 42"	.10"
48"	.12"
54 - 60"	.15"

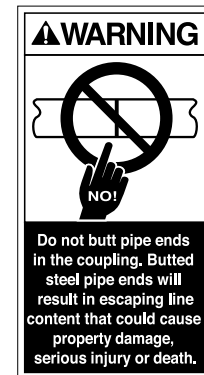

Standard Style 38 Coupling Pipe End Spacing

MIDDLE RING WIDTH	MIN PIPE END STAB	MAX PIPE END SPACING
5"	1"	1-1/2"
7"	1-1/4"	2"
10"	2-1/4"	3"

Coupling Deflection, Movement, Expansion and Contraction

Laying out curves with standard Dresser couplings and straight sections of pipe

Presented in tabular form in the table at right entitled "Radius of Curve and Deflection of Pipe in Feet", this chart indicates (1) radius of circle for any given degrees of deflection and pipe length, (2) length of pipe for any given radius and deflection or (3) degrees deflection necessary for any given pipe length and radius. This information is worked out for the more commonly used pipe lengths and degrees deflection.

RADIUS OF CURVE AND DEFLECTION OF PIPE IN FEET												
Length of Pipe Sec. (Ft.)	Radius of Curve (Feet)						Deflection of Pipe (Feet/Inches)					
	Varying degrees deflection in each coupling						Varying degrees deflection in each coupling					
	1°	2°	3°	4°	5°	6°	1°	2°	3°	4°	5°	6°
6	344	172	115	84	66	57	1/4"	2-1/2"	3-3/4"	5"	6-1/4"	7-1/2"
12	687	344	229	172	138	114	2-1/2"	5"	7-1/2"	10"	1' 5/8"	1' 3"
16	916	458	306	229	183	153	3-3/8"	6-3/4"	10"	1' 1-1/2"	1' 4-3/4"	1' 8"
18	1031	516	344	258	206	172	3-3/8"	7-1/2"	1' 1-1/4"	1' 3-1/8"	1' 6-7/8"	1' 10-1/2"
20	1145	573	382	286	229	191	4-1/4"	8-3/8"	1' 5/8"	1' 4-3/4"	1' 8-7/8"	2' 1"
30	1718	860	573	430	344	286	6-1/4"	1' 5/8"	1' 6-7/8"	2' 1"	2' 7-7/8"	3' 1-5/8"
40	2291	1146	764	573	458	382	8-3/8"	1' 4-3/4"	2' 1"	2' 9-1/2"	3' 5-7/8"	4' 2-1/8"

Expansion & Contraction

Dresser bolted couplings 10.75 OD and larger will safely accommodate up to 3/8" longitudinal pipe movement. This is equivalent to the amount of movement resulting from a 120° temperature variation in a 40-foot length of steel pipe. If pipe is not buried, anchorage should be provided to prevent excessive accumulation of movement. For repeated movements such as on a bridge or above ground, or if expansion exceeds 3/8" per joint, a Dresser Style 63 expansion joint should be used.

NOTE: Allowable axial movement for smaller pipe sizes 3/4" thru 2" OD is 1/8", and 1/4" for sizes 2-1/2" up to 10" OD.

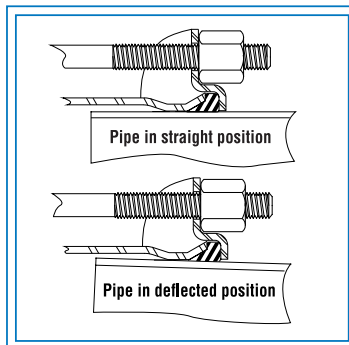

Maximum Recommended Laying Deflection Dresser Style 38 Couplings			
From 3/8" ID to 2" ID Inclusive.....6°			
From 2" ID to 14" OD Inclusive.....4°			
With Middle Ring Lengths:	5"	7"	10"
14" OD - 20" OD Inclusive	2-1/2°	4°	4°
20" OD - 30" OD Inclusive	2°	4°	4°
30" OD - 37" OD Inclusive	1-1/2°	3°	3-1/2°
37" OD - 42" OD Inclusive		2-1/2°	3-1/2°
42" OD - 49" OD Inclusive		2°	3°
49" OD - 54" OD Inclusive		2°	3°
54" OD - 66" OD Inclusive		2°	2-1/2°
66" OD - 78" OD Inclusive			2°
78" OD - 90" OD Inclusive			1-1/2°

Methods of Supporting Coupled Lines

Shown below are three options for supporting pipeline connections when using Dresser couplings.

Figure A shows the offset method near the pipe joint for diameters 6" and smaller with pipe lengths up to 20 feet. Suitable for any pressure providing pipe is anchored to support for high pressure.

Figure B indicates the center-type support for diameters from 6" to 16" and lengths not over 20 feet. This method is suitable

for pressures up to 25 lb. maximum with pipe fully anchored to supports.

Figure C shows the "Two & One" method for all sizes and any length of pipe up to 40 feet. Suitable for any pressure providing pipe is adequately anchored. When utilizing this method each length of pipe must be anchored to one (and ONLY one) support.

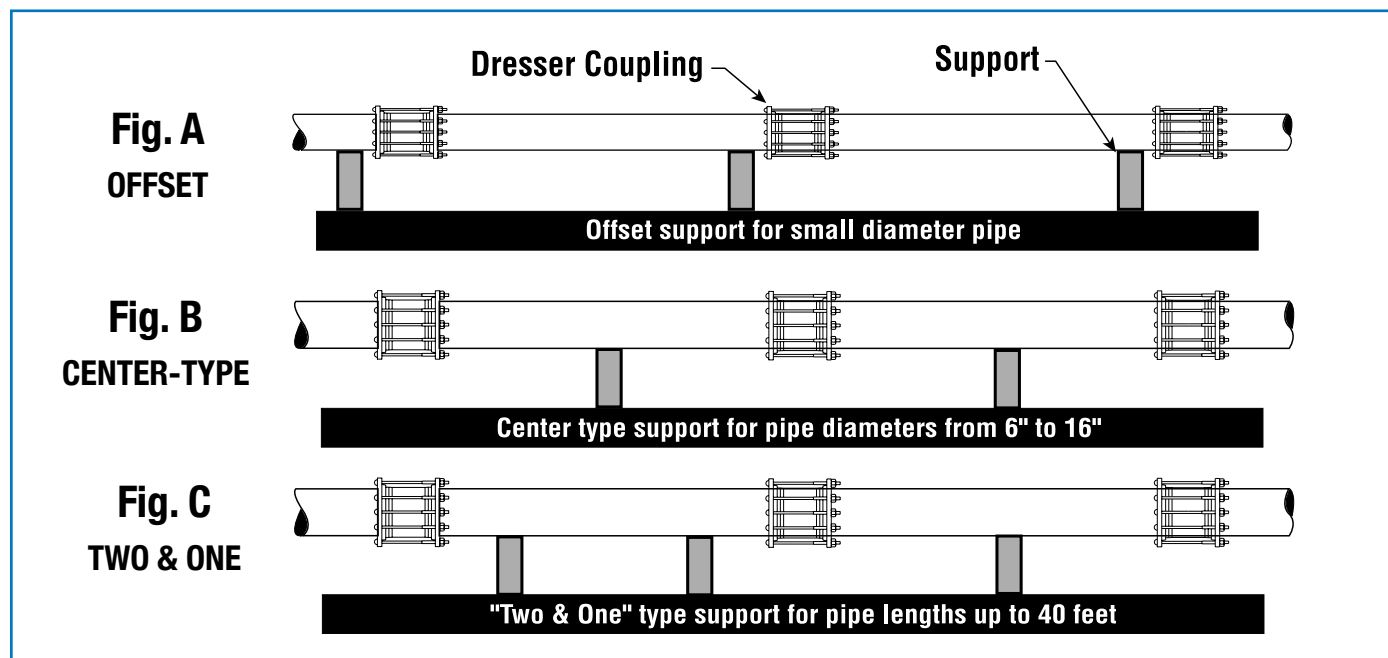



4" Light Pattern
Style 38



2" Light Pattern
Style 38

Style 38 Bolted Couplings for Steel Pipe

Proven by years of service on all kinds of pipe, Dresser Style 38 bolted-couplings provide flexible, leakproof connections that last the life of the pipe. No costly threading, beveling, exact pipe fitting or alignment is required.

The resilient Dresser gaskets absorb vibration and pipe movement and permit curves to be laid with straight pipe lengths. Dresser Style 38 couplings are available to fit 1/2" ID up to 108" outside diameter pipe. Also most sizes can be custom-built in all-stainless steel construction.

NOTE: Commonly used sizes are listed in the tables. 108" and larger diameter Penstock coupling are available upon requests. See the Penstock data sheet on-line: www.dresserutility.com



NSF61 and 372 Certified

Only products bearing the NSF Mark on the product, product packaging, and/or documentation shipped with the product are Certified.

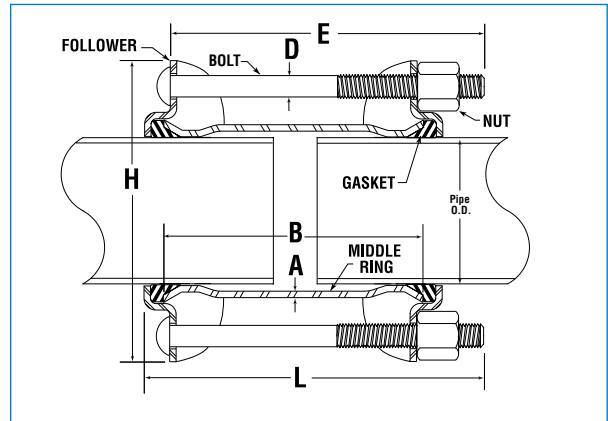

Materials of Construction

Followers	AISI C1012 or ASME SA36 (Ductile Iron or Malleable Iron for 1/2" thru 1-1/2")
Middle Ring	ASTM A513, ASTM A635 or ASME SA675 GR60
Bolts	AWWA C111/ANSI A21.11 Black Ecoat
Gaskets	Grade 27 BUNA-S As Standard
Coatings	Fusion-bonded Epoxy. All-SS Available

Style 38 Couplings

Sizes and Specifications for Steel Pipe

Pipe Nominal Size (in)	Outside Pipe Diameter (in)	Reference Dresser Part Number**	Middle Ring Thickness x Length (A&B)	Bolts Quantity Diam/Length (D&E)	Overall Dimensions Diam x Length (H&L)	Working Pressure Lbs. Per Sq.In	Approx. Weight Each (lbs)
1/2	.840	0038-0002-011	.156 x 3-1/2	2-1/2 x 6	3-1/2 x 8	1500	2
3/4	1.050	0038-0003-011	.156 x 5	2-1/2 x 7-1/4	3-13/16 x 8-1/2	1500	3
1	1.315	0038-0004-011	.156 x 5	2-1/2 x 7-1/4	4-1/16 x 8-1/2	1500	4
1-1/4	1.660	0038-0005-011	.156 x 5	2-1/2 x 7-1/4	4-7/16 x 8-1/2	1500	4
1-1/2	1.900	0038-0006-011	.156 x 5	2-1/2 x 7-1/4	4-3/4 x 8-1/2	1500	4.5
2	*2.375	0038-0011-011	.156 x 4	2-1/2 x 7-1/4	5-3/8 x 8-1/2	*	5
2	2.375	0038-0012-011	.156 x 5	2-5/8 x 8-1/4	6 x 9-1/2	1500	8
2	2.375	0038-0013-011	.156 x 5	3-5/8 x 8-1/4	6-1/4 x 9-1/2	1500	8
2	2.375	0038-0014-011	.156 x 7	3-5/8 x 10-3/4	6-1/4 x 11-1/2	1326	12.5
2-1/2	2.875	0038-0022-011	.180 x 5	3-5/8 x 8-1/4	7 x 9-1/2	1326	19
3	*3.000	0038-0023-011	.180 x 4	2-1/2 x 7-1/4	6 x 8-1/2	*	6.5
3	*3.500	0038-0025-011	.156 x 4	3-5/8 x 6	6 x 8-1/2	*	7
3	3.500	0038-9187-011	.156 x 5	4-5/8 x 7-1/4	6 x 8-1/2	982	13.5
3	3.500	0038-9188-011	.156 x 7	4-5/8 x 8-1/4	6 x 9-1/2	982	17.5
3-1/2	4.000	0038-0032-011	.180 x 4	3-1/2 x 7-1/4	6 x 8-1/2	*	6.5
4	*4.500	0038-0035-011	.180 x 4	3-5/8 x 6	7-1/2 x 8-1/2	*	8
4	4.500	0038-9036-011	.188 x 5	4-5/8 x 7-1/4	9 x 8-1/2	931	16.5
4	4.500	0038-9037-011	.188 x 7	4-5/8 x 8-1/4	9 x 9-1/2	931	23.5

* Light Pattern Couplings - Standard Pressure Rating of 150 PSI.

*NOTE: GASKETS - Part numbers listed are with standard Grade 27 BUNA-S gaskets. Consult factory for other gasket grades (Page 18) and pipe diameters

Style 38 Couplings (cont'd)

Sizes and Specifications for Steel Pipe

Pipe Nominal Size (in)	Outside Pipe Diameter (in)	Reference Dresser Part Number*	Middle Ring Thickness x Length (A&B)	Bolts Quantity Diam/Length (D&E)	Overall Dimensions Diam x Length (H&L)	Working Pressure Lbs. Per Sq.In	Approx. Weight Each (lbs)
5	5.500	0038-9042-011	.229 x 5	4-5/8 x 8-1/4	9-5/8 x 9-1/2	1205	23.5
5	*5.563	0038-0050-011	3/16 x 4	4-1/2 x 7-1/4	9-5/8 x 8	*	23.5
5	5.563	0038-9051-011	1/4 x 5	4-5/8 x 8-1/4	10-3/8 x 8-1/2	1205	23.5
5	5.563	0038-9052-011	1/4 x 7	4-5/8 x 8-1/4	10-3/8 x 9-1/2	1205	25
6	*6.000	0038-0053-011	.188 x 4	4-1/2 x 7-1/4	9-3/8 x 8	*	25
6	*6.625	0038-0056-011	.188 x 4	4-1/2 x 7-1/4	9-3/8 x 8	*	25
6	6.625	0038-9057-011	1/4 x 5	6-5/8 x 8-1/4	11-1/4 x 8-1/2	1029	31
6	6.625	0038-9058-011	1/4 x 7	6-5/8 x 8-1/4	11-1/4 x 8-1/2	1029	31
8	*8.625	0038-0072-011	.188 x 4	6-1/2 x 7-1/4	11-5/8 x 7-1/2	*	16
8	8.625	0038-9073-011	1/4 x 5	6-5/8 x 8-1/4	13-1/4 x 8-1/2	807	32
8	8.625	0038-9074-011	1/4 x 7	6-5/8 x 8-1/4	13-1/4 x 9-1/2	807	38
10	10.000	0038-8082-011	1/4 x 5	8-5/8 x 7-1/4	13-5/8 x 8-1/2	703	39
10	10.750	0038-9085-011	1/4 x 5	8-5/8 x 8-1/4	14-5/8 x 8-1/2	657	40
10	10.750	0038-9086-011	1/4 x 7	8-5/8 x 8-1/4	14-5/8 x 9-1/2	657	49
10	10.750	0038-9086-011	3/8 x 7	8-5/8 x 8-1/4	14-5/8 x 9-1/2	813	53
12	12.000	0038-8095-011	1/4 x 7	8-5/8 x 8-1/4	16 x 9-1/2	591	55
12	12.750	0038-9098-011	1/4 x 5	8-5/8 x 8-1/4	16-3/4 x 8-1/2	558	45
12	12.750	0038-9099-011	1/4 x 7	8-5/8 x 8-1/4	16-3/4 x 9-1/2	558	56
12	12.750	0038-9501-011	3/8 x 7	8-5/8 x 8-1/4	16-3/4 x 9-1/2	754	65
14	14.000	0038-8107-011	1/4 x 7	8-5/8 x 10-3/4	18 x 10-7/8	510	60
14	14.000	0038-8502-011	3/8 x 7	8-5/8 x 10-3/4	18 x 10-7/8	813	72
16	16.000	0038-8115-011	1/4 x 7	10-5/8 x 10-3/4	20 x 10-7/8	449	70
16	16.000	0038-8514-011	3/8 x 7	10-5/8 x 10-3/4	20 x 10-7/8	537	82
18	18.000	0038-8129-011	1/4 x 7	10-5/8 x 10-3/4	20 x 10-7/8	401	75
18	18.000	0038-8505-011	3/8 x 7	10-5/8 x 10-3/4	20 x 10-7/8	595	88
20	20.000	0038-8134-011	1/4 x 7	12-5/8 x 10-3/4	24 x 10-7/8	362	83
20	20.000	0038-8507-011	3/8 x 7	12-5/8 x 10-3/4	24 x 10-7/8	538	99
24	24.000	0038-8141-011	1/4 x 7	14-5/8 x 10-3/4	28 x 10-7/8	304	105
24	24.000	0038-8510-011	3/8 x 7	14-5/8 x 10-3/4	28 x 10-7/8	451	120
30	30.000	0038-8207-011	1/4 x 7	16-5/8 x 10-3/4	34 x 10-7/8	243	120
30	30.000	0038-8512-011	3/8 x 7	16-5/8 x 10-3/4	34 x 10-7/8	303	153
36	36.000	0038-8513-011	3/8 x 7	18-5/8 x 10-3/4	40 x 10-7/8	451	120
42	42.000	0038-0004-200	3/8 x 7	20-5/8 x 10-3/4	47 x 16-1/2	346	242
48	48.000	0038-0033-520	3/8 x 7	22-5/8 x 10-3/4	53 x 16-1/2	304	289

*Light Pattern Couplings - Standard Pressure Rating of 150 PSI.

*NOTE: GASKETS - Part numbers listed are with standard Grade 27 BUNA-S gaskets. Consult factory for other gasket grades (Page 18) and pipe diameters

*NSF 61 & 372 certified



Style 138 and 38 Bolted Couplings for CIP/DIP

Now you can stock one coupling in each nominal size, 4" through 12", and be sure of a fit, whether the cast-iron pipe was made in 1890 or from your latest ductile iron shipment. The unique feature of this product is one middle ring can be used with up to four different gaskets and three followers to cover a wide range of pipes.

Style 38 Couplings for CIP/DIP

Available for cast and ductile iron pipe sizes 14" and larger. These couplings have long been used for joining plain end cast-iron and ductile iron pipe, combining the advantages of absolutely tight joints and easier, faster pipe joining. Style 38 couplings also permit the salvage and use of random lengths of cast/ductile pipe from which bell-ends or cracked sections have been removed.



NSF61 and 372 Certified

Only products bearing the NSF Mark on the product, product packaging, and/or documentation shipped with the product are Certified.

Materials of Construction	
Followers	AISI C1012 or ASME SA36
Middle Ring	ASTM A513, ASTM A635 or ASME SA675 GR60
Bolts	AWWA C111/ANSI A21.11. Black Ecoat
Gaskets	Grade 27 BUNA-S As Standard Optional gaskets available
Coatings	Fusion-bonded Epoxy. ID/OD Standard Optional Dresser RED-D Shopcoat

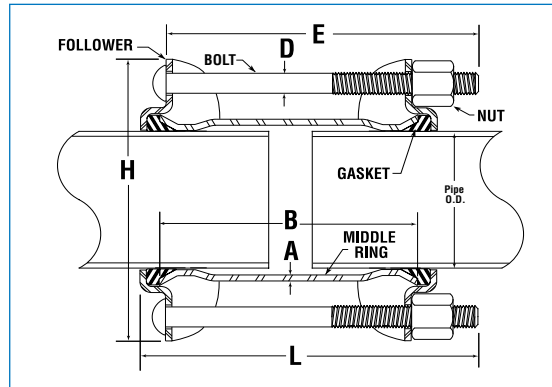

Style 138 Couplings (3" thru 12") and Style 38 (14"- 48" and larger)

Sizes and Specifications for Plain-end Cast Iron and Ductile Iron Pipe

Pipe Nominal Size (in)	Outside Pipe Diameter (in)	Reference Dresser Part Number*	Middle Ring Thickness x Length (A&B)	Bolts Quantity Diam/Length (D&E)	Overall Dimensions Diam x Length (H&L)	Working Pressure Lbs. Per Sq.In	Approx. Weight Each (lbs)
3	3.74 - 4.02	0138-0300-009	.299 X 5	4- 5/8 x 8-1/4	6-1/2 x 9-1/2	250	15
4	4.74 - 5.06	0138-0400-009	.188 X 5	4- 5/8 x 9-1/2	9 x 9-5/8	250	15
6	6.90 - 7.16	0138-0600-009	1/4 X 5	5- 5/8 x 8-1/4	11 x 9-1/2	250	21
8	9.05 - 9.36	0138-0800-009	1/4 X 5	6- 5/8 x 8-1/4	13-1/16 x 9-1/2	250	31
10	11.10 - 11.46	0138-1000-009	1/4 X 5	7- 5/8 x 10-3/4	16 x 9-1/2	250	47
12	13.20 - 13.56	0138-1200-009	1/4 X 5	8- 5/8 x 10-3/4	18-1/16 x 9-1/2	250	50
12	13.20 - 13.56	0138-0011-009	3/8 X 7	8- 5/8 x 10-3/4	18-1/16 x 10-7/8	250	54
14	15.30	0038-8503-011	3/8 X 7	10- 5/8 x 10-3/4	19-5/16 x 10-7/8	575	74
16	17.40	0038-8504-011	3/8 X 7	10- 5/8 x 10-3/4	20-5/8 x 10-7/8	509	88
18	19.50	0038-8506-011	3/8 X 7	12- 5/8 x 10-3/4	23-1/2 x 10-7/8	450	120
20	21.60	0038-8508-011	3/8 X 7	12- 5/8 x 10-3/4	25-5/8 x 10-7/8	411	130
24	25.80	0038-8511-011	3/8 X 7	15- 5/8 x 10-3/4	29-3/16 x 10-7/8	349	155
30	32.00	0038-8034-690	3/8 X 7	16- 5/8 x 10-3/4	34-1/2 x 10-7/8	342	197
36	38.30	0038-8034-520	3/8 X 7	20- 5/8 x 10-3/4	40-5/8 x 10-7/8	287	230
42	44.50	0038-0033-840	3/8 X 7	20- 5/8 x 10-3/4	46-3/8 x 10-7/8	248	263
48	50.80	0038-0035-090	3/8 X 7	24- 5/8 x 10-3/4	52-3/4 x 10-7/8	218	303

*NOTE: GASKETS - Part numbers listed are with standard Grade 27 BUNA-S gaskets. Consult factory for other gasket grades (Page 18) and pipe diameters

*NSF 61 & 372 certified



For widely separated pipe ends

Style 40 Long Body Couplings

Dresser Style 40 Long Body Couplings provide a simple and effective method of joining pipe when gaps in pipe ends are wider than ordinary. Style 40 couplings are similar in construction to Style 38 couplings except that middle rings are longer and have a larger belly diameter. Though longer, they absorb the same amount of expansion and contraction as the Style 38 coupling, up to 3/8" per joint.



NSF61 and 372 Certified

Only products bearing the NSF Mark on the product, product packaging, and/or documentation shipped with the product are Certified.

Materials of Construction	
Followers	AISI C1012 or ASME SA36 (Ductile Iron or Malleable Iron for Steel Pipe 1/2" thru 1-1/2")
Middle Ring	ASTM A513, ASTM A635 or ASME SA675 GR60
Bolts	AWWA C111/ANSI A21.11. Black Ecoat
Gaskets	Grade 27 BUNA-S As Standard
Coatings	Fusion-bonded Epoxy Optional Dresser RED-D Shopcoat

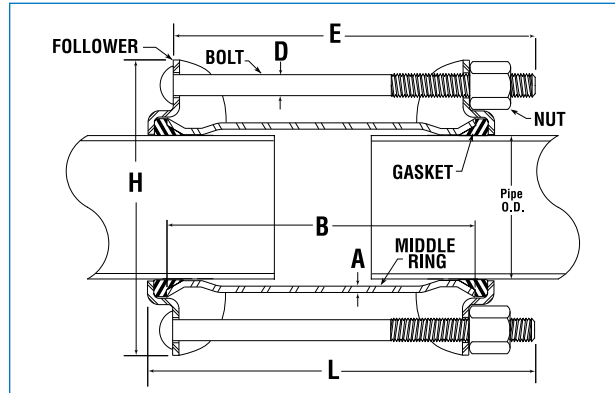

Style 40 Long Body Couplings

Specifications for Pipe Sizes 1/2" thru 12"; with 12" and 16" long middle rings

Pipe Nominal Size (in)	Outside Pipe Diameter (in)	Reference Dresser Part Number*	Middle Ring Thickness x Length (A&B)	Bolts Quantity Diam/Length (D&E)	Overall Dimensions Diam x Length (H&L)	Working Pressure Lbs. Per Sq.In	Approx. Weight Each (lbs)
1/2	.840	0040-0001-003	.156 X 12	2- 9/16 x 14	3-1/2 x 15-5/8	1500	4.5
3/4	1.050	0040-0002-003	.156 X 12	2- 9/16 x 14	3-13/16 x 15-5/8	1500	5
1	1.315	0040-0003-003	.156 X 12	2- 9/16 x 14	4-1/16 x 15-5/8	1500	6
1-1/4	1.660	0040-0004-003	.156 X 12	2- 9/16 x 14	4-7/16 x 15-5/8	1500	6.5
1-1/2	1.900	0040-0005-003	.165 X 12	2- 9/16 x 14	4-1/4 x 17	1500	7.5
2	2.375	0040-0007-003	.156 X 12	3- 5/8 x 15	6-3/4 x 17	1500	15
2 CIP	2.500	0040-0009-003	.180 X 12	3- 5/8 x 15	7 x 17	1302	17
2	2.875	0040-0015-003	.180 X 12	3- 5/8 x 15	7 x 17	1500	20
3	3.500	0040-9018-003	.156 X 12	4- 1/2 x 15	8 x 17	1500	23
3 CIP	3.74 - 4.02	0040-0202-003	.156 X 12	4- 5/8 x 15	8 x 17	930	25
4	4.500	0040-9025-003	.156 X 12	4- 5/8 x 15	9 x 17	1063	28
4 CIP	4.74 - 5.06	0040-9203-003	1/4 X 12	6- 5/8 x 19-1/2	9 x 17	250	29
6	6.625	0040-0202-003	1/4 X 16	6- 5/8 x 19-1/2	11-1/4 x 21	968	51
6 CIP	6.84 - 7.16	0040-9204-003	1/4 X 16	6- 5/8 x 19-1/2	11-1/4 x 21	948	54
8	8.625	0040-9049-003	1/4 X 16	6- 5/8 x 19-1/2	13-1/4 x 21	769	63
8 CIP	8.99 - 9.36	0040-0205-003	1/4 X 16	6- 5/8 x 19-1/2	13-1/4 x 21	740	70
10	10.75	0040-9057-003	1/4 X 16	8- 5/8 x 19-1/2	14-5/8 x 21	632	109
10 CIP	11.04 - 11.76	0040-0205-003	3/8 X 16	8- 5/8 x 19-1/2	15-13/16 x 21-3/4	908	112
12	12.75	0040-9110-003	1/4 X 16	8- 5/8 x 19-1/2	16-3/4 x 21-3/4	520	119
12 CIP	13.14- 13.56	0040-0207-003	3/8 X 16	8- 5/8 x 19-1/2	18-13/16 x 21-3/4	776	135

*NOTE: GASKETS - Part numbers listed are with standard Grade 27 BUNA-S gaskets. Consult factory for other gasket grades (Page 18) and pipe diameters

Style 40 Long Body Couplings (cont'd)

Specifications for Pipe Sizes 14" thru 36"; with 16" long middle rings

Pipe Nominal Size (in)	Outside Pipe Diameter (in)	Reference Dresser Part Number*	Middle Ring Thickness x Length (A&B)	Bolts Quantity Diam/Length (D&E)	Overall Dimensions Diam x Length (H&L)	Working Pressure Lbs. Per Sq.In	Approx. Weight Each (lbs)
14	14.00	0040-8228-003	1/4 X 16	8- 5/8 x 19-1/2	18 x 21-3/4	510	130
14 CIP	15.30	0040-8073-003	3/8 X 16	8 -5/8 x 19-1/2	18-13/16 x 21-3/4	776	155
16	16.00	0040-8231-003	1/4 X 16	10- 5/8 x 19-1/2	21 x 21-3/4	449	148
16 CIP	17.40	0040-8079-003	3/8 X 16	10 -5/8 x 19-1/2	21 x 21-3/4	600	167
18	18.00	0040-8234-003	1/4 X 16	10- 5/8 x 19-1/2	22 x 21-3/4	400	175
18 CIP	19.50	0040-8085-003	3/8 X 16	12 -5/8 x 19-1/2	23-7/8 x 21-3/4	539	203
20	20.00	0040-8237-003	1/4 X 16	12- 5/8 x 19-1/2	24 x 21-3/4	362	201
20 CIP	21.60	0040-8XXX-XXX	3/8 X 16	12 -5/8 x 19-1/2	25-5/8 x 21-3/4	490	226
22	22.00	0040-8240-003	1/4 X 16	14- 5/8 x 19-1/2	24 x 21-3/4	330	224
24	24.00	0040-8243-003	1/4 X 16	14- 5/8 x 19-1/2	28 x 22-3/4	304	240
24 CIP	25.80	0040-8XXX-XXX	3/8 X 16	15 -5/8 x 20	30-5/8 x 22-3/4	414	258
30	30.00	0040-0005-750	3/8 X 16	16- 5/8 x 19-1/2	34 x 22-3/4	282	290
36	36.00	0040-8000-060	3/8 X 16	18- 5/8 x 19-1/2	40 x 22-3/4	262	345

*NOTE: Consult factory for larger available sizes.

Style 40 Long Body Couplings (cont'd)

Specifications for Pipe Sizes 2" thru 12"; with 24" long middle rings

Pipe Nominal Size (in)	Outside Pipe Diameter (in)	Reference Dresser Part Number*	Middle Ring Thickness x Length (A&B)	Bolts Quantity Diam/Length (D&E)	Overall Dimensions Diam x Length (H&L)	Working Pressure Lbs. Per Sq.In	Approx. Weight Each (lbs)
2	2.375	0040-0008-003	.156 X 24	3- 1/2 x 28	6-1/4 x 29	1500	33
3	3.500	0040-9019-003	.156 X 24	4 -5/8 x 28	8- x 29	1500	40
4	4.500	0040-9026-003	.188 X 24	4- 5/8 x 28	9 x 29	1063	44
6	6.625	0040-9040-003	1/4 X 24	6 -5/8 x 28	11-1/4 x 29	968	60
8	8.625	0040-9050-003	1/4 X 24	6- 5/8 x 28	13-7/8 x 29	769	85
10	10.75	0040-9058-003	1/4 X 24	8 -5/8 x 28	14-5/8 x 29	632	91
12	12.75	0040-8066-003	3/8 X 24	8- 5/8 x 28	17-1/8 x 29-3/4	690	165

*NOTE: GASKETS - Part numbers listed are with standard Grade 27 BUNA-S gaskets. Consult factory for other gasket grades (Page 18) and pipe diameters

- Part numbers listed are with standard Grade 27 BUNA-S gaskets. Consult factory for other gasket grades (Page 18) and pipe diameters

*NSF 61 & 372 certified in Grade 27 and EPDM

Style 40 Long Body Couplings (cont'd)

Specifications for Pipe Sizes 16" thru 42"; with 24" long middle rings

Pipe Nominal Size (in)	Outside Pipe Diameter (in)	Reference Dresser Part Number*	Middle Ring Thickness x Length (A&B)	Bolts Quantity Diam/Length (D&E)	Overall Dimensions Diam x Length (H&L)	Working Pressure Lbs. Per Sq.In	Approx. Weight Each (lbs)
16	16.00	0040-8085-003	3/8 X 24	12 -5/8 x 28	23-7/8 x 29-3/4	537	203
18 CIP	19.92	0040-8508-003	3/8 X 24	12 -5/8 x 28	23-5/8 x 29	529	269
20	20.00	0040-8237-003	3/8 X 24	12- 5/8 x 28	24 x 29-3/4	538	269
22	22.00	0040-8094-003	3/8 X 24	14- 5/8 x 28	24 x 29-3/4	491	299
24	24.00	0040-8098-003	3/8 X 24	15 -5/8 x 28	30-5/8 x 29-3/4	451	325
24 CIP	25.80	0040-0005-780	3/8 X 24	15- 5/8 x 28	33 x 29	406	275
30	30.00	0040-8002-150	3/8 X 24	16 -5/8 x 28	34-5/8 x 30-1/4	414	388
36	36.00	0040-8002-510	3/8 X 24	18- 5/8 x 28	40-3/8 x 30-14	305	417
42	42.00	0040-0005-860	3/8 X 24	20- 5/8 x 28	46 x 30-1/4	262	488

*NOTE: GASKETS - Part numbers listed are with standard Grade 27 BUNA-S gaskets. Consult factory for other gasket grades (Page 18) and pipe diameters
 - Part numbers listed are with standard Grade 27 BUNA-S gaskets. Consult factory for other gasket grades (Page 18) and pipe diameters

*NSF 61 & 372 certified in Grade 27 and EPDM

All Stainless Steel Couplings



Style 38
Stainless Steel Coupling
sizes and dimensional
specifications are comparable
to standard Style 38 coupling
charts as listed on pages 5-6.

For severe service conditions!

When you need a coupling for highly corrosive conditions - too corrosive for ordinary carbon steel couplings - Dresser offers its proven Style 38 coupling in an all-stainless steel design. Custom-built to order, the all-metal stainless coupling is available with a combination of both Type 304 and Type 316 stainless steel components. Followers are available in Type 316 only. You can also specify the middle ring only in stainless or the bolts and nuts only in stainless. Meets all specifications in accordance with AWWA C219.

All Stainless Steel bolted coupling products shall include the following materials:

Middle Ring: Type 316-SS to ASTM 240 w/No. 1 mill finish (Type 304 Optional)

- Sleeve thickness at least equal to pipe wall thickness in smaller sizes
- Center sleeve middle ring body includes label identification with part number, sizing
- A380 Pickle & Passivation finish optional

Followers: Type 316-SS Only. Single Piece thru 12" size; 2-piece bar follower for larger sizes.

Mill section cold expanded to 1%

Gaskets: Plain Grade 27 BUNA-S as standard; Grade 42 BUNA-N, Viton, Butyl and EPDM optional

Bolts: Type 316; Rolled threads.

Nuts: Type 316, Xylan-Coated

*Viton is a Registered trademark of Dupont Corporation



For connecting different sizes and types of pipe

Style 62 Reducing/ Transition Couplings

Dresser Style 62 Reducing Couplings are ideal for (1) when joining size-on-size steel and cast iron pipe; (2) when making actual reductions in pipe size; and (3) when changing the class of pipe. They can also be supplied for connections between any two kinds or sizes of pipe.

Type I Reducing Couplings are for reductions where the differences in pipe diameters is small, as from standard cast iron to steel of the same nominal size. Standard Style 38 parts are used except the middle ring is swaged on one end.

Type II Reducing Couplings are for larger and special reductions outside the standard range of Type I. They are made from Style 38 parts with anchor rings welded to the middle ring. Two sets of bolts are supplied.

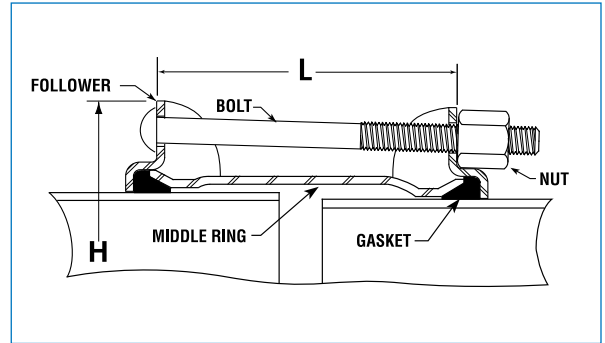

NOTE: Style 39-62 Insulating-Reducing couplings are also available for joining pipes of different OD's and dissimilar metals requiring cathodic protection.



NSF61 and 372 Certified

Only products bearing the NSF Mark on the product, product packaging, and/or documentation shipped with the product are Certified.

Materials of Construction	
Followers	AISI C1012 or ASME SA36
Middle Ring	ASTM A513, ASTM A635 or ASME SA675 GR60
Bolts	AWWA C111/ANSI A21.11. Black Ecoat
Gaskets	Grade 27 BUNA-S As Standard
Coatings	Fusion-bonded Epoxy

Type II Transition Couplings

Custom-Built to Order

Dresser Transition Couplings permit you to connect two unusually different sizes and types of pipe. The drawing illustrates how larger adjustments are accomplished with custom-built reducing middle rings. Please consult factory for your particular requirements.

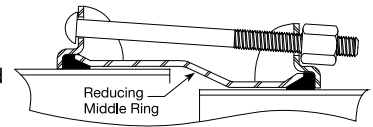

Specially Fabricated Middle Ring

Style 62 Reducing Couplings - Type I

Size-on-Size Specifications for Standard Cast/Ductile Iron Pipe x Steel Pipe Connections

Pipe Nominal Size (in)	Outside Diameter Cast Iron (in)	Outside Diameter Steel (in)	Reference Dresser Part Number*	Middle Ring Thickness x Length (in)	Bolts Quantity Diam/Length (in)	Overall Dimensions Diam x Length (H&L)	Working Pressure Lbs. Per Sq.In	Approx. Weight Each (lbs)
3	3.74 - 4.02	3.500	0062-9502-142	1.88 X 5	4- 5/8 x 8-1/4	7-3/4 x 9-1/2	150	16
4	4.74 - 5.06	4.500	0062-9504-142	.299 X 7	4- 5/8 x 10-3/4	9 x 11-7/8	150	25
6	6.90 - 7.16	6.000	0062-9505-142	1/4 X 7	6- 5/8 x 10-3/4	9 x 11-7/8	150	27
6	6.90 - 7.16	6.625	0062-9506-142	1/4 X 7	6- 5/8 x 10-3/4	11-3/4 x 11-7/8	150	27
8	9.05 - 9.36	8.625	0062-0508-142	1/4 X 7	6- 5/8 x 10-3/4	13-3/4 x 11-7/8	150	37
10	11.10 - 11.46	10.750	0062-0509-142	3/8 X 7	8- 5/8 x 10-3/4	15-3/4 x 11-7/8	150	58
12	13.20 - 13.56	12.750	0062-0510-142	3/8 X 7	8- 5/8 x 10-3/4	17-3/4 x 11-7/8	150	83
14	15.30	14.000	0062-8009-550	3/8 X 7	8- 5/8 x 10-3/4	19-3/4 x 11-7/8	150	85
16	17.40	16.000	0062-8050-011	3/8 X 7	10- 5/8 x 10-3/4	21-3/4 x 11-7/8	150	101
18	19.50	18.000	0062-8009-560	3/8 X 7	10- 5/8 x 10-3/4	23-3/4 x 11-7/8	150	117
20	21.60	20.000	0062-8051-011	3/8 X 7	12- 5/8 x 10-3/4	25-3/4 x 11-7/8	150	130
24	25.80	24.000	0062-8052-011	3/8 X 7	14- 5/8 x 10-3/4	29-3/4 x 11-7/8	150	162

NOTE: Consult factory for Style 39-62 Insulating-Reducing coupling specifications. Also for custom-built Type II transition couplings for joining pipes of different OD's and dissimilar metals

*NOTE: GASKETS - Part numbers listed are with standard Grade 27 BUNA-S gaskets. Consult factory for other gasket grades (Page 18) and pipe diameters

*NSF 61 & 372 certified



For drilled-end pipe
Creates a restraining
connection

Style 167 Lock Couplings

Provides additional holding strength under unusual service conditions

Dresser Style 167 Lock Couplings actually “lock” the pipe and the coupling together to protect the line from pipe separation due to unusual movement. These couplings are for exceptional conditions such as ash handling and coal transmission lines, or unanchored high-pressure surface lines where added holding strength is desired.

Style 167 lock couplings utilize standard Style 38 parts with the addition of leak-proof locking pins. The locking arrangement consists of threaded steel locking plugs at each end which extend through the middle ring into corresponding holes drilled in the pipe ends. This construction permits a “universal joint” action of the pipe in the coupling, yet prevents the pipe from pulling out under excessive longitudinal stresses.



NSF61 and 372 Certified

Only products bearing the NSF Mark on the product, product packaging, and/or documentation shipped with the product are Certified.

Style 167 Lock Couplings

Specifications for Sizes 3” thru 12”

STYLE 167 FOR DRILLED-END STEEL PIPE			
Nominal Size (in)	Pipe OD (in)	Middle Ring Length (in)	Shipping Weight (lbs.)
3	3.500	10	17
3-1/2	4.000	10	19
4	4.500	10	21
4-1/2	5.000	10	22
5	5.562	10	25
	6.000	10	30
6	6.625	10	31
	7.000	10	33
6	8.000	10	37
	8	8.625	10
8	10.000	10	46
	10	10.750	10
12	12.750	10	58
STYLE 167 FOR DRILLED-END CIP/DIP			
Nominal Size (in)	Pipe OD (in)	Middle Ring Length (in)	Shipping Weight (lbs.)
3	3.800	10	19
	3.960	10	19
4	4.800	10	24
	5.000	10	24
6	6.900	10	31
	7.100	10	33
8	9.050	10	39
	9.300	10	42
10	11.100	10	64
	11.400	10	65
12	13.200	10	88
	13.500	10	90

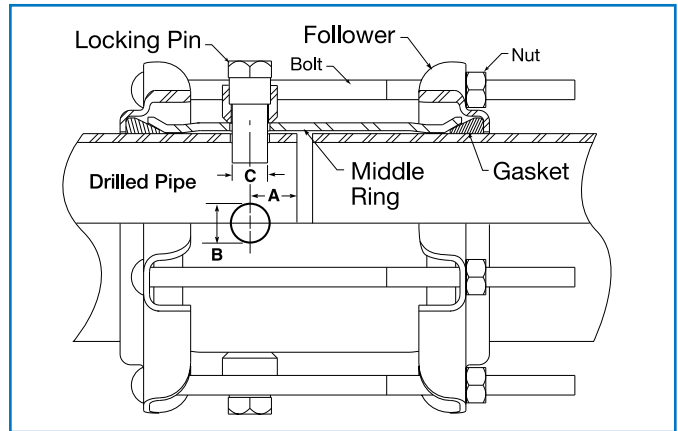

Style 167 Pipe-Drilling Table			
Locking Pin*		Drilling Dimensions	
Nominal Size	Lock Pin Diameter (C)	Distance From End of Pipe (A)	Drill Size (B)
1/2"	11/16"	15/16"	13/16"
3/4"	29/32"	1-1/4"	1-1/16"
1"	1-1/8"	1-7/16"	1-1/4"

*Standard locking pin quantity is four per coupling

Materials of Construction	
Followers	AISI C1012 or ASME SA36
Middle Ring	ASTM A513, ASTM A635 or ASME SA675 GR60
Bolts	AWWA C111/ANSI A21.11
Locking Pin	AISI C1212 Carbon Steel
Gaskets	Grade 27 BUNA-S
Coatings	Fusion-bonded Grey Epoxy



Style 128 Flange Adapter

Fabricated from high-strength steel, Dresser Style 128 Flange Adapters afford the engineer a complete size range up to 24" diameter in steel and cast-iron pipe sizes. Standard flanges are AWWA C-207 Class-D. Flanges for higher pressure ratings can be supplied to U.S. and international standards.

The compression end of the adapter has a Dresser coupling type design utilizing a wedge gasket for an efficient, leak-proof seal. Insulating designs can also be furnished. The Style 128 can also be custom-fabricated with lock pins to provide anchorage to the pipe. Consult factory for your specific requirements.



Only products bearing the NSF Mark on the product, product packaging, and/or documentation shipped with the product are Certified.

NSF61 and 372 Certified

Materials of Construction	
Followers	AISI C1012 or ASME SA36
Middle Ring	ASTM A513, ASTM A635 or ASME SA675 GR60
Bolts	AWWA C111/ANSI A21.11. Black Ecoat
Flange	AWWA C-207 Class D As Standard
Gaskets	Grade 27 BUNA-S
Coatings	Fusion-bonded Epoxy Dresser RED-D Shopcoat Optional

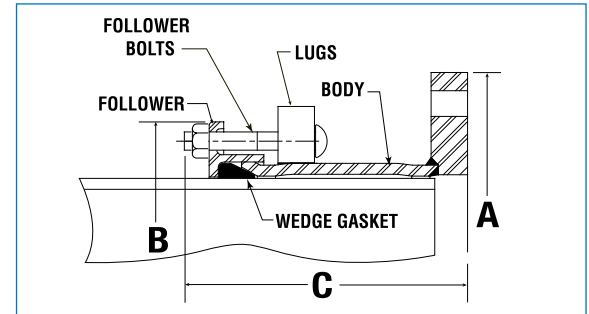

Style 128 Flange Adapter - 150 MAOP All Sizes

Specifications for Pipe Sizes 3" thru 24"

Pipe Nominal Size (in)	Outside Pipe Diameter (in)	Reference Dresser Part Number*	Body Ring Thickness x Length (in)	Follower Bolts Quantity Diam/Length (in)	Overall Dimensions Diam x Length (B&C)	Overall Flange Diameter (A)	Approx. Weight Each (lbs)
3	3.500	0128-19??-002	.156 X 7	4- 5/8 x 4	7-3/8 x 8-5/8	7.50	20
3 CIP	3.74 - 4.02	0128-19??-002	.188 X 7	4- 5/8 x 4	7-3/4 x 8-11/16	9	25
4	4.500	0128-1850-002	.188 X 7	4- 5/8 x 4	8-3/4 x 8-13/16	9	25
4 CIP	4.74 - 5.06	0128-1900-002	.229 X 7	4- 5/8 x 4	9 x 9-1/16	9	167
6	6.625	0128-1852-002	1/4 X 7	6- 5/8 x 4	10-1/2 x 9-1/16	11	38
6 CIP	6.84 - 7.16	0128-9902-002	1/4 X 7	6- 5/8 x 4	11-13/16 x 9-1/16	11	36
8	8.625	0128-1854-002	1/4 X 7	6- 5/8 x 4	12-7/16 x 9-1/16	13.50	52
8 CIP	8.99 - 9.36	0128-1904-002	1/4 X 7	6- 5/8 x 4	13-1/2 x 9-1/16	13.50	48
10	10.750	0128-9856-002	1/4 X 7	8- 5/8 x 4	14-5/8 x 9-3/16	16.00	58
10 CIP	11.04 - 11.46	0128-1908-002	3/8 X 7	8- 5/8 x 4	15-9/16 x 9-3/16	16.00	69
12	12.750	0128-9858-002	1/4 X 7	8- 5/8 x 4	16-3/4 x 9-11/16	19.00	79
12 CIP	13.14 - 13.56	0128-1908-002	3/8 X 7	8- 5/8 x 4-1/2	17-3/16 x 9-11/16	19.00	95
14	14.00	0128-8860-002	3/8 X 7	10- 5/8 x	18 x 9-3/4	21.00	89
14 CIP	15.30	0128-8912-002	3/8 X 7	10- 5/8 x 4-1/2	19-3/8 x 9-3/4	21.00	112
16	16.00	0128-8862-002	3/8 X 7	10- 5/8 x 4	21-7/16 x 9-3/4	23.500	103
16 CIP	17.40	0128-8910-002	3/8 X 7	10- 5/8 x 4-1/2	19-3/8 x 9-3/4	23.50	132
18	18.00	0128-8864-002	3/8 X 7	10- 5/8 x 4-1/2	22 x 9-3/4	25.00	112
18 CIP	19.50	0128-8914-002	3/8 X 7	10- 5/8 x 4-1/2	23-1/2 x 9-3/4	25.00	151
24	24.00	0128-8868-002	3/8 X 7	14- 5/8 x 4-1/2	18 x 10	32.00	184
24 CIP	25.80	0128-8918-002	3/8 X 7	10- 5/8 x 4-1/2	29-13/16 x 10	32.00	230

*NOTE: GASKETS - Part numbers listed are with standard Grade 27 BUNA-S gaskets. Consult factory for other gasket grades (Page 18) and pipe diameters



Dresser Dismantling Joints can be supplied with a variety of gasket compounds for compatibility with line content, plus other flanges for higher operating pressures.

Style 131 Dismantling Joints

The Dresser Style 131 Dismantling Joint is a double-ended flanged adapter that allows for longitudinal adjustment in piping systems where flanged end pipe is the standard. This product will provide the maximum in flexibility when installing and maintaining flanged end pipe interfaces with check valves, gate valves, ball valves, pumps, blowers, meters, engines, compressors, various fittings and appurtenances.

A typical dismantling joint would be used anywhere that a flanged end piping accessory, such as a valve or pump, requires quick installation or removal. The product eliminates the need to drop an inlet or discharge pipe leg normally associated with flanged end pipe. It also allows for up to 2 degrees of misalignment, and can be designed to provide from 2" to 20" of longitudinal adjustment to the pipe ends.

This longitudinal adjustment, provided by a telescoping flanged spool piece, can be limited with the addition of tie rods, which are integral with the joint. As a consequence of this flexibility, center to center dimensions become less critical to the installer and installation time is reduced considerably.

Dresser Dismantling Joints are available in diameters ranging from 4" through 24" in standard designs, and up to 96" in diameter for custom-engineered designs. Fabricated in either carbon steel or stainless steel, standard design features flanges supplied to AWWA specification C-207 with a maximum working pressure of 150 PSI. Flanges manufactured to other U.S. and international standards and higher pressure ratings available upon request.



NSF61 and 372 Certified

Only products bearing the NSF Mark on the product, product packaging, and/or documentation shipped with the product are Certified.

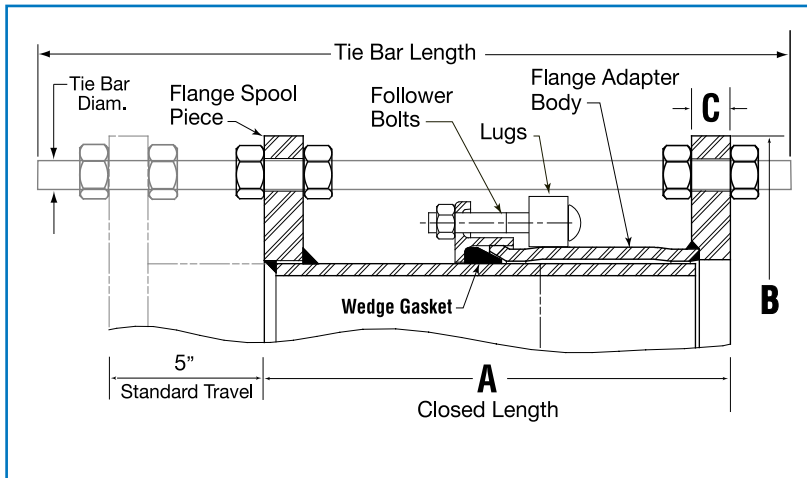

Materials of Construction	
Body	AISI C1010 C1015
Flange	AWWA C-207 Class D As Standard
Spool Piece	Steel - AISI C1010 C1015
Gasket	Grade 27 BUNA-S As Standard
Coatings	Fusion-bonded Epoxy Optional Dresser RED-D Shopcoat
Bolts	AWWA C111/ANSI A21.11. Black Ecoat
Tie Rods (2)	Steel - ASTM A193 Grade B7
Nuts	ASTM A194 Grade 2H

Style 131 Dismantling Joint - Dimension Specifications 4" through 24"

Nominal Size (in)	Closed Length (A)	Tie Rod ¹		Min. Flange Thickness (C)	Flange OD (B)	Nominal Size (in)	Closed Length (A)	Tie Rod ¹		Min. Flange Thickness (C)	Flange OD (B)
		Diam. (in)	Length (in)					Diam. (in)	Length (in)		
4"	12-3/8"	5/8"	22"	5/8"	9"	14"	14"	1"	26"	15/16"	21"
5"	12-3/8"	5/8"	22"	5/8"	10"	16"	14-1/8"	1"	26"	1"	23-1/2"
6"	12-3/4"	3/4"	24"	11/16"	11"	18"	14-1/2"	1-1/8"	26"	1-1/16"	25"
8"	12-3/4"	3/4"	24"	11/16"	13-1/2"	20"	14-5/8"	1-1/8"	26"	1-1/18"	27-1/2"
10"	13-1/4"	7/8"	24"	11/16"	16"	24"	15-1/8"	1-1/4"	28"	1-1/4"	32"
12"	13-3/8"	7/8"	24"	13/16"	19"						

NOTE 1: Tie Rods are optional by request. Tie rods are designed for 150 PSI Maximum Working Pressure.

NOTE 2: Other flanges and larger sizes available on request. (e.g. ANSI 150# and 300#)



For absorbing concentrated pipe movement

NOTE:

See Page 2 for Style 63 ordering information

Style 63 Expansion Joints

Dresser offers the broadest line of Style 63 Expansion Joints including Type 1 and Type 3 as shown below, with flanged or welded ends, and double-end (Type 2 & 4), limited-movement types, or with lock coupled ends. Aggressive wear and pipe wall failure caused by fatigue of the convoluted surfaces present in rubber accordion or metal bellows types is eliminated with Dresser expansion joints. There is no need for expensive pipe loop systems.

Dresser expansion joints are built to order and are available up to 84" in diameter. Provided with rugged welded steel construction, the Style 63 is fabricated in carbon steel or can be custom-built in all stainless steel for special applications. Single-end expansion joints permit up to 10" of concentrated pipe movement. Larger amounts of movement are available upon request per application.

Packing seals include alternating rings of BUNA-S rubber and lubricated split jute. Special packing and lubrication requirements can be custom-matched to specific fluid processes or application requirements. Also other temperature ratings up to 800°F and pressure ratings to 1200 PSI are available.

Dresser ALCLAD™ epoxy coating is standard for optimum protection against aggressive water conditions and for handling brine, brackish water, coke oven gas, petroleum and other line content.



NSF61 and 372 Certified

Only products bearing the NSF Mark on the product, product packaging, and/or documentation shipped with the product are Certified.

Materials of Construction

Body & Tail Pipe	AISI C1006, C1010, C1015 or ASTM A513 Carbon Steel
Followers	AISI C1012, C1021, ASTM A20 OR A36 Carbon Steel
Bolts	ANSI/AWWA C111/ANSI A21.11. Black Ecoat
Slip Pipe	Chrome Plated
Packing	Alternating Rings of BUNA-S and Lubricated Split Jute
Coatings	Fusion-bonded Epoxy Dresser RED-D Shopcoat Optional

Style 63 Type 1 Sizes and Specifications

Pipe Nominal Size (in)	Outside Diameter (OD)	Bolts No./Diam. x Length (A&B)	Overall Dimensions		Weight Per Joint (lbs)
			Diam. (C)	Length (D) (E)	
3	3.500	4-5/8 x 11	8-1/2	CONSULT FACTORY PER ORDER	65
4	4.500	4-5/8 x 11	9-1/2		75
5	5.563	4-5/8 x 11	10-5/8		110
6	6.625	6-5/8 x 11	11-3/4		130
8	8.625	6-5/8 x 11	13-3/4		180
10	10.750	8-5/8 x 11	15-7/8		250
12	12.750	8-5/8 x 11	17-7/8		315
	14.000	8-5/8 x 11	19-1/2		340
	16.000	10-5/8 x 11	21-1/2		380
	18.000	10-5/8 x 11	23-1/2		415
	20.000	12-5/8 x 11	25-1/2		470
	22.000	14-5/8 x 11	27-1/2		525
	24.000	14-5/8 x 11	29-1/2	565	

Style 63 Type 3 Sizes and Specifications

Pipe Nominal Size (in)	Outside Diameter (OD)	Bolts No./Diam. x Length (A&B)	Overall Dimensions		Weight Per Joint (lbs)
			Diam. (C)	Length (D) (E)	
3	3.500	4-5/8 x 24	8-1/2	CONSULT FACTORY PER ORDER	80
4	4.500	4-5/8 x 24	9-1/2		90
5	5.563	4-5/8 x 24	10-5/8		125
6	6.625	6-5/8 x 24	11-3/4		155
8	8.625	6-5/8 x 24	13-3/4		205
10	10.750	8-5/8 x 24	15-7/8		285
12	12.750	8-5/8 x 24	17-7/8		350
	14.000	8-5/8 x 24	19-1/2		385
	16.000	10-5/8 x 24	21-1/2		430
	18.000	10-5/8 x 24	23-1/2		470
	20.000	12-5/8 x 24	25-1/2		530
	22.000	14-5/8 x 24	27-1/2		590
	24.000	14-5/8 x 24	29-1/2	635	

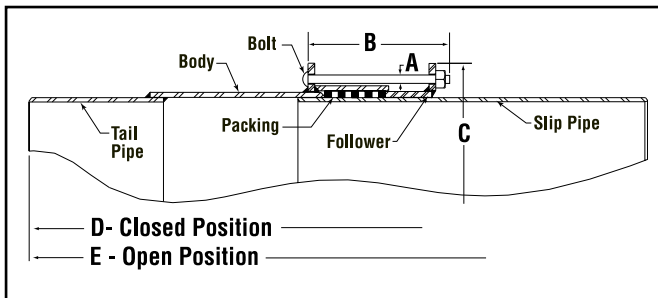

Type 1 is a single-end expansion joint permitting up to 10" of concentrated pipe movement. Standard packing consists of alternate layers of split resilient sealing rings and jute lubricating rings. Other packing for special conditions can be supplied.

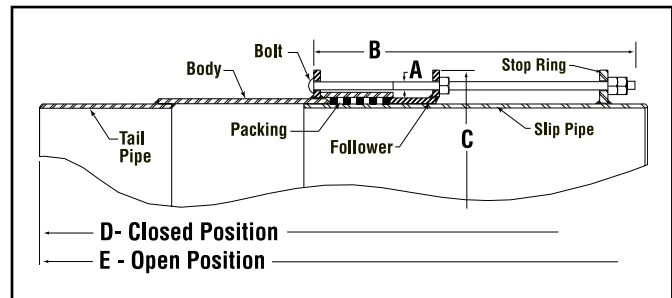

Type 3 is a single-end expansion joint equipped with a limited movement feature to limit the maximum amount of pipe withdrawal. Slip pipes are regularly furnished for Type 3 expansion joints.



Style 440 Joint Harnesses

Provides restraint and additional reinforcement of coupled joints

Dresser Style 440 Joint Harnesses are steel tie-bolts, diametrically opposite, which extend across a coupled joint from lugs welded to the pipe on either side of the joint. Joint harnesses are particularly effective on unanchored bends subject to pulsating pressures of sharp intensity.

Available as conductive or insulating, Dresser Joint Harnesses have been designed to meet DOT Regulation Part II, Section 192.273 and meet all safety requirements of modern distribution piping system practices. Weld lugs are made of rugged construction for optimum strength. Insulators are of high-quality thermoplastic resin compound providing minimum insulating rating of 5 meg-ohms at 100V, and will not short out.

A deflection ring placed behind one lug deflects to absorb contraction in connected pipes occurring after installation eliminating harmful stresses. Individual harnesses may be installed in the field as either insulated or conductive by simply interchanging parts.

Each Dresser Style 440 Joint Harness consists of two lugs, one deflection ring, one stud bolt and two nuts. Standard harnesses are furnished with either 5/8" or 3/4" stud bolts in lengths of 26" for 5" middle rings; 32" for 7" middle rings; and 44" for 12" & 16" middle rings. See pressure rating chart below with standard pipe OD's and quantity guidelines.

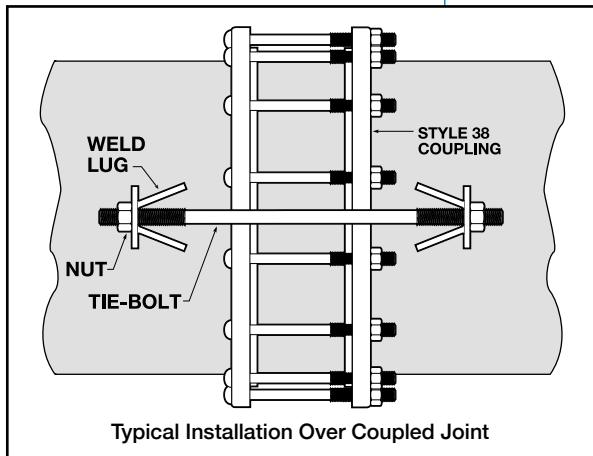

NOTE: Style 440 Joint Harnesses can be custom fabricated for special conditions with larger studs to reduce quantity and installation costs. Use of these products is limited and never required for ordinary conditions. Dresser engineers are glad to assist with project recommendations in all cases of unusual service conditions that may require these devices, and offer the most economical and practical solution for your particular pipe joint requirements.

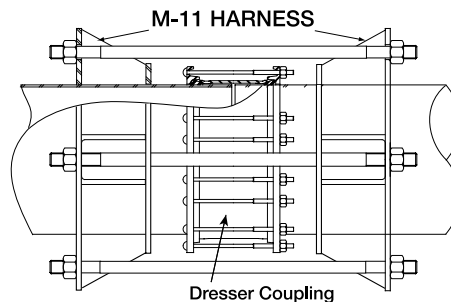

Custom-Built
AWWA M-11 Design
(Available Upon Request)

STYLE 440 SELECTOR CHART

Number of Joint Harnesses Required by Pipe Diameter, Bolt Size* and Working Pressure

Pipe Diam.	Bolt Size	Line Working Pressure (PSI)												
		25	50	75	100	125	150	175	200	225	250	275	300	
2" - 6"	5/8"	2	2	2	2	2	2	2	2	2	2	2	2	2
	5/8"	2	2	2	2	2	2	2	2	2	2	2	3	3
	3/4"	2	2	2	2	2	2	2	2	2	2	2	2	2
10"	5/8"	2	2	2	2	2	2	3	3	3	3	4	4	4
	3/4"	2	2	2	2	2	2	2	2	2	2	3	3	3
	5/8"	2	2	2	2	3	3	3	4	4	5	5	6	6
12"	5/8"	2	2	2	2	2	2	2	3	3	3	3	4	4
	3/4"	2	2	2	2	2	2	2	3	3	3	3	4	4
	5/8"	2	2	2	3	3	4	4	5	6	6	7	7	7
14"	5/8"	2	2	2	2	2	2	3	3	3	3	4	4	4
	3/4"	2	2	2	2	2	2	3	3	3	3	4	4	4
	5/8"	2	2	2	3	4	4	5	6	6	7	8	8	8
16"	5/8"	2	2	2	3	4	4	5	6	6	7	8	8	8
	3/4"	2	2	2	2	3	3	3	4	4	5	5	5	5
	5/8"	2	2	3	4	5	5	6	7	8	9	10	10	10
18"	5/8"	2	2	2	3	4	4	5	6	6	7	8	9	9
	3/4"	2	2	2	3	3	3	4	5	5	6	6	7	7
	5/8"	2	3	4	5	6	7	8	9	10	11	12	13	13
20"	5/8"	2	3	4	5	6	7	8	9	10	11	12	13	13
	3/4"	2	2	2	3	4	4	5	6	6	7	8	8	8
	5/8"	2	3	5	6	8	9	11	12	14	15	15	15	15
24"	5/8"	2	3	5	6	8	9	11	12	14	15	15	15	15
	3/4"	2	2	3	4	5	6	7	8	9	10	11	12	12
	5/8"	2	3	5	6	8	9	11	12	14	15	15	15	15
30"	3/4"	2	3	5	6	8	9	11	12	14	15	16	18	18
	3/4"	3	5	7	9	11	13	15	17	19	21	23	26	26
	3/4"	3	5	7	9	11	13	15	17	19	21	23	26	26

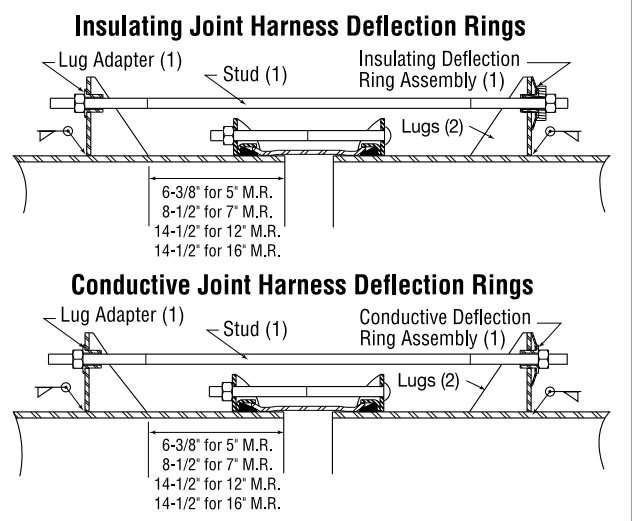

*BOLT SIZE - Larger bolt sizes and custom lugs are available to reduce quantity required. Consult factory with pipe OD and pressure rating.



For close-off, testing and capping 'dead-ends' for future branch extensions

Style 31 Line Caps

Dresser Style 31 Line Caps are used to close off sections of a pipeline during construction and testing, and to cap off dead-ends in the line for future branch connections. Style 31 Line Caps are made from Style 38 coupling parts with a convex steel dished head welded into one end of the middle ring. One follower ring is welded

to the cap itself, and only one gasket is required. Rated 150 PSI in all pipe sizes.

The Style 31 is regularly supplied with a 1" NPT vent and plug off-center. When ordering, please specify whether vent is to be provided. The Dresser Style 31 Line Cap is also available in an insulating design with insulating gasket, insulating

sleeve and pipe-end separator.

Style 31 Line Caps must NOT be used under pressure WITHOUT ANCHORAGE OR BLOCKING sufficient to withstand the entire longitudinal thrust due to internal pressure.

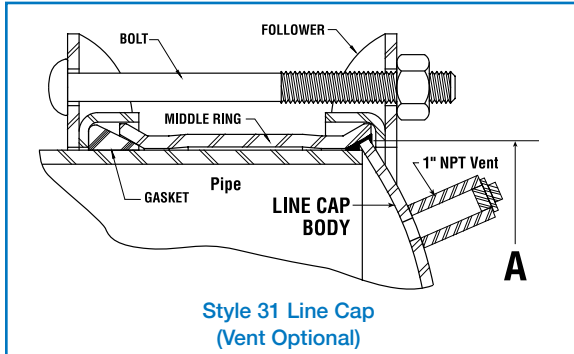

Style 31 Line Cap (Vent Optional)

Materials of Construction

Followers	AISI C1012 or ASME SA36
Middle Ring, End Cap	ASTM A513, ASTM A635 or ASME SA675 GR60; ASTM A536 Cast Ductile 3-6" Sizes
Bolts	AWWA C111/ANSI A21.11. Black Ecoat
Gasket	Armored Grade 27 BUNA-S
Coatings	Fusion-bonded Epoxy

NOTE: For 2" and 3" Style 31 Line Caps are supplied with 1" IPS vents in center of head as standard. 4" and larger are furnished with 1" IPS vent off-center (see photo above). Caps with no vents and caps with lock pins are available upon request. Consult factory for your particular requirements.

Style 31 Line Caps - 150 MAOP All Sizes

Specifications for Pipe Sizes 2" thru 24"

Pipe Nominal Size (in)	Outside Pipe Diameter (in)	Reference Dresser Part Number*	Body Ring Thickness x Length (in)	Bolts Quantity Diam/Length (in)	Dish Head Diameter (A) (in)	Approx. Weight Each (lbs)
2	2.375	0031-0001-202	.156 X 5	3- 5/8 x 4	2-3/4	11
3	3.500	0031-9004-202	.188 X 5	4- 5/8 x 4	3-3/16	12
4	4.500	0031-9108-202	.188 X 5	4- 5/8 x 4	4-7/8	18
4 CIP	4.800	0031-0109-203	.229 X 5	4- 5/8 x 6	5-1/4	19
6	6.625	0031-9111-202	1/4 X 5	6- 5/8 x 4	7-1/8	28
6 CIP	6.900	0128-9902-002	1/4 X 5	6- 5/8 x 6	7-11/32	27
8	8.625	0031-9114-202	3/8 X 5	6- 5/8 x 8-1/4	9	37
8 CIP	9.050	0031-0115-203	1/4 X 5	6- 5/8 x 8-1/4	19-1/2	45
10	10.750	0031-9117-202	3/8 X 5	8- 5/8 x 8-1/4	11-1/8	39
10 CIP	11.10	0031-0118-203	3/8 X 7	8- 5/8 x 8-1/4	11-5/8	71
12	12.750	0031-9120-202	3/8 X 5	8- 5/8 x 8-1/4	13-1/8	47
12 CIP	13.20	0031-0121-203	3/8 X 7	8- 5/8 x 8-3/4	13-11/16	100
14	14.00	0031-8123-202	3/8 X 7	10- 5/8 x 8-3/4	14-7/16	73
16	16.00	0031-8126-202	3/8 X 7	10- 5/8 x 8-3/4	16-7/16	94
16 CIP	17.40	0031-8220-204	3/8 X 7	10- 5/8 x 8-3/4	17-29/32	126
18	18.00	0031-8129-202	3/8 X 7	12- 5/8 x 8-3/4	18-7/16	98
24	24.00	0031-8223-202	3/8 X 7	15- 5/8 x 8-3/4	24-1/2	187
24 CIP	25.80	0031-8137-204	3/8 X 7	15- 5/8 x 8-3/4	26-5/16	230

*NOTE: GASKET - Part numbers listed include Armored Grade 27 BUNA-S gaskets. Consult factory for other pipe diameters not listed.

DRESSER Gasket Overview

Dresser Compounded Rubber Gaskets

Pipe joints must be able to absorb pipe stress caused by natural forces and allow for expansion, contraction, vibration and deflection while the line is in service.

The sealing capabilities and extreme flexibility of a Dresser coupled joint is made possible by the resilience of the rubber-compounded gaskets. Resiliency is the property that enables the gaskets to maintain pressure against the followers that confine it and, at the same time, allow for flexibility not found in rigid piping connections. Without it, a flexible joint is not possible! Simply put, the absorption of pipeline stress permits each section of the pipeline to “float” in the joint ensuring a flexible piping system. The information below is provided as a general review of various gaskets available when installing Dresser products.

Armored® Gaskets

Armored gaskets can be used to great advantage where low electrical-resistant joints are desired. The armor “bites” into the pipe providing metal to metal contact allowing easy passage of current where cathodic protection is a necessity.

The armor—an elastic, practically indestructible brass coil or helix—is molded into the gasket tip becoming an integral part of the gasket. When used with the proper grade/compound rubber, the armor shields the gasket material from the line content without interfering with the sealing efficiency of the gasket.

BUNA-S Grade 27 (Styrene) Max. Temp. 212°F¹

The compound most generally used for plain gaskets is BUNA-S. This gasket has wide applications and is accepted as standard for most pipeline use. It is recommended for use on lines transporting both fresh water and salt water, natural and other gases, air, most acids, alkaline and sugar solutions and some refrigerants.

BUNA-N Grade 42 (Nitrile) Max. Temp. 212°F¹

BUNA-N gaskets are resistant to oil, most aromatic and aliphatic hydrocarbons, natural gas fogging oil, condensates and gasoline.

Butyl - Max. Temp. 250°F; PSI to middle yield strength.

Butyl gaskets are resistant to hot air service, steam, hot water and miscellaneous aqueous solutions. They are also suitable for vegetable oils, organic chemicals, oxidizing acids and alkalies.

EPDM - Max. Temp. 300°F; MAX PSI: 250

EPDM gaskets provide excellent resistance to aging factors such as ozone, oxygen and elevated temperatures. This includes service in hot water, steam and dry heat. They are also suitable for handling popular chemicals such as ketones, alcohols, phosphate ester hydraulic fluids, glycols, vegetable oils, inorganic salt solutions, diluted acids and alkalies.

VITON* (Fluorocarbon) Max. Temp. 350°F; MAX PSI: 100

Fluorocarbon gaskets are resistant to hydrocarbons, aromatic hydrocarbons, alcohols, organic acids, nitrogen-containing compounds, vegetable oils and greases.

High Temperature - Max. Temp. 1200°F; NO PSI RATING

These braided, flexible gaskets are designed specifically for high temperature and abrasive atmospheres associated with services such as fly ash handling systems. As a replacement for asbestos, these gaskets are manufactured of a pure homogenous graphite bonded to a fiberglass carrier for strength and thermal durability. The braid over braid construction is die-formed and cut to length to fit proper coupling configurations resulting in a uniform tolerance which has proven itself as a reliable asbestos replacement.

Note: The non-resilient characteristic of this particular gasket material may result in a non leak-proof seal. This should be taken into consideration for this application.

¹NOTE: For Dresser Styles 65, 88 and 90 compression fittings, the maximum Temperature is 150°F

GASKET GRADE	TYPE RUBBER	MAXIMUM TEMP	MAXIMUM PSI	MOLD PAINT CODE	SHORE A DUROMETER
27 (Spec 35)	SBR - BUNA S	212°F ¹	Per Prod. Spec	White	75 ± 5
29 (Spec 328)	SBR - BUNA S	212°F	Per Prod. Spec	Light Green	70 ± 3
41	Natural	212°F	Per Prod. Spec	Dark Green	75 ± 5
42	BUNA N Nitrile	212°F ¹	Per Prod. Spec	Yellow	75 ± 5
169	Butyl	250°F	Per Prod. Spec	Blue	75 ± 5
199	EPDM	300°F	250 PSI	Light Gray	75 ± 5
224	Fluorocarbon (VITON*)	350°F	100 PSI	Brown/Tan	75 ± 5
316	Hi-Temp Graphite	1200°F	Limited Sealing	-	75 ± 5

WARNING: Temperature recommendations are for reference purposes only. Please consult Dresser Inside Sales for specific recommendations, product style, line content, working pressure and temperature ranges.

*VITON is a registered trademark of Dupont.

Other DRESSER Water Piping Products...



Style 38 ABS Type Couplings

Meets ABS Approval for Fire-Resistant Marine Couplings

Upon extensive independent testing, Dresser Style 38 couplings met the 2008 rule changes and received approval by the American Bureau of Shipping for fire rated couplings in marine applications. Typical applications for the ABS type approved Dresser coupling include above deck inert gas lines, cargo oil lines, bilge systems, fuel oil transfers, and lube oil transfer systems.

Each authentic Dresser approved coupling can be qualified to a working pressure of 275 PSI (19bar). Fire testing was successfully conducted to the stringent guidelines of ISO 19921 and 19922 requirements.

Dresser Pipeline Solutions has over 125 years experience manufacturing quality piping products and began supplying ABS approved couplings worldwide in 1942. Dresser couplings are widely used for marine piping systems for their ability to absorb vibration, expansion and contraction while providing leakproof dependability.

To prevent potential environmental incidents and help protect your investment, insist on using only authentic Dresser couplings for the quality and assurance you demand.



- Pipe Sizes 2" thru 32"
- Fire-Rated @ 275 PSI
- Fire-resistance tested to 2008 ABS Rules (ISO 19921 and 19922 Specifications)

Style 360 Repair Clamps

Style 360 Repair Clamps offer simplicity and ease of installation for the repair of holes, splits and cracks for permanent repair of Steel and Cast/Ductile Iron pipe. You can use it where pipe ends are separated, or where ends are deflected up to 4 degrees or 1/8 inch. Clamp features include a tapered gasket with a gridded design and the spanner molded into the gasket to prevent "hang up."

The "360" has a stainless band, lugs of rugged epoxy-coated ductile iron, special one-inch long nuts for use with a standard deep socket wrench, and bolts of corrosion-resistant Dresserloy (stainless steel optional).

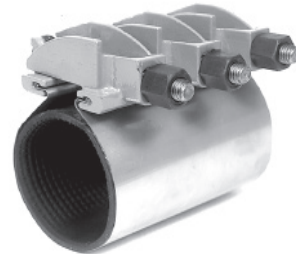

Applicable Bolted Steel Product Warnings

WARNING

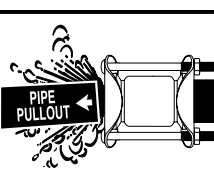

When pipe pullout could occur, pipe joint MUST be anchored. Failure to anchor pipe joint could result in escaping line content and cause property damage, serious injury or death.

WARNING

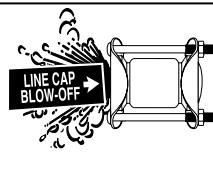

Style 31 Line Caps MUST NOT be used under pressure without anchorage or blocking sufficient to withstand the entire longitudinal thrust due to internal pressure. Failure to do so could allow line cap to blow off the line, causing serious injury or death. Also, escaping line content could cause property damage, serious injury or death!

Dresser Pipeline Solutions
41 Fisher Avenue
Bradford, PA 16701
T: 814.362.9200
F: 814.362.9344

© 2024 Natural Gas Solutions North America, LLC – All rights reserved. Dresser Utility Solutions reserves the right to make changes in specifications and features shown herein, or discontinue the product described at any time without notice or obligation. Contact your Dresser Utility Solutions representative for the most current information. The Dresser Logo and all Trademarks containing the term "Dresser" are the property of Dresser, LLC, a subsidiary of Baker Hughes.



Pipe Joining Water Products DPS.026b