

Series 4300

Electric Driven Injection Pump



Description

The series 4300 chemical injectors are electric motor driven, positive displacement pumps utilizing an integral worm gear drive available in three different standard ratios and 6 plunger sizes to provide a wide selection of volumes and pressures .063 GPD up to 325 GPD per head, against pressures from 150 to 5000 psig. An optional 10 to 1 gear reducer, mounted externally, is available for extra low pumping rates from 1-1/4 gallons per day down to 1/2 pint per day.

Pumps are standard with a micrometer type stroke adjustment that puts an end to the tedious work of stopping and starting the pump while trying to set the proper flow rate. A 0-100% change in capacity is possible while the pump is running. Each complete turn of the knob results in a 10% change in stroke setting. Repeatable accuracy is 1% of set point. Up to eight heads driven by a common motor are possible, and each head can be independently adjusted.

The standard, virtually trouble free packed plunger injector heads have built-in priming valves and a drip-ring type barrier that will prevent chemicals from being conducted along the plunger and into the gear box. Standard pumps can be furnished with high strength ductile iron or all stainless steel liquid ends to handle a wide variety of chemicals used in oil and gas production facilities, pipelines, process plants and other applications where a rugged, easy to maintain proportioning pump is required.

Features

- Integral gear drive and crosshead mechanism in heavy cast iron housing with an oil level sight gauge.
- Output gear of high strength alloy iron is supported in a sturdy special bearing arrangement for maximum rigidity to assure extremely long life.
- A special drip-ring feature on the plunger prevents chemical from being conducted into the gear box and contaminating the lubricant.
- Oil level gauge on gear box.
- A full gasket under the gear box cover provides a positive barrier against moisture, dirt, and corrosive vapors.
- Choice of liquid ends . . . all interchangeable.
- Multiplex models with up to 8 heads driven by a common motor are available.
- Stainless steel tanks
- Flow rate is adjustable while the pump is running.

Models available

the Texsteam 4300 Series pump is gear-driven and utilizes an electric motor, as a power source. Power units (less tank) and chemical injectors (with tank, suction piping and flow rate gauge) are available with from one to eight pumping heads in a choice of gear ratios (25:1, 50:1 or 100:1) and plunger sizes (3/16", 1/4", 3/8", 1/2", 3/4 or 1"). Refer to the chart below to determine horsepower requirements for units with multi heads.

Model designation:

4323-3-P 3/8"

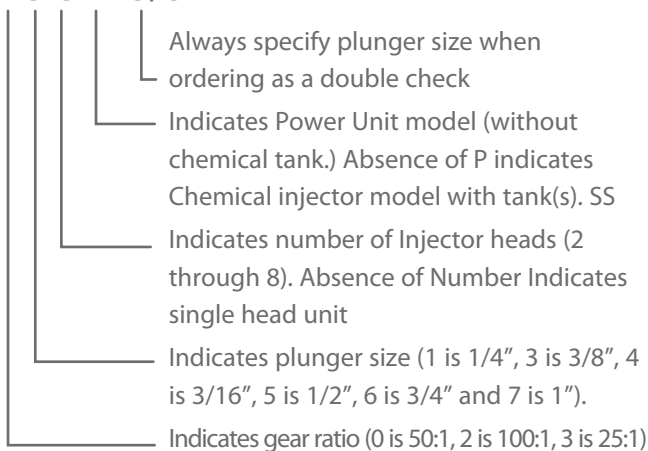

Horsepower Requirements for Multi-Headed Units

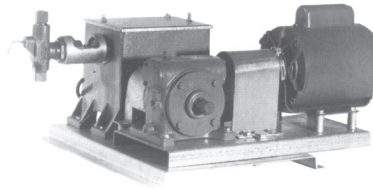
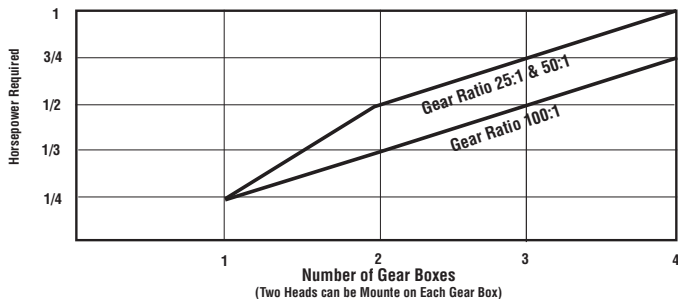

Single head power unit with 10:1 gear reducer for volumes down to 1/2 pint per day. Weight 90 pounds.

Single head power unit. Weight 70 pounds.

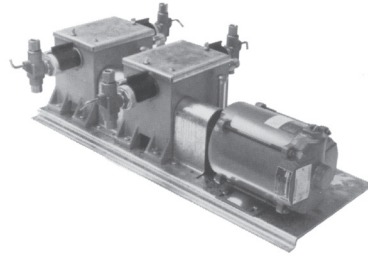
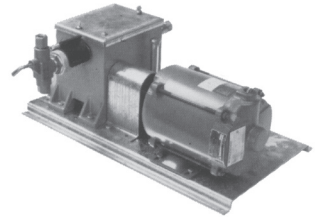

Four headed power Unit. Up to 8 head maximum available. Weight 120 pounds - 4 headed unit. 270 pounds - 6 headed unit

Double headed chemical injector with two 5 gallon SS tanks. Weight 110 pounds.

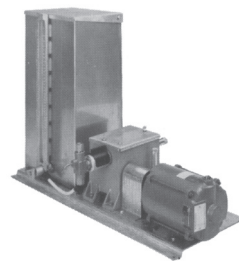
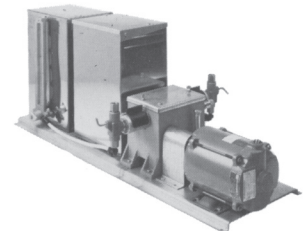

Single headed chemical injector with 10 gallon SS tank. Weight 105 pounds.

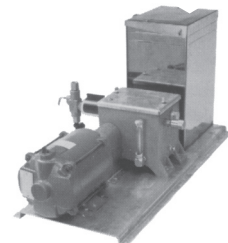

Single headed chemical injector with 5 gallon SS tank. Weight 90 pounds.

Plunger Size	Maximum Discharge Pressure	Min - Max Volume (Expressed in U.S. Gallons per day)											
		100:1 Ratio (17.5 SPM)			50:1 Ratio (35 SPM)			25:1 Ratio (70 SPM)					
		Model No.	Min.	Max GPD	Model No.	60 Hz Motor	50 Hz Motor	Model No.	60 Hz Motor	50 Hz Motor			
Single Head Units													
3/16"	5000 # Hard Pkg. 3000 # Soft Pkg.	4324	0.063	2.5	2.07	4304	0.13	5	4.15	4334	0.25	10	8.3
1/4"	2400 PSI	4321	0.5	5	4.15	4301	1	10	6.3	4331	2	20	16.6
3/8"	1200 PSI	4323	1.2	12	9.96	4303	2.3	23	19.09	4333	4.6	46	38.18
1/2"	600 PSI	4325	2.1	21	17.43	4305	4	40	33.2	4335	8	80	66.4
3/4"	300 PSI	4326	4.6	46	38	4306	9.1	91	75.5	4336	18.2	182	151
1"	150 PSI	4327	8.1	81	67.5	4307	16.3	163	135.2	4337	32.5	325	269.7
Double Headed Units													
3/16"	5000 # Hard Pkg. 3000 # Soft Pkg.	4324-2	0.13	5	4.14	4304-2	0.26	10	8.3	4334-2	0.5	20	16.6
1/4"	2400 PSI	4321-2	1	10	8.3	4301-2	2	20	16.6	4331-2	4	40	33.2
3/8"	1200 PSI	4323-2	2.4	24	19.9	4303-2	4.6	46	38.18	4333-2	9.2	92	76.4
1/2"	600 PSI	4325-2	4.2	42	34.86	4305-2	8	80	66.4	4335-2	16	160	132.8
3/4"	300 PSI	4326-2	9.2	92	76.3	4306-2	18.2	182	151	4336-2	36.4	364	302.1
1"	150 PSI	4327-2	16.2	162	134.4	4307-2	32.6	326	270.5	4337-2	65	650	539.5

Gear box shaft height is 3" from base to center line of shaft. If a Frame 48 Motor is used, four (4) TA-1741 shims are required. A Frame 56 Motor can be mounted on base without shims.

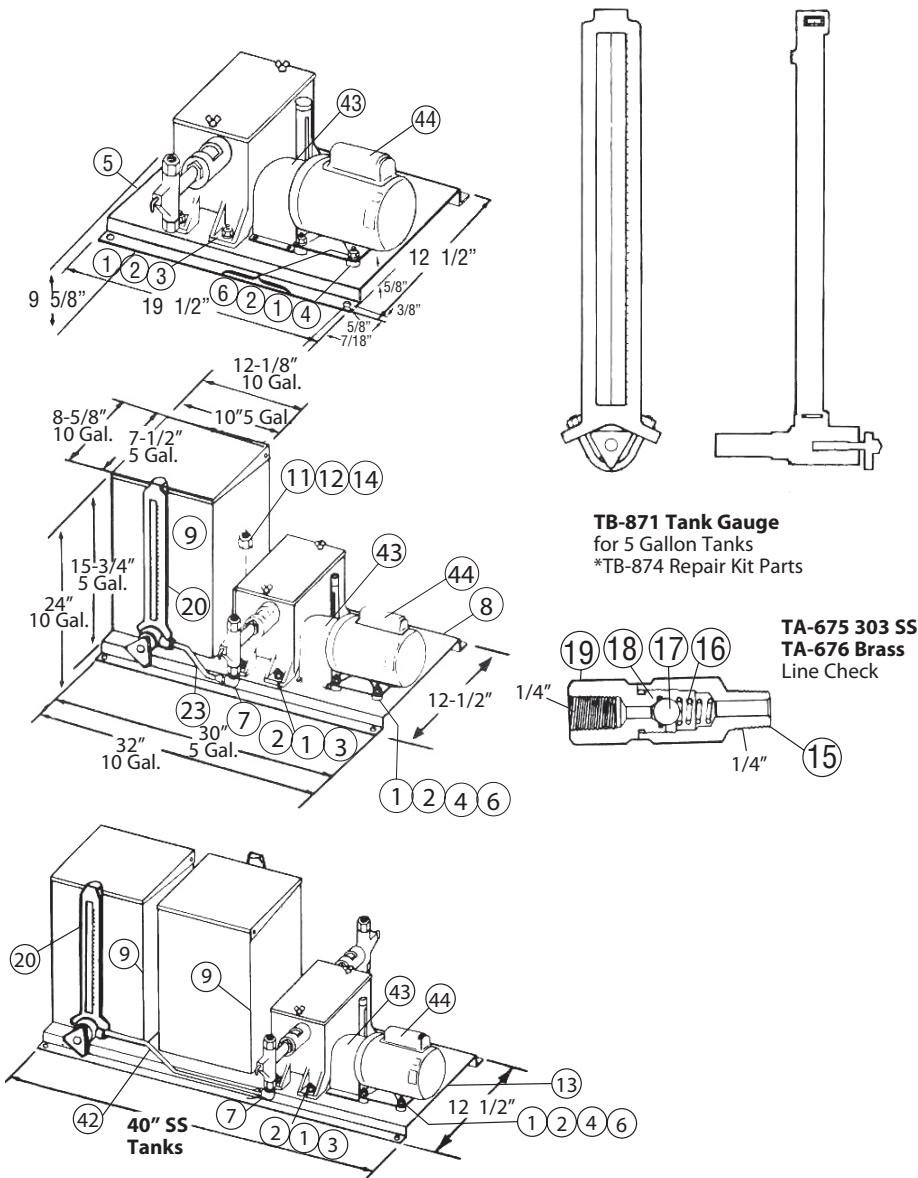

Item	Part No.	Part Name	Material
1	P25-025000-0200	Hex Nut	
2	P52-025000-3900	Lockwasher 1/4" Steel	
3	P53-025000-0200	Cut Washer	
5	TB-0437	Base 10 Gauge Galvanized Steel	
6	P01-025087-0200	Cap Screw	
7	TA-3116	Elbow & Compression Nut	
8	TB-0436	5 Gal. Tank & Pump Base	
	TC 2177	10 Gal. Tank & Pump Base	
9	TA-0664	5 Gal. Chemical Tank 430 SS	
	TA-1539	10 Gal. Chemical Tank 304 SS	
11	P52-031000-3900	Lockwasher	
12	P53-031000-0200	Cutwasher	
13	TB-0431	Base for two 5 Gal. SS Tanks	
14	P25-031000-3900	Hex Nut	
15	TA-0677	Brass Outer Body	
16	TA-0391	316 SS Spring	
17	TA-0054	316 SS Ball	
18	TA-0479	Buna N O-ring	
	TA-2580	Viton O-ring	
19	TA-0678	Brass Inlet Body	
20	TB-0871	5 Gal. SS Tank Gauge Assy.	
	TB-1285	10 Gal. Tank Gauge Assembly	
23	TA-3161	Polypropylene Tube	
42	TA-3162	Polypropylene Tube	
43	TB-1167	Coupling Guard	
44	TA-2264	1/4 HP, 1Ph, 60Hz, 115/230V, TEFC	
	TA-2268	1/4 HP, 3Ph, 60Hz, 230/460V, TEFC	
	TA-2265	1/4 HP, 1Ph, 60Hz, 115/230V, EX Proof	
	TA-2271	1/4 HP, 3Ph, 60Hz, 230/460V, EX Proof	

** Recommended Spare Parts
NOTE: All motors are 1800 RPM

Volumetric Conversion Factors			
cc/sec	x	0.95	= GPH
cc/min	x	0.016	= GPH
cc/hr	x	0.00026	= GPH
liters/sec	x	952	= GPH
liters/min	x	15.9	= GPH
liters/hr	x	0.264	= GPH
imperial GPM	x	72	= GPH
imperial GPH	x	1.2	= GPH
ml/sec	x	95	= GPH
ml/min	x	0.016	= GPH
ml/hr	x	0.00026	= GPH
m3/hr	x	264.2	= GPH

Pressure Conversion Factors			
KG/Sq CM	x	14.2	= PSIG
In. Hg	x	0.49	= PSIG
In. Water	x	0.036	= PSIG
Ft. of Water	x	0.43	= PSIG
Bars	x	14.7	= PSIG
kPa (kilo Pascal)	x	0.145	= PSIG
Mega Pa	x	145	= PSIG

Installation

1. Remove pump from carton and inspect for possible damage in transit from factory. The cardboard carton was designed especially for this pump. If the pump has been damaged in transit, file claim with the carrier.
2. Bolt holes are provided for a permanent mounting (see drawing for dimensions)
3. Remove the gear box lid and fill gear box with 1-1/2 quarts of a good grade of lubricant. The oil level should be maintained level with the top of the crosshead guide rods, item #24.
4. Adjust the stroke length to the desired volume. A full stroke length (1") will pump the maximum volume as shown in the data sheet. For approximately 50% volume use a 1/2" stroke, etc.
5. Connect the suction line to pump head
 - a. If a reservoir is furnished with the pump, the suction line is already connected. Fill the reservoir and open (all the way) the pump rate setting gauge valve, Item #35. A strainer is furnished as a part of this unit.
 - b. If a power unit model (without tank) was purchased, a strainer should be piped into the suction line to prevent sand, rust or other particles from injuring the plunger and fouling the check valves.
6. Connect the discharge line. A 1/4" line check is provided with all 3/16", 1/4", 3/8" & 1/2" heads. This valve should be installed as close to the point of injection as possible. Note the arrow on the check valve indicates the direction of flow. The top connection on the pump head is the outlet and has a 1/4" female pipe thread connection.
7. Mount motor if pump was ordered less motor. The pump input shaft speed should not exceed 1800 RPM and will operate the pump in either direction of rotation (CW or CCW). After careful alignment with shaft coupling (furnished on all pumps), bolt motor securely in place. Shaft alignment is very important. Misalignment will cause the bearings in the motor and pump as well as the coupling to wear out. Shim the motor if necessary. To check free rotation, turn motor and pump over by grasping the coupling and rotating. A minimum of 1/16" spacing should be allowed between coupling ends for expansion. The use of an overload protector in the motor circuit is recommended.

8. Install Item #16, priming valve (included with pump, but shipped loose in carton) on the pump head.
9. Start motor and prime the pump head by opening the priming valve. After the pump discharges fluid through the priming valve discharge without bubbles, slowly close the priming valve for normal operation. At this point make a visual check of the packing drip, and using the TA-315 gland wrench slowly tighten the gland to prevent excess drippage and waste of chemicals. Do not over-tighten plunger packing. It may be necessary to readjust the packing the next day. A slight leak during the break-in is beneficial, sufficient time should be allowed to let the packing "seat in". Do not tighten packing when pump head is under load. Discharge pressure should be atmospheric.

If low volumes are being pumped, the pump head, the discharge line, and all other fittings up to the line check should be thoroughly purged of all air bubbles.

Check pump action by opening the priming valve.

Operating instructions

1. Check oil level in gear box regularly. Observe oil level indicator, Item #5.
2. Check for excess chemical leakage around the packing gland. If it is impossible to tighten, replace the packing. If the plunger is badly scored, replace the plunger and packing. If excessive packing failure is experienced, consult your Texsteam representative.
3. Each Texsteam Series 4300 Pump has an adjustment for the required stroke length. To adjust stroke length see the FLOW RATE ADJUSTMENT instruction note on page 5.

Maintenance instructions

Replacing the stroke adjustment gears

When replacing the Nylon stroke adjustment gears, they have to be correctly positioned relative to the crosshead, the stroke adjustment knob, and to each other.

Rotate the motor coupling by hand until the crosshead, Item 2, is moved forward as far as it will go toward the side of the housing on which the head is mounted.

Assemble the small and large gears, Items 19 & 21, in place. Reference the illustrations on page 5. Leave the set screw, Item 23, in the large gear, loose for the time being. The two gears should be in mesh at this point, and rotating the large gear by hand will cause the small gear to move forward & back on the adjustment bolt, Item 16. Turn the large gear in the direction that causes the small gear to move forward toward the crosshead, and continue this turning motion until the small gear is flush up against the crosshead (no lost motion). Now turn the stroke adjustment knob, Item 55, clockwise until it covers the last groove on the spindle, then tighten Item 23, the set screw, in the large nylon gear, using a 5/64" Allen wrench.

The pump is now set in the full discharge stroke position, and all parts are in their correct relative positions. To make further adjustment in the flow rate, see the FLOW RATE ADJUSTMENT instruction about 1/3 the way down on page 5.

Disassembly of the power mechanism

1. Disconnect and remove pump head from power unit.
2. Remove item 21, large Nylon drive gear, by loosening Item 23, set screw with a 5/64" Allen wrench.
3. Remove Item 15 rod retainers and Item 14 "O" rings from each end of Item 24 bearing rods.
4. Using proper size punch, push bearing rods through Item 2 crosshead and out opposite side of gear box.

TO REMOVE ITEM #28 CROSSHEAD BEARING FROM WORM GEAR

Remove Item 2 crosshead and lift bearing off Item 27 bearing stud.

TO REMOVE WORM GEAR ITEM #37 AND ITEM #46 BEARING FROM GEAR BOX

1. Remove cap Item 36 from bottom of pump.

2. Remove Item 48 hex-head machine screw, Item 49 spring washer and Item 47 bottom thrust washer. You can remove the worm gear Item 37 and Item 46 bearing through the top of the housing Item 1.
3. Upon replacing be certain the gear roll pin Item 30 is located in its proper place — holding the bearing Item 46 in proper alignment.

TO REMOVE THE WORM GEAR AND SHAFT ITEM #12 SHAFT END REARING and/or OIL SEAL ITEM #9

It is not necessary to remove crosshead, guide rods or worm gear in order to remove the drive shaft and its component parts.

1. Disconnect flexible coupling and remove motor from base. If unit is equipped with container on base, it is best to remove entire gear box from base:
 - a. Remove Item 10 truarc ring
 - b. Remove Item 33 pipe plug (opposite side)
2. Insert proper size punch into recess on small end of Item 12 shaft (small end under Item 33 pipe plug). Carefully drive shaft out through opposite side of housing. Punch side should be small enough so not to drive against Item 3 inner race (if it is desirable to remove Item 4 needle bearing and Item 3 inner race, it should be done after the shaft has been removed).

As the shaft is being driven out, care should be taken to see that the large worm gear turns. This will "walk" or disengage the gear teeth.

As the shaft emerges from the side of housing, it will force out the oil seal Item 9, seal cartridge Item 11 and ball bearing Item 7. Withdraw the shaft from pump housing.

In order to remove ball bearing Item 7 from shaft, it is necessary to remove one or both truarc rings Item 6.

Upon replacing, care should be taken to "walk" the two worm gears back together.

Be sure the two truarc rings Item 6 are in place and that seal and seal housing are in properly (the seal lips and seal expander spring should face into the pump). Make sure the "O" ring Item 8 is in its proper place. The shaft assembly should be inserted into the pump until shaft bearing Item 7 shoulders against the truarc ring Item 10 located near the inner edge of the hole into which the shaft is inserted.

Gear box assembly

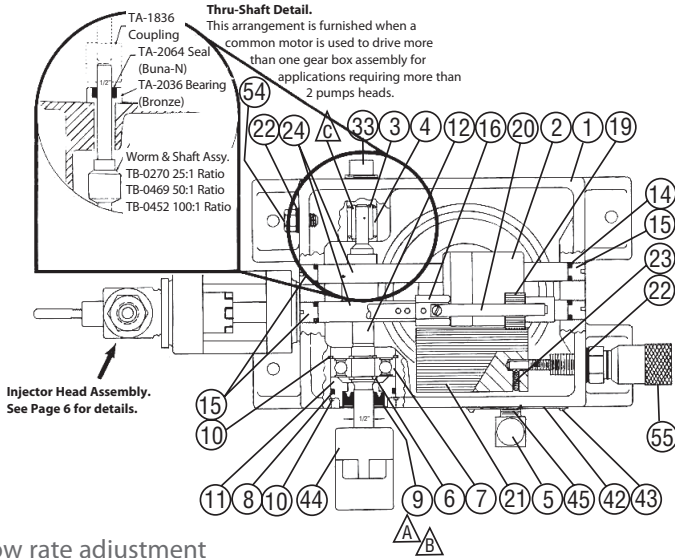

Flow rate adjustment

Turn knob, Item no. 55, clockwise to decrease flow; counterclockwise to increase flow. Each complete turn of the knob results in 10% change in stroke setting. Each groove on the spindle, Item number 56, is equal to 25% change in stroke setting. To adjust pump while stopped, make sure plunger is in the full forward position.

Maximum stroke length is 1".

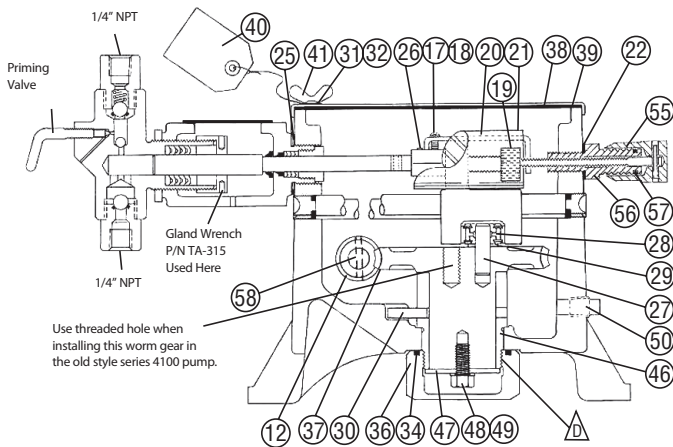

* Recommended spare parts

** Item 44-alternate coupling for 48 frame TA-1836 1/2" x 1/2"

These parts are directly interchangeable with Series 4100 and 4200 pumps.

Apply Lubriplate 630 AA to wear surfaces of the following items:

- Guide & Crosshead Bearing Rod surfaces in contact with Crosshead.
- Worm Teeth & Gear Teeth. Seal Cartridge (Item 11). Worm Gear in contact with Lower Bearing (Item 46). Thrust Washer (Item 47). Surface in contact with Lower Bearing (Item 46).

Apply Lubriplate 631 PA or equal between Shaft & Seal lips.

Assemble Oil Seal flush with end of Cartridge.

Apply Lubriplate 630 AA or equal.

Use Locktite on threads.

Parts list

Item	Part Number	No. Reqd.	Name	Material
1	TD-0492	1	Housing	Cast Iron
2	TB-1333	1	Crosshead	Cast Iron
3*	TA-2287	1	Inter Race Bearing	Carbon Steel
4*	TA-2286	1	Needle Bearing	Carbon Steel
5	TA-4066	1	Oil Gauge Assembly	Brass w/ Glass Tube
6	TA-3310	2	Truarc Ring	Carbon Steel
7*	TA-2285	1	Ball Bearing	Carbon Steel
8*	TA-1961	1	O-ring	Buna-N
9*	TA-2064	1	Seal	Buna-N
10	TA-3311	2	Truarc Ring	Carbon Steel
11*	TA-4045	1	Cartridge Seal	Carbon Steel
12	TA-1871	1	Worm & Shaft Assy (25:1 Ratio)	Carbon Steel
	TA-2250	1	Worm & Shaft Assy (50:1 Ratio)	Carbon Steel
	TA-1755	1	Worm & Shaft Assy (100:1 Ratio)	Carbon Steel
13	P61-075000-2800	1	Pipe Plug	Cast Iron
14*	TA-3849	4	O-ring	Buna-N
15	TA-4228	4	Retainer Rod	Carbon Steel
16	TA-4755	1	Adjustment Bolt	Carbon Steel
17	P52-N08000-3900	1	Lockwasher	Steel Cad Plated
18	P08-N08062-3900	1	Round Head Screw	Steel Cad Plated
19	TA-4757	1	Stroke Adjustment Gear	Nylon
20	TA-4756	1	Guide Bar	304 SS
21	TA-4758	1	Stroke Adjmt Drive Gear	Nylon
22	TA-4759	2	Gasket	Buna-N
23	P20-N10050-3900	1	Set Strew	Steel
24	TA-4229	2	Crosshead Guide Rod	Carbon Steel
25	TA-4256	2	Belleville Washer	302 SS
26	TA-0290	1	Plunger Pin	Carbon Steel
27	TA-4064	1	Bearing Stud	Carbon Steel
28*	TA-4065	1	Crosshead Bearing	Carbon Steel
29	P55-043000-0200	1	Washer	Carbon Steel
30	TA-2337	1	Roll Pin	Carbon Steel Cad Plated
31*	TA-4092	2	1/4" Stat-O-Seal	Buna-N
32*	TA-4093	2	1/4" Gaskets	Neoprene
33	TA-3309	1	Pipe Plug	Malleable Iron Galvanized
34*	TA-2457	1	O-ring	Buna-N
36	TA-1921	1	Cap	Ductile Iron
37	TB-621	1	Worm Gear (25:1 Ratio)	Cast Iron
	TB-616	1	Worm Gear (50:1 Ratio)	Cast Iron
	TB-623	1	Worm Gear (100:1 Ratio)	Cast Iron
38	TA-4814	1	Cover Gasket	Neoprene
39	TC-1576	1	Cover	Carbon Steel Galvanized
40	TA-1656	1	Lubrication Instructions	Paper Tag
41	P86-025100-0200	2	Wing Screw	Carbon Steel Cad Plated
42	GA-3181	1	Name Plate	304 SS
43	P43-N02018-3900	2	Escutcheon Pin	Brass
44**	TA-1653	1	1/2" x 5/8" Coupling (56 frame motor)	TA-1836 1/2" x 1/2"
45	TA-3325	1	1/4" Nipple	Carbon Steel Cad Plated
46	TB-619	1	Lower Bearing	Ductile Iron
47	TA-1930	1	Bottom Thrust Washer	Carbon Steel
48	P01-037062-3900	1	Machine Screw	Carbon Steel
49	P52-037000-3900	1	3/8" Spring Lockwasher	Carbon Steel
50	P61-025000-8000	1	Pipe Plug	Malleable Iron Galvanized
51	See Pg. 6		Injector Heads	
54	P02-050050-1600	1	Bolt	Steel Cad Plated
55	TA-4805	1	Stroke Adjmt Knob & Screw Ass'y	Steel
56	TA-4761	1	Stroke neat Spindle	303 SS
57	TA-2116	1	O-ring	Buna-N
58	TA-2351	1	Roll Pin	Carbon Steel

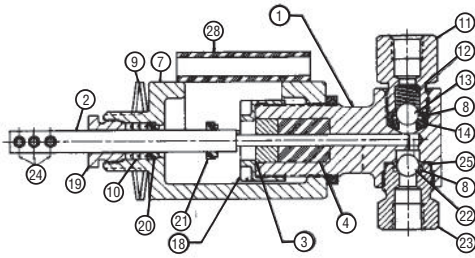

3/16" Head

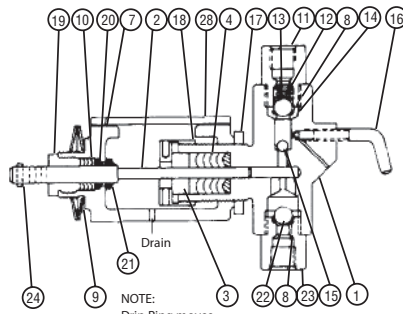

1/4"-3/8" - 1/2" Heads

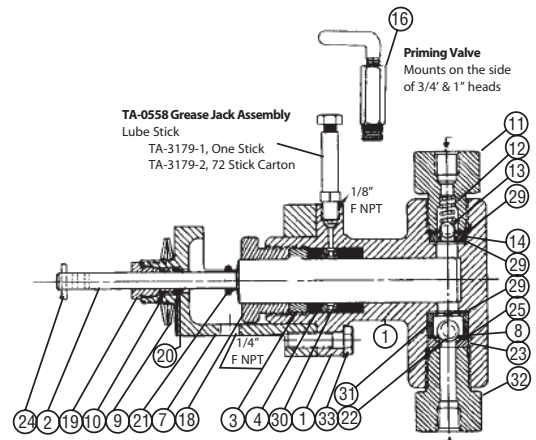

3/4" - 1" Heads

Parts List

Plunger Size/Model #			3/16"	1/4"		3/8"		1/2"		3/4"		1"	
Item No.	Part Name Trim	Material Specification Trim	All SS Trim	Ductile Iron w/SS Trim	All SS Steel	Ductile Iron w/SS Trim	All w/SS Steel	Ductile Iron w/SS Trim	All w/SS Steel	Ductile Iron w/SS Trim	All w/SS	Ductile Iron w/SS	All SS Steel
Head Assembly Number			TC-2041	TC-1578	TC-1582	TC-1579	TC-1583	TC-1580	TC-1584	TC-1888	TC-1887	TC-1886	TC-1885
1	Body		TC-2040	TC-0275	TC-0291	TC-0276	TC-0425	TC-0272	TC-0349	TC-0333	TC-0340	TC-0020	TC-0138
2*	Plunger	17-4PH SS	TB-1471	TB-1175	TB-1175	TB-1176	TB-1176	TB-1177	TB-1177	TB-1351	TB-1351	TB-1352	TB-1352
3	Plunger Packing Gland	303 SS	TA-5642	TA-1463	TA-1463	TA-0957	TA-0957	TA-1219	TA-1219	TA-2769	TA-2769	TA-0043	TA-0043
4*	Plunger Packing Set (Buna N)	Buna-N	TA-3969	TA-1461	TA-1461	TA-1456	TA-1456	TA-0959	TA-0959	TA-2771	TA-2771	TA-0050	TA-0050
7	Yoke	Malleable Iron	TB-1173	TB-1173	TB-1173	TB-1173	TB-1173	TB-1173	TB-1173	TC 1884	TC 1884	TC 1884	TC 1884
8	O-Ring (Included in item 23)	Buna-N	TA-0479	TA-0479	TA-0479	TA-0479	TA-0479	TA-0479	TA-0479	TA-0612	TA-0612	TA-0612	TA-0612
9	Belleville Washer (2 Req'd)	C. Steel	TA-4256	TA-4256	TA-4256	TA-4256	TA-4256	TA-4256	TA-4256	TA-4256	TA-4256	TA-4256	TA-4256
10*	Yoke Packing Set	Buna-N	TA 4127	TA-4127	TA-4127	TA-4127	TA-4127	TA-4127	TA-4127	TA-4127	TA-4127	TA-4127	TA-4127
11	Top Bushing	302 SS	TA-1496	TA-1496	TA-1496	TA-1496	TA-1496	TA-1496	TA-1496	TA-0152	TA-0152	TA-0152	TA-0152
12*	Ball Check Spring	316 SS	TA-0077	TA-0077	TA-0077	TA-0077	TA-0077	TA-0077	TA-0077	TA-0077	TA-0077	TA-0077	TA-0077
13*	Large Top Ball 3/8"	316 SS	TA-0054	TA-0054	TA-0054	TA-0054	TA-0054	TA-0054	TA-0054	TA-0054	TA-0054	TA-0054	TA-0054
14*	Top Seat-Assembly w/ Buna-N "O"-ring	303 SS	TB-0737	TB-0737	TB-0737	TB-0737	TB-0737	TB-0737	TB-0737	TB-0368	TB-0368	TB-0368	TB-0368
15*	Small Top Ball 1/4"	316 SS	TA-0126	TA-0126	TA-0126	TA-0126	TA-0126	TA-0126	TA-0126	N/A	N/A	N/A	N/A
16	Priming Valve (Ball & Spring incl. 3/16")	303 SS	TA-5462	TA-1497	TA-1497	TA-1497	TA-1497	TA-1497	TA-1497	TA-0123	TA-0123	TA-0123	TA-0123
17	Yoke Lock Nut	Brass	TA-0225	TA-0225	TA-0225	TA-0225	TA-0225	TA-0225	TA-0225	N/A	N/A	N/A	N/A
18	Nut, Plunger Packing Gland	303 SS	TA-4104	TA-4104	TA-4104	TA-4104	TA-4104	TA-4104	TA-4104	TA-2768	TA-2768	TA-0047	TA-0047
19	Yoke Packing Nut	Brass	TA-4094	TA-4094	TA-4094	TA-4094	TA-4094	TA-4094	TA-4094	TA-4094	TA-4094	TA-4094	TA-4094
20*	Plunger Wiper Ring	Buna N	TA-4095	TA-4095	TA-4095	TA-4095	TA-4095	TA-4095	TA-4095	TA-4095	TA-4095	TA-4095	TA-4095
21	Plunger Drip Ring	Buna N	TA-4095	TA-4095	TA-4095	TA-4095	TA-4095	TA-4095	TA-4095	TA-4095	TA-4095	TA-4095	TA-4095
22*	Suction Ball 3/8" Ø 1/2" 3/4" & 1" Head	316 SS	TA-0054	TA-0054	TA-0054	TA-0054	TA-0054	TA-0054	TA-0054	TA-0053	TA-0053	TA-0053	TA-0053
23*	Bottom Seat w/Buna n O-ring	303 SS	TB-1216	TB-0736	TB-0736	TB-0736	TB-0736	TB-0736	TB-0736	TB-0698	TB-0698	TB-0698	TB-0698
24	Plunger Pin	Carbon Steel	TA-0290	TA-0290	TA-0290	TA-0290	TA-0290	TA-0290	TA-0290	TA-0290	TA-0290	TA-0290	TA-0290
25	Gasket	304 SS	TA-4394	N/A	N/A	N/A	N/A	N/A	N/A	TA-2338	TA-2338	TA-2338	TA-2338
26*	O-Ring	Buna-N	TA 0479	TA 0479	TA 0479	TA 0479	TA 0479	TA 0479	TA 0479	TA 2097	TA 2097	TA 2097	TA 2097
27*	O-Ring	Buna-N	TA 3230	TA 3230	TA 3230	TA 3230	TA 3230	TA 3230	TA 3230	TA 0612	TA 0612	TA 0612	TA 0612
28	Yoke Cover	Plastic	TC-1604	TC-1604	TC-1604	TC-1604	TC-1604	TC-1604	TC-1604	N/A	N/A	N/A	N/A
29	Gasket (3 Req'd)	Tern Plate	N/A	N/A	N/A	N/A	N/A	N/A	N/A	TA-2350	TA-2350	TA-2350	TA-2350
30*	Lantern ring	303 SS	N/A	N/A	N/A	N/A	N/A	N/A	N/A	TA-2770	TA-2770	TA-0448	TA-0448
31	Ball Cage	303 SS	N/A	N/A	N/A	N/A	N/A	N/A	N/A	TA-0444	TA-0444	TA-0444	TA-0444
32	Bottom Bushing	303 SS	TB 1213	TB 0735	TB 0735	TB 0735	TB 0735	TB 0735	TB 0735	TA-0153	TA-0153	TA-0153	TA-0153
33	Bolt	303 SS1	N/A	N/A	N/A	N/A	N/A	N/A	N/A	TA-4452	TA-4452	TA-4452	TA-4452
Alternative Parts for Corrosive Service													
4*	Plunger Packing	Viton 2400# Max.	TA-3967	TA-4102	TA-4102	TA-4101	TA-4101	TA-4103	TA-4103	TA-4657	TA-4657	TA-4658	TA-4658
		Teflon 1000# Max.	TA-3966	TA-1642	TA-1642	TA-1234	TA-1234	TA-1012	TA-1012	TA-2988	TA-298	TA-1013	TA-1013
		Hard 5000# Max.	TA-3948	TA-2295	TA-2295	TA-1875	TA-1875	TA-1874	TA-1874	TA-2772	TA-2772	TA-4135	TA-4135
8*	O-Ring	Viton	TA-2580	TA-2580	TA-2580	TA-2580	TA-2580	TA-2580	TA-2580	TA-2184	TA-2184	TA-2184	TA-2184
14*	Top Seat Assy. (M-to-M)	303 SS	N/A	TA-0806	TA-0806	TA-0806	TA-0806	TA-0806	TA-0806	TA-0157	TA-0157	TA-0157	TA-0157
22*	Ball 1/2" (Use w/ TA-0771, M-to-M Bottom Seat Only)	316 SS	N/A	TA-0053	TA-0053	TA-0053	TA-0053	TA-0053	TA-0053	TA 0053	TA 0053	TA 0053	TA 0053
23*	Bottom Seat (M-to-M)	303 SS	N/A	TA-0771	TA-0771	TA-0771	TA-0771	TA-0771	TA-0771	TA 0051	TA 0051	TA 0051	TA 0051

*Recommended Spare Parts

Texsteam Pumps

16240 Port Northwest Drive

Houston, TX 77041

T: 832-590-2306

Toll Free: 1-800-945-9898

F: 713-849-2879

© 2021 Natural Gas Solutions North America, LLC – All rights reserved. Dresser Utility Solutions reserves the right to make changes in specifications and features shown herein, or discontinue the product described at any time without notice or obligation. Contact your Dresser Utility Solutions representative for the most current information. The Dresser Logo and all Trademarks containing the term "Dresser" are the property of Dresser, LLC, a subsidiary of Baker Hughes.



www.dresserutility.com

Texsteam Series 4300 IOM NGS.IPG.0057a

08.21