

Series 5100

Gas/Pneumatic Driven Injection Pump

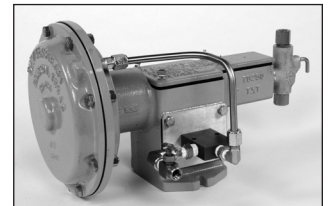
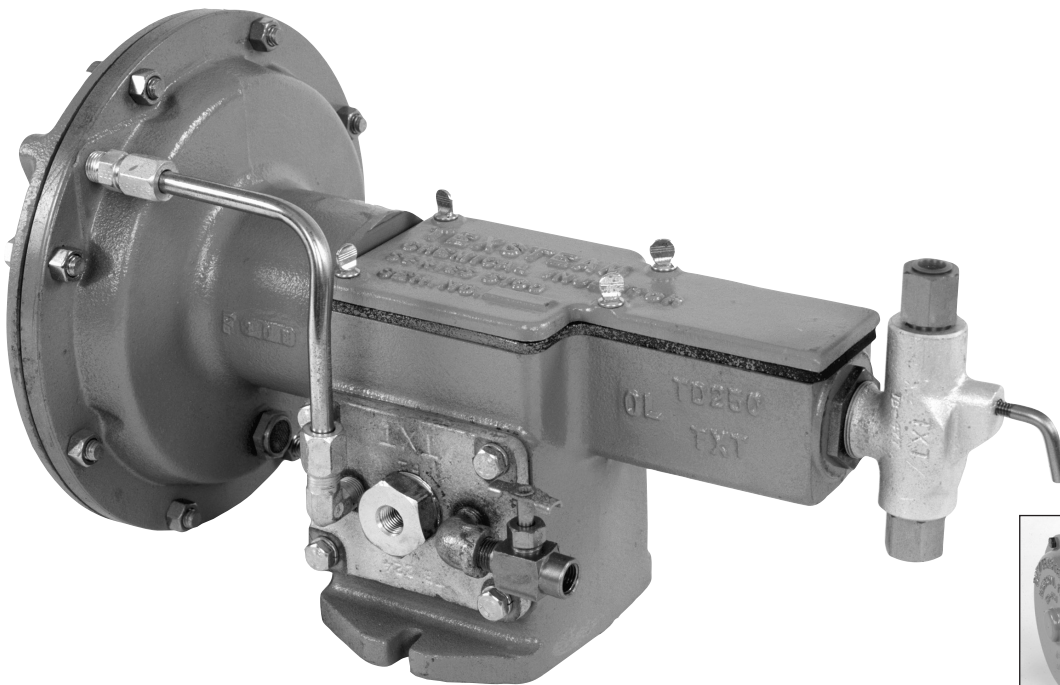

CONTENTS

Description	1
Applications	1
Accessories, Options, and Volume	2
Gas Consumption Chart	2
Installation	3
Important	3
Start Up and Operation	3
Maintenance	4
LP and HP	5
Parts List	5
Parts List	6
Pilot Valve Assembly	7
Parts List	7
Injector Heads	8
5100 Microswitch Valve Installation	9
Installation	9
Microswitch Valve Replacement	12

Description

The Texsteam 5100 Series Chemical Injectors from Texsteam Pumps are single acting, positive displacement plunger-type pumps, powered by gas via a diaphragm with a spring return. Speed control is accomplished by regulating the exhaust gas discharge flow. Reversal is accomplished by a direct spring- actuated switching mechanism (rotary three-way valve). Volume is controlled by the speed of the pump and by the stroke length, either 1" or 1/3" (25.4mm or 8.5mm) lengths.

The 5100 Series is capable of pumping high pressures with gas pressure as low as 8 psig (0.6 bar) and handling volume output up to 30 GPD (113.6 LPD).

The pump is lightweight, compact and contains a minimum of working parts for easy maintenance. Each fluid pump head is equipped with a stainless steel plunger, ball checks, ball check springs, top seat, top bushing, bottom bushing, adjustable VEE type packing and a priming valve. The packing yoke is equipped with a drain to monitor for possible packing leaks. Because of the sealed bearings, the unit is oil-less.

The 5100 Series performs accurately because: (1) the head is designed for high volumetric efficiency; (2) a positive trip mechanism assures fine control of plunger stroke length; and (3) the speed is regulated by controlling the exhaust gas discharge flow which creates a rapid fluid discharge with slow suction.

Applications

- The introduction of de-emulsifiers, solvents, corrosion inhibitors, de-salting agents and flocculants in oil country operation
- High pressure bearing lubrication
- Water treatment
- Blending processes in refining and process plants
- Injection of methanol in gas pipelines
- Hydrostatic testing
- Sampling

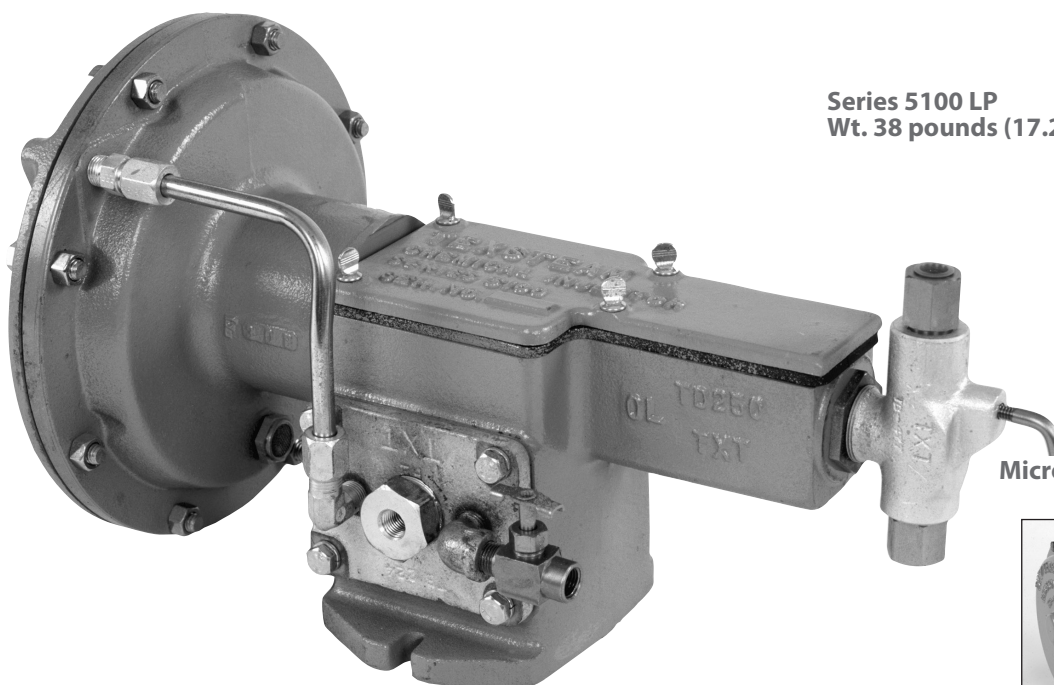

Series 5100 LP
Wt. 38 pounds (17.2 Kg)

Microswitch Option Available

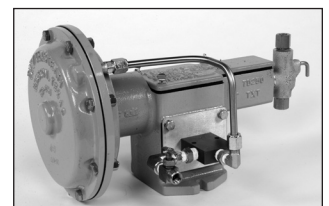

Accessories, Options, and Volume

Sour Gas Trim – Pump Models L and LP are furnished with sour gas trim as standard. Models H and HP are available for sour gas service specification.

TB-40 Regulator – for inlet gas pressure greater than 35 psig (2.4 bar) and up to 1500 psig (103.4 bar)

Alternate Parts – Teflon™, Viton™, or fluorosilicone packing, hastelloy balls.

Plunger Size	Maximum Discharge Pressure (PSIG/BAR)	GPD = gallons per day LPD = liters per day For Operation Off Air or Gas Pressure to 35 PSIG (2.4 BAR) Constant Power Unit ¹	
5100 Series (Standard Packing)		Model Number	Maximum Volume (GPD/LPD)
3/16" (4.8mm)	1500/103.4	5104	4.2/15.9
1/4" (6.4mm)	1500/103.4	5101	7.5/28.4
3/8" (9.5mm)	1500/103.4	5103	16.8/63.6
1/2" (12.7mm)	1500/103.4	5105	32.0/121.1
(High Pressure Packing)		Model Number	Maximum Volume (GPD/LPD)
3/16" (4.8mm)	6000/413.7	5104	2.8/10.6
1/4" (6.4mm)	6000/413.7	5101	5.0/18.9
3/8" (9.5mm)	6000/413.7	5103	12.0/45.4
1/2" (12.7mm)	3500/241.3	5105	22.0/83.3

1. Basic pump no tank, base, regulator, gauge (Shipping Weight: 45 lbs (20.4 Kg).)
2. Furnished with 5 gallon (18.9 L) stainless steel tank mounted on heavy galvanized steel base and equipped with level gauge and suction line but no regulator or gauge (Shipping Weight: 60 lbs (27.2 Kg).)
3. Furnished with regulator and gauge but no tank or base (Shipping Weight: 48 lbs (21.8 Kg).)

4. Furnished with 5 gallon (18.9 L) stainless steel tank mounted on heavy galvanized steel base and equipped with level gauge, suction line, regulator and gauge (Shipping Weight: 62 lbs (28.1 Kg).)

¹ Volumes shown for low pressure heads with standard packing are at zero psig (zero bar) discharge pressure.

² Volumes For high pressure head with hard packing are shown at 1500 psig (103.4 bar) discharge pressure.

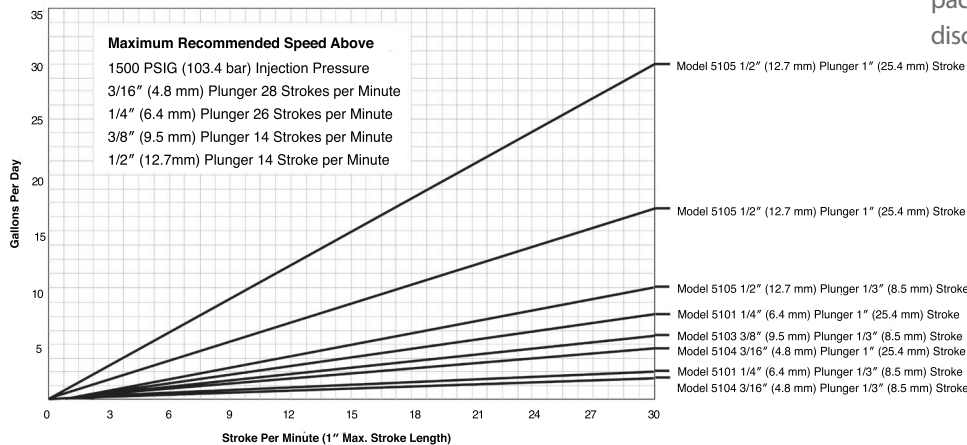

Gas Consumption Chart

(Standard Cubic Feet of Gas Required to Pump 1 Gallon/3.8L)

For inlet regulator sizing, double the requirement indicated

Injection Press in PSIG		100	200	500	1000	1500	2000	3000	3500	4000	5000	6000
Injection Press in BAR		6.9	13.8	34.5	68.9	103.4	137.9	206.8	241.3	275.8	344.7	413.7
1/2" (12.7mm) Plunger 1" Stroke (25.4mm)	5105	53	54	57	62	71	76	84	95			
1/2" (12.7mm) Plunger 1/3" Stroke (8.5mm)		159	162	171	186	213	228	252	285			
3/8" (9.5mm) Plunger 1" Stroke (25.4mm)	5103	120	126	148	164	177	185	243	278	314	355	374
3/8" (9.5mm) Plunger 1/3" Stroke (8.5mm)		360	378	444	492	531	555	729	834	942	1065	1122
1/4" (6.4mm) Plunger 1" Stroke (25.4mm)	5101	244	245	248	270	288	308	340	355	369	405	497
1/4" (6.4mm) Plunger 1/3" Stroke (8.5mm)		732	735	744	810	864	924	1020	1065	1107	1215	1491
3/16" (4.8mm) Plunger 1" Stroke (25.4mm)	5104	457	458	462	469	476	530	545	555	560	575	589
3/16" (4.8mm) Plunger 1/3" Stroke (8.5mm)		1371	1374	1386	1407	1428	1590	1635	1665	1680	1725	1776

Installation

⚠ WARNING—The transported medium and supply gas shall not be warmer than 100°C.

Max. Gas Diaphragm Chamber Pressure 35 psig (2.4 bar)

Important

The pump is to be operated outdoors. Otherwise, it should be operated in a ventilated area with reliable ventilation which has a rating of no less than IPL1 (Ignition Protection Level 1).

1. Remove pump from carton and inspect for possible damage in transit from factory. The cardboard carton was designed especially for this pump and offers ample protection for normal handling. If the pump has been damaged in transit, file claim with the carrier.

2. Position pump in desired location in accordance with all local safety codes and regulations and secure in place with fastening hardware through each of the two slots on the feet of the base.

If a model with a base plate has been ordered, pump will be secured to the base plate with a 5/16" (7.9mm) x 1 - 1/4" (31.75 mm) bolt, 5/16" (7.9mm) washer, 5/16" (7.9mm) lock washer, and 5/16" (7.9mm) nut through each of the two slots in the feet of the base. Additional measures should be taken by the end user to further secure the assembly in place in accordance with all local safety codes and regulations.

3. Loosen and remove the four thumb screws that hold the cover.

4. Select the stroke length desired, either full or short according to your requirements. See the data chart, full stroke is 1" (25.4mm) and short stroke is equal to 1/3" (8.5mm).

5. Check plunger packing gland to make sure packing is 1/4 turn past finger tight.

6. Install the priming valve TA-1497 in its position on the pump head.

7. Blow or clean line before hooking up air or gas line to inlet. On Models 5100 LP and 5100 L the air or gas line [if it does not exceed 35 psig (2.4 bar)] is piped directly into the inlet TA-906. The inlet is a 1/4" (8mm) female connection. Do not hook up the gas supply to the small valve. This is the gas exhaust. Gas supply should be constant pressure to assure even stroke speed.

If the gas supply pressure exceeds 35 psig (2.4 bar) or is erratic, some means of reducing the gas pressure to below 35 psig (2.4 bar) must be used. Models 5100 HP and 5100 H are equipped with a pressure regulator and pressure gauge for reducing the gas pressure. The regulator supplied with the 5100 HP and 5100 H can be used up

400 psig (27.5 bar) . If the gas supply pressure exceeds 400 psig (27.5 bar) , the customer should equip the pump with a Texsteam TB-40 regulator which has a maximum inlet pressure of 1500 psig (103.4 bar)

8. Close gas exhaust valve. The gas exhaust is a 1/4" (8mm) female pipe connection.

9. Hook up the fluid suction piping to the bottom bushing on the pump head. This is a 1/4" (8mm) female pipe connection. Care should be exercised in that a suitable strainer should be installed in the suction line to trap foreign matter that might injure the plunger, plunger packing or interfere with the check valve operation.

10. On hooking up the fluid discharge line, the top connection on the pump head is the outlet and it is a 1/4" (8mm) FNPT. The discharge line should be at least 5/16" (7.9mm) tubing and a TA-676 line check should be installed at the point of injection in case the fluid discharge line ruptures or is broken. Careful observation of the flow direction during installation will eliminate the possibility of a ruptured fluid discharge line.

11. Turn the gas on and slowly open the gas exhaust valve. The pump will start automatically. Make certain the suction line is filled with fluid by opening the priming valve to check for fluid. After the pump discharges clear fluid without bubbles, close the priming valve for normal pumping operations. At this point make a visual check of the plunger drip and using the TA-315 gland wrench, slowly tighten the gland nut until leakage just stops. It may be necessary to readjust the packing the next day. A slight leak during break-in is beneficial. Sufficient time should be allowed to let the packing "seat in". Packing should only be adjusted after pressure has been removed from the pump head. Never adjust packing against pressure.

12. After the pump is in operation, replace the cover and thumb screws.

Start Up and Operation

After the pump has been installed, only a few minor adjustments are necessary for every day operation. Here are a few check points.

1. Check gas supply pressure.

2. Check speed control with the chart which will give you the volume the pump is injecting.

3. Check for excess leakage around the packing gland. If is not possible to stop excess leaking, replace the packing. If the plunger is badly scored, replace the plunger. Do not adjust packing against pressure.

4. Open the priming valve to check pump action.

Maintenance

Lubricate the thrust rod with only Mobilith™ SCH 007 grease per recommended maintenance schedule.

Should the pump run but fail to pump chemical, remove TB-736 bottom bushing and TA-1496 top bushing - inspect and clean balls and seats. Inspect for damage and replace if necessary. Should pump still not pump chemical, remove TB-548 cover and check to see if TA-290 cotter Pin and TA-1828 stroke adjusting pin are in place.

Check to see if chemical is getting to pump, unscrew TA-1497 priming valve stem. When chemical flows from bleed hole, shut TA-1497 priming valve.

If the pump fails to operate after hooking up gas or air to TA-906 (inlet bushing); make sure the inlet pressure does not exceed 35 psig (2.4 bar) - excessive pressure could tend to lock the pump; make sure the speed control valve (gas exhaust) is open; and make sure the plunger packing is not too tight. Use gland wrench TA-315 to adjust packing gland nut TA-6353, if necessary.

If pump stops and a constant flow of gas comes from TA-1835 air vent, this means that the TC-2128 diaphragm has ruptured.

To Replace Diaphragm

Remove TC-252 diaphragm cover. Remove lock nut and washer on end of TB-444. Do not allow TB-444 thrust rod to turn when removing lock nut and washer. To prevent the rod from turning, remove TB-548 cover and hold the rod in position by inserting punch or drift pin into the "large" hole forward of the TA-6564 Stirrup assembly. Replace burst diaphragm and reassemble.

To Replace Return Spring

Remove TC-252 diaphragm cover - remove lock nut and washer on end of TB-444 thrust rod. It is important that you do not allow TB-444 thrust rod to return when moving lock nut and washer. To prevent the rod from turning remove TB-548 cover and hold the rod in position by inserting punch or drift pin into the "large" hole forward of the TA-6564 stirrup assembly.

Pull TC-2128 diaphragm - TB-438 diaphragm plate - return spring TA-1821 can then be removed. Reassemble in reverse of above.

Replacing Ta-4147 Valve Disc Assembly

If the pump has a heavy continuous leaking of gas - TA-4147 valve disc assembly probably needs replacing.

Disconnect power supply into TA-906 disc retainer. Remove TA-906 disc retainer from TA-441 body - caution: care should be taken not to lose TA-77 valve spring and TA-579 washer located directly under TA-906 disc retainer.

Before removing, note the position of the TA-4056 valve disc, so that the disc is replaced to the same position as it was

removed (see page 8). Lap the TA-4056 disc with a good valve grinding compound before replacing.

When replacing TA-4056 valve disc be sure to also replace the TA-4062 drive pin that was supplied when you ordered the disc assembly.

Removing TB-446 Valve Assembly from Pump Housing

Should it be necessary to remove TB-1631 flipper arm assembly from the pump housing, disconnect TB-1193 SS tubing, the power inlet from TA-906 disc retainer and the gas exhaust line. Remove the four P01-031100-3900 machine screws and four P52-031000-3900 lock washers. The TB-446 valve assembly can then be withdrawn from pump body.

The flipper arm bearing is an integral part of the TB-1631 flipper arm assembly and is press fit into the TB-441 body. A punch must be used to remove the flipper arm from the valve body. To do this the procedure under the heading, "Replacing TA-4147 Valve Disc Assembly." must be performed. When these parts are removed the TB-1631 flipper arm assembly may be punched from the body.

Upon reassembling the lower shaft of the TB-1627 flipper arm must fit into the TA-6563 flipper spring adapter.

To Replace The Flipper Spring

Follow the procedure as outlined under "Removing TB-446 Valve Assembly from Pump Housing."

After removing the valve assembly, remove TB-548 cover. At this point TA-6564 stirrup assembly may be turned upside down on the thrust rod - unscrew TA-1820 flipper spring. To reassemble follow the above procedure in reverse.

Technical Specifications

Approved models of this unit comply with the requirements for 94/9/EC-ATEX directive  II 2G c II T3

Approved Models:

5101	5103	5104	5105
------	------	------	------

Does NOT include models with

1. Ceramic plunger
2. Microswitch

Standards Used:

EN ISO 12100:2010	EN 13463-1:2009	EN 13463-5:2011
-------------------	-----------------	-----------------

Pump Weight (without accessories): 38 lbs (17.2Kg)

TB 0040 Regulator Weight: 3lbs (1.4Kg)

Noise Level @ 35 psig (2.4 bar): less than 70dB(A)

Ambient operation temperature: -4°F to +140°F (-20°C to +60°C)

LP and HP

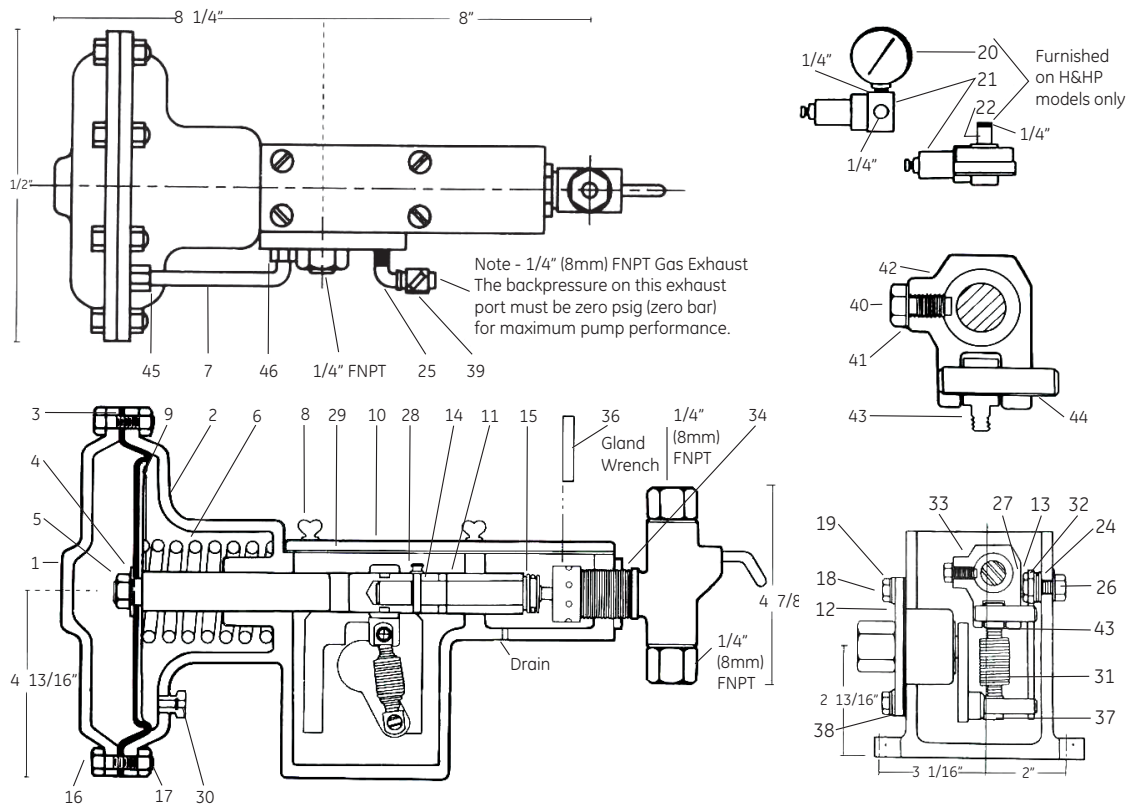

Parts List

Item	Part No.	No. Reqd.	Name	Material
1	TC-0252	1	Diaphragm Cover	Cast Iron
2	TD-0531	1	Housing	Cast Iron
3 ²	TC-2128	1	Molded Diaphragm	Buna-N, Nylon
4	P54-062000-0200	1	Washer	Stl. Zinc Pl.
5	TA-3320	1	Locknut	Stl. Zinc Pl.
6 ²	TA-1821	1	Return Spring	C.S. Zinc Pl.
7	TB-1193	1	Pilot Valve Line Assy.	303 S.S. Tubing
8	P86-025075-0200	4	Wing Screws	Stl. Zinc Pl.
9	TB-0438	1	Diaphragm Plate	Steel
10	TB-0548	1	Cover	Cast Iron
11	TB-0444	1	Thrust Rod	Steel
12	TB-0446	1	Pilot Valve	See Page 7
13	TA-1823	1	Bumper Plate	Steel
14	TB-0447	1	Rod Adapter	Steel
15	TA-0290	1	Pin	Steel
16	P01-037125-3900	8	Hex Hd. Cap Screw	SS
17	P25-037000-3900	8	Hex Nut	SS
18	P01-031100-3900	4	Hex Hd. Mach. Screw	SS
19	P52-031000-3900	4	Lockwasher	SS
20 ¹	TA-1854	1	Pressure Gauge Range 0-35 psig (0-2.4 bar)	Brass Element
21 ¹	TA-1718	1	Regulator	Aluminum/Brass
221	TA-3324	1	Nipple	Stl. Zinc Pl.

Item	Part No.	No. Reqd.	Name	Material
24	P52-037000-3900	1	Light Lockwasher	SS
25	TA-0075	1	Street El.	C.S. Galv.
26	P26-037000-0200	1	Hex. Nut	Semifinish Stl. Zinc Pl.
27	TA-1827	1	Bumper Plate Screw	Steel
28 ¹	TA-1828	1	Adjusting Pin	Steel
29 ¹	TA-1546	1	Gasket	Buna-N
30	TA-1835	1	Air Vent	Brass
31 ²	TA-1820	1	Flipper Spring	Steel
32 ²	P55-037000-0200	3	Washer	C.S. Zinc Pl.
33	TA-6564	1	Stirrup Assembly	Cast Iron & Steel
34		1	Injector Head	Head Assemblies (See page 8 for part list)
36 ²	TA-0315	1	Gland Wrench	Steel
37 ²	TA-6563	1	Spring Adapter (Bottom)	Steel
38 ²	TA-0058	1	Gasket-Pilot Valve	Fiber
39	TA-2489	1	Gas Exhaust Valve	Ni. Plated Brass
40	TA-1829	1	Hex. Hd. Screw	Steel
41	P51-037000-0200	1	Internal Tooth Lockwasher	Carbon Stl. Zinc Pl.
42	TB-0471	1	Trip Stirrup	Cast Iron
43 ²	TA-6563	1	Spring Adapter (Top)	Steel
44 ²	TA-2355	1	Rollpin	Steel
45	TA-4015	1	Male Con. & Comp. Nut	C.S. Zinc Pl.
46	TA-4016	1	Elbow Con. & Comp. Nut	C.S. Zinc Pl.

Notes: ¹Furnished on H & HP models only

² Recommended spare part

³Parts not mounted - packaged with unit

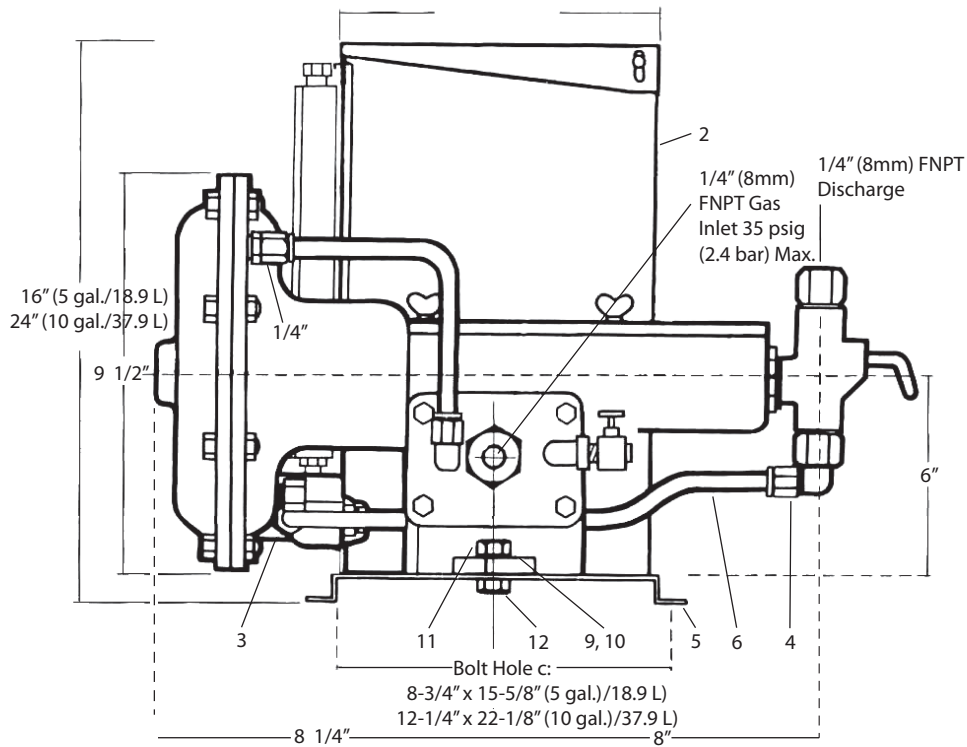

Parts List

Item	Part No.	No. Reqd.	Name	Material
2	TA-0664	1	5 gal./18.9L Tank	430 Stainless Steel
2	TA-1539	1	10 gal./37.9L Tank	304 Stainless Steel
3	TA-3118	1	Connector	Polypropylene
4	TA-3116	1	Elbow Connector &	Polypropylene
		1	Compression Nut Assy.	
5	TA-0950	1	Base, 5 gal./18.9L	Steel
	TB-0758	1	Base, 10 gal./37.9L	Steel
6	TA-3123	1	Suction Line	5/16"x22" Polypropylene
7	TA-2459	1	Screen	Stainless Steel
8	TA-0792	1	Bushing	Brass
9	P53-031000-0200	4	Cut Washer	C.S. Zinc Pl.
10	P52-031000-3900	2	Lockwasher	SS
11	P25-037000-3900	2	Hex Nut	SS
12	P01-031100-3900	2	Hex Head Cap Screw	SS
13	P10-031125-0200	1	Pan Hd. Slotted Machine Screw	Steel Zinc Pl.
14	TB-0871	1	Tank Gauge, 5 gal./18.9L	Assembly
	TB-1285	1	Tank Gauge, 10 gal./37.9L	Assembly

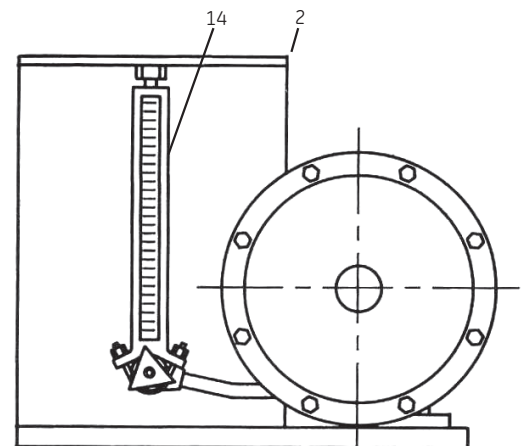
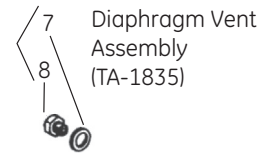

- 1 Recommended spare part
- 2 Between pump and reservoir (same relative position as Item 11)

Pilot Valve Assembly

Parts List

Item	Part No.	No. Reqd.	Name	Material
1	TB-0441	1	Body	Cast Iron
2	TA-4147 TA-4062	1	Valve Disc and Drive- Pin Assy. Pin Only	17-4 Ph SS Steel Hardened
4 ²	TA-0077	1	Valve Spring	Stainless Steel
5	TA-4016	1	Elbow Connector & Compression Nut Assy.	C.S. Zinc Plated
6	P03-025037-0200	1	Hex Socket Cap Screw	Steel
7	P53-025000-0200	1	Washer	C.S.
8	TA-0906	1	Disc Retainer	C.S. Zinc Plated
9	TB-1766	1	Flipper Arm & Bearing Assy.	17-4 SS Flipper Arm with C.S. Bearing
10 ²	TA-0579	1	Washer	Stainless Steel
11	TA-0677	1	Outlet Body	Brass
12 ²	TA-0391	1	Spring	Stainless Steel
13 ²	TA-0054	1	Ball	Stainless Steel
14 ²	TA-2580	1	O-Ring	Viton
	TA-0479	1	O-Ring	Buna-N
15	TA-0678	1	Inlet Body	Brass
16	TA-1296	1	Outlet Body	Stainless Steel
17	TA-1297	1	Inlet Body	Stainless Steel
18 ²	TA-1574	1	Gasket	Stainless Steel
19	TA-2489	1	Valve	Brass, Ni Plated

2 Recommended Spare Part

Parts Required for Sour Gas Applications Furnished Only When Ordering Pump Models H and AP for Sour Gas Applications

Page No.	Item	Part No.	No. Reqd.	Name	Material
5	20	TA-2847	1	Pressure Gauge 0-60 psig (0-4.1 bar)	S.S. Element
5	21	TA-2845	1	Regulator 250 psig (17.2 bar) max. inlet	Aluminum

Pin Only (TA-4062)

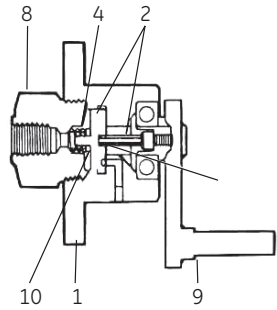

Note: To assemble, move lever arm to left as shown and align hole in pilot valve disc with hole in pilot valve body.

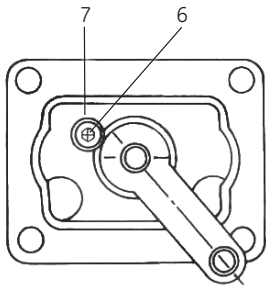

Backside View

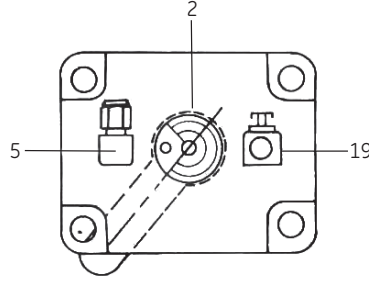

Outside View

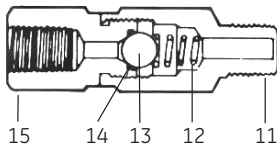

Brass Line Check (TA-676)

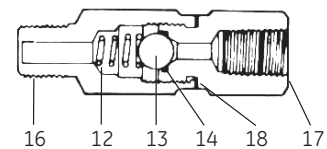

303 SS Line Check (TA-675)

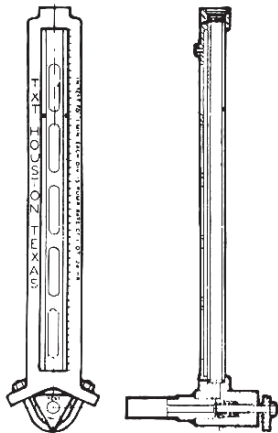

TB-871 Tank Gauge For 5 Gal./18.9 L Tank

Injector Heads

Parts List

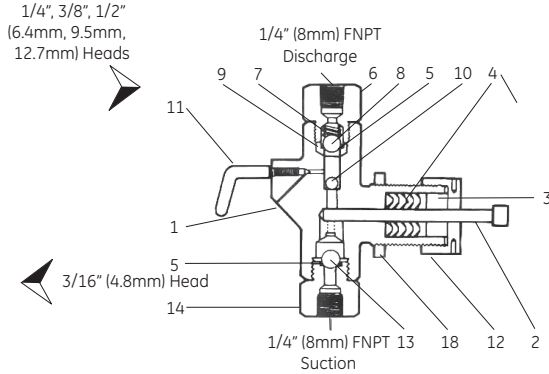
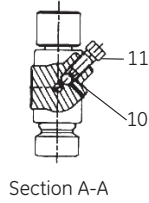
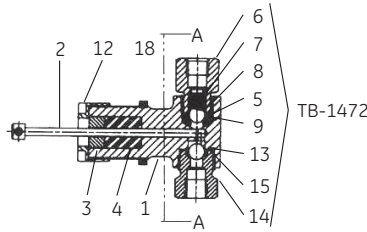

Plunger Size/Model #			3/16" (4.8mm) 5104	1/4" (6.4mm) 5101	3/8" (9.5mm) 5103	1/2" (12.7mm) 5105			
Item No.	Material Specification	Material Construction	All Stainless Steel**	Ductile w/ SS Trim	All Stainless Steel**	Ductile w/ SS Trim	All Stainless Steel**	Ductile w/ SS Trim	All Stainless Steel**
	Head Assembly No.		TB-1472	TB-0166	TB-0755	TB-0203	TB-0756	TB-0496	TB-0732
1	Body		TC-2040	TC-0275	TC-0291	TC-0276	TC-0425	TC-0272	TB-0349
2*	Plunger	17-4 PH	TA-5643	TA-1312	TA-1312	TA-1745	TA-1745	TA-1876	TA-1876
3	Plunger Packing Gland	303-SST	TA-5642	TA-1463	TA-1463	TA-0957	TA-0957	TA-1219	TA-1219
4*	Plunger Packing (see table below for maximum discharge pressures)	Buna-N	TA-3969	TA-1461	TA-1461	TA-1456	TA-1456	TA-0959	TA-0959
		Buna-N Hard	TA-3948	TA-2295	TA-2295	TA-1875	TA-1875	TA-1874	TA-1874
		Viton	TA-3967	TA-4102	TA-4102	TA-4101	TA-4101	TA-4103	TA-4103
		Viton Hard	TA-6253	TA-6555	TA-6555	TA-6556	TA-6556	TA-6557	TA-6557
		Teflon	TA-3966	TA-1642	TA-1642	TA-1234	TA-1234	TA-1012	TA-1012
5*	O-Ring, Suction & Discharge (included in items 8 & 14)	Fluorosilicone	TA-6574	TA-6257	TA-6257	TA-6258	TA-6258	TA-6259	TA-6259
		Buna-N	TA-0479	TA-0479	TA-0479	TA-0479	TA-0479	TA-0479	TA-0479
		Viton	TA-2580	TA-2580	TA-2580	TA-2580	TA-2580	TA-2580	TA-2580
		Teflon	TA-6159	TA-6159	TA-6159	TA-6159	TA-6159	TA-6159	TA-6159
		Fluorosilicone	TA-4113	TA-4113	TA-4113	TA-4113	TA-4113	TA-4113	TA-4113
6	Top Bushing	Kalrez	TA-5037	TA-5037	TA-5037	TA-5037	TA-5037	TA-5037	TA-5037
		Aflas	TA-5073	TA-5073	TA-5073	TA-5073	TA-5073	TA-5073	TA-5073
7*	Ball Check Spring	302-SST	TA-1496	TA-1496	TA-1496	TA-1496	TA-1496	TA-1496	TA-1496
8*	Large Top Ball 3/8" (9.5mm)	316-SST	TA-0077	TA-0077	TA-0077	TA-0077	TA-0077	TA-0077	TA-0077
		316-SST	TA-0054	TA-0054	TA-0054	TA-0054	TA-0054	TA-0054	TA-0054
9*	Top Seat-Assembly Buna-N "O" Ring	Hastelloy	TA-0064	TA-0064	TA-0064	TA-0064	TA-0064	TA-0064	TA-0064
	Top Seat-Assembly (Metal-to-Metal)	303-SST	TB-0737	TB-0737	TB-0737	TB-0737	TB-0737	TB-0737	TB-0737
10*	Small Top Ball 1/4" (6.4mm)	303-SST	N/A	TA-0806	TA-0806	TA-0806	TA-0806	TA-0806	TA-0806
		316-SST	N/A	TA-0126	TA-0126	TA-0126	TA-0126	TA-0126	TA-0126
11	Priming Valve	303-SST	TA-5462	TA-1497	TA-1497	TA-1497	TA-1497	TA-1497	TA-1497
12	Nut, Plunger Packing Gland	303-SST	TA-6353	TA-6353	TA-6353	TA-6353	TA-6353	TA-6353	TA-6353
	Suction Ball 3/8" (9.5mm)	303-SST	TA-5462	TA-1497	TA-1497	TA-1497	TA-1497	TA-1497	TA-1497
13	Suction Ball 1/2" (12.7mm) (Use with TA-0771) Metal-to-Metal Bottom Seat only	316-SST	TA-0054	TA-0054	TA-0054	TA-0054	TA-0054	TA-0054	TA-0054
		Hastelloy	TA-0064	TA-0064	TA-0064	TA-0064	TA-0064	TA-0064	TA-0064
14*	Bottom Seat Bushing Metal-to-Metal (Use w/TA-0053 1/2" (12.7mm) Ball Only)	316-SST	N/A	TB-0053	TB-0053	TB-0053	TB-0053	TB-0053	TB-0053
		Bottom Seat (w/Buna-N "O-Ring)	303-SST	TB-1216	TB-0736	TB-0736	TB-0736	TB-0736	TB-0736
15	Gasket	303-SST	N/A	TA-0771	TA-0771	TA-0771	TA-0771	TA-0771	TA-0771
18	Locknut	304-SST	TA-4394	N/A	N/A	N/A	N/A	N/A	N/A
		Brass	TA-0225	TA-0225	TA-0225	TA-0225	TA-0225	TA-0225	TA-0225

¹Recommended spare parts ²Ductile not available

Plunger Packing - Max Discharge Pressure (Metric)

Material	Pressure (BAR)			
	4.8mm	6.4mm	9.5mm	12.7mm
Buna-N	206.8	206.8	206.8	206.8
Buna Hard	413.7	413.7	413.7	241.3
Viton Hard™	413.7	413.7	413.7	241.3
Viton™	206.8	206.8	206.8	206.8
Teflon™	206.8	206.8	206.8	206.8

Plunger Packing - Max Discharge Pressure (U.S. Customary)

Material	Pressure (PSIG)			
	3/16"	1/4"	3/8"	1/2"
Buna-N	3000	3000	3000	3000
Buna Hard	6000	6000	6000	3500
Viton Hard™	6000	6000	6000	3500
Viton™	3000	3000	3000	3000
Teflon™	3000	3000	3000	3000

5100 Microswitch Valve Installation

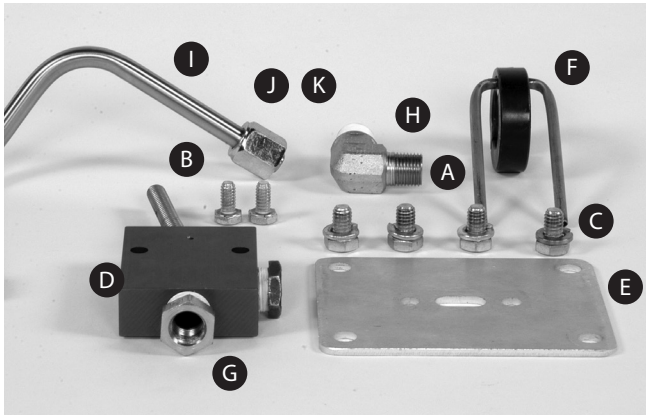

TA 7093 Microswitch Valve Kit

Item	Part No.	Name	Material
A.	P01-031050-0200	HHCS	C.S. Zinc Pl.
B.	P01-025050-0200	HHCS	C.S. Zinc Pl.
C.	P52-031000-0200	Lockwasher	C.S. Zinc Pl.
D.	TA 7222	Microswitch	Aluminum
E.	TA 7088	Microswitch Mounting Plate	Aluminum
F.	TA 7090-1	Thrust Collar Assembly	
G.	TA 7095	Bushing	C.S. Zinc Pl.
H.	TA 4016	Elbow	C.S. Zinc Pl.
I.	TA 7092	Tubing	S.S.
J.	TA 7097	Ferrule	C.S. Zinc Pl.
K.	TA 7098	Flareless Nut	C.S. Zinc Pl.

Installation Steps 1 through 3

1. If pump is installed in the field, shut off gas flow to the pump.
2. Disconnect the gas supply pipe from the TA-0906 disc retainer gas inlet to the pump. Disconnect and remove the TB-1193 pilot valve line assembly as shown below.
3. Remove the four P01-031-3900 machine screws and four P52-031000-3900 lock washers and remove the switching valve assembly, TB 0446, from the pump housing.

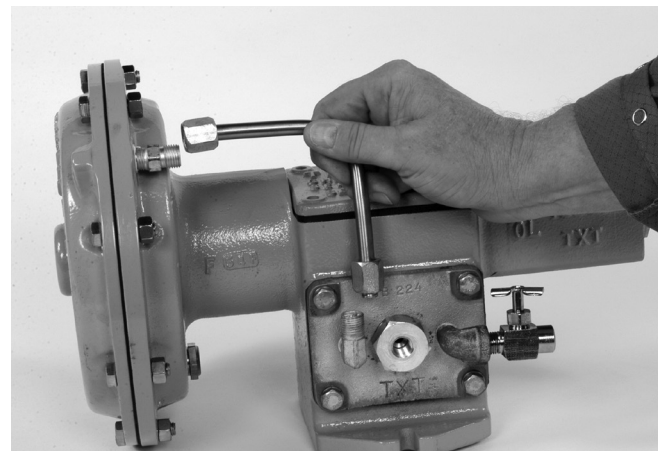

TB 1193 Removal

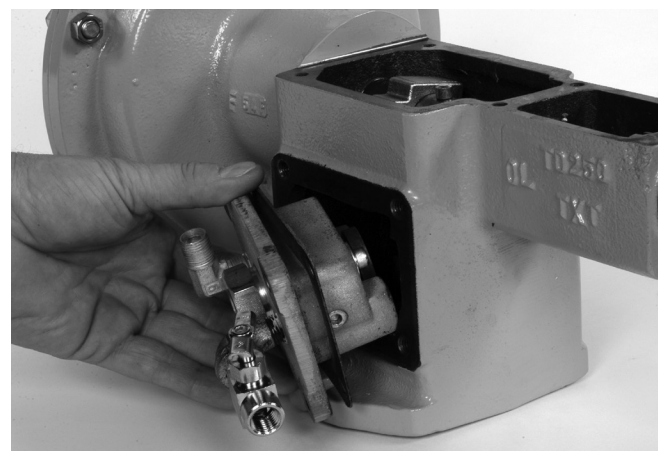

Switching Valve Assembly Removal

Installation

Steps 4 through 9

4. Remove the TB-0548 cover.
 5. Remove adjusting pin, TA-1828.
 6. Remove TC-0252 diaphragm cover.
 7. Pull diaphragm TC-2128 and thrust rod TB-0444 out.
 8. Remove stirrup assembly TA-6564.
-
9. Remove Bumper Plate Assembly, TA-1823, TA-0459, TA-3323, and TA-1827.

Steps 10 through 12

10. Install microswitch thrust rod collar assembly TA-7090-1. Ensure that the clamping bolt is on the opposite side of the thrust rod from where the microswitch will be installed. Place TA 7090-1 over the area where the stirrup assembly TA 6564 would normally attach to the thrust rod. Do not tighten the clamping bolt at this time.
11. Push the diaphragm TC-2128 back into position and reinstall the TC-0252 diaphragm cover.
12. Reinsert TA-1828 adjusting pin.

Steps 13 through 14

13. Install TA-2222 microswitch valve onto the TA-7088 mounting plate with the two P01-025050-0200 HHCS. Ensure the "TXT" tag is facing up.
14. With the microswitch installed in the mounting plate, ensure the lever arm is switched to the left position. Place the gasket, TA-0058 between the mounting plate and the housing, then attach the mounting plate to the pump housing, TD-0531 using the four HHCS, P01-031050-0200, with the four lock washers, P52-031000-0200. Ensure the microswitch valve extended shaft is between the forks on the TA-7090-1 assembly.

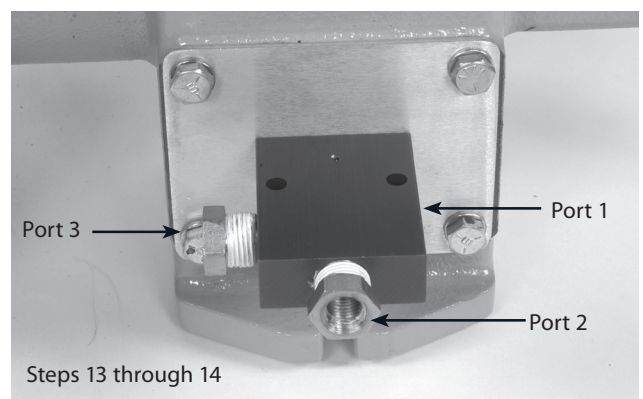
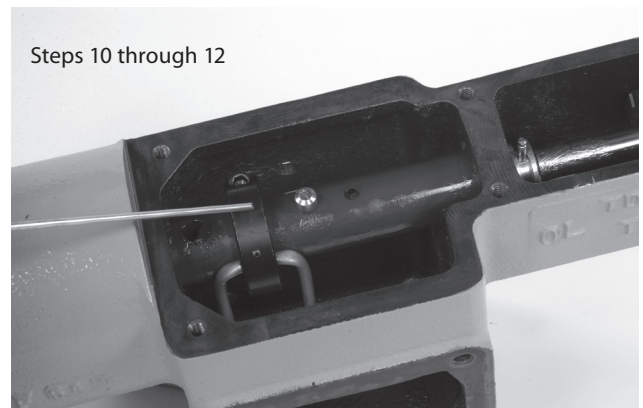
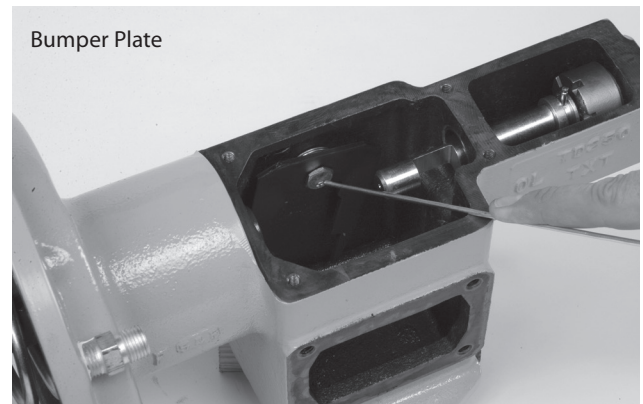
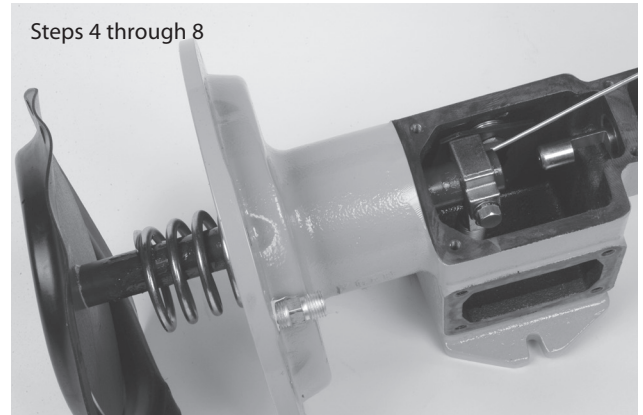

Microswitch Assembly Installed

Installation

Speed Control Valve Installation

15. Attach the speed control valve, TA-2489 to the exhaust, Port 3 (left port).

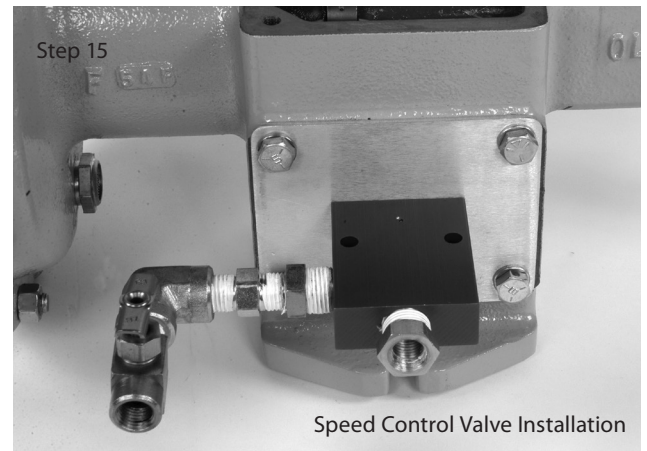

Steps 16 through 19

16. Attach the 1/4" (8mm) MNPT X 3/8" (9.5mm) tubing 90° elbow, TA-7096, to Port 2 (center port).

17. Assemble the tubing using the ferrule, TA-7097, and flareless nut, TA-7098, then attach the tubing assembly, TA-7092, to the elbow and to the pump head.

18. Tighten the clamping bolt on the thrust rod collar assembly.

19. Connect supply gas to Port 1 on the microswitch valve. Stroke the pump several times. You may need to adjust the location of the thrust rod collar to optimize operation of the pump.

20. Control the speed of the pump using the gas supply pressure and the speed control valve to achieve the desired stroke rate.

Min. gas pressure: 18 psig (1.2 bar)

Max. gas pressure: 35 psig (2.4 bar)

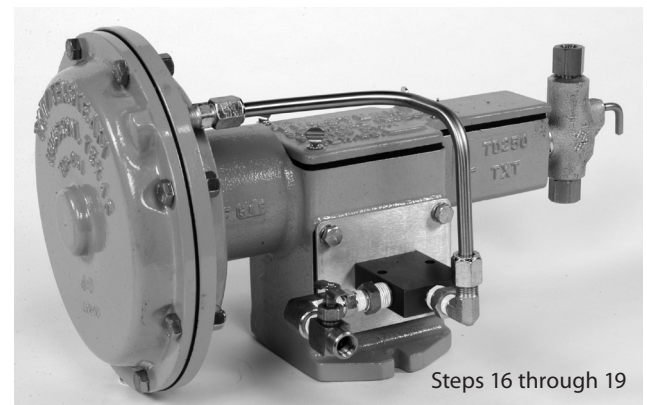

Microswitch Valve Replacement

1. Shutoff gas flow to the pump.
2. Disconnect the gas supply pipe from Port 1 on the microswitch valve.
3. Disconnect and remove TA-7092 tubing assembly.
4. Remove two bushings, TA-7095, from Ports 2 and 3 on the microswitch valve.
5. Remove the TB-0548 cover.
6. Remove the four P01-031-3900 machine screws and four P52-031000-3900 lock washers. Remove the microswitch valve assembly from the pump housing.
7. Remove the old microswitch from the mounting plate and replace with the new microswitch.
8. Reinstall the mounting plate with microswitch valve and gasket using the four machine screws and lock washers. Ensure the microswitch valve extended shaft is between the forks of the TA-7090-1 assembly.
9. Reinstall the TB-0548 cover.
10. Replace the TA-7095 bushings back into ports 2 and 3 as shown.
11. Reconnect the TA-7092 tubing assembly.
12. Reconnect the gas supply line to the microswitch valve.

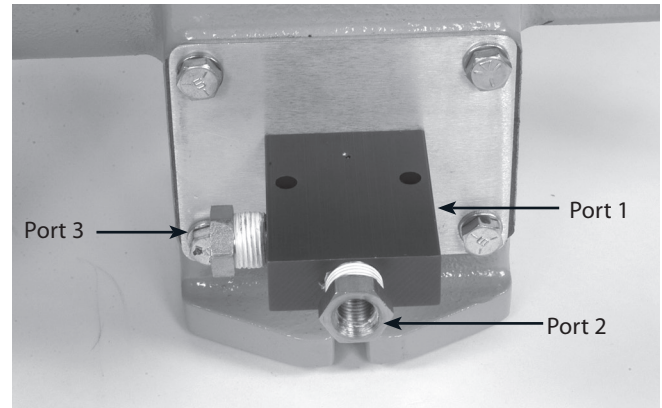

Troubleshooting

⚠ WARNING—Shut off and relieve the gas supply pressure before handling pump.

1. Check that the pump supply pressure is 0-35 psig (0-2.4 bar).
2. The plunger should be pinned to the thrust rod.
3. Check for obstructions in the pump body, and remove if necessary.
4. Verify that the thrust rod is lubricated where it is in contact with the bushings.
5. Inspect the pilot valve and check that it is functioning properly. If it is not, have qualified personnel repair it.
6. Inspect the diaphragm for damage and have qualified personnel repair it if it is damaged.
7. Ensure exhaust valve is open (if pump will not run).
8. Fluid discharge pressure cannot exceed the rated fluid discharge pressure per pump model for proper and safe performance.

Misc.

It is advised to lift the 5100 pump with a suitable fiber-enforced rope and lifting device such as a crane to avoid injury. Strap placement can be seen in the figure (right). For long-range transport, either box pumps and surround with a soft packing medium suitable for shipping, or palletize and wrap the pumps to protect from the elements.

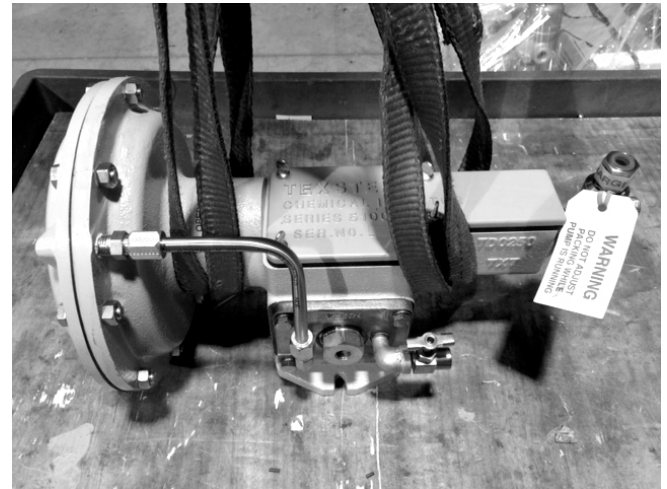

DIRECT SALES OFFICE LOCATIONS

AUSTRALIA

Brisbane:
Phone: +61-7-3001-4319
Fax: +61-7-3001-4399
Perth:
Phone: +61-8-6595-7018
Fax: +61 8 6595-7299
Melbourne:
Phone: +61-3-8807-6002
Fax: +61-3-8807-6577

BELGIUM

Phone: +32-2-344-0970
Fax: +32-2-344-1123

BRAZIL

Phone: +55-19-2104-6900

CHINA

Phone: +86-10-5689-3600
Fax: +86-10-5689-3800

FRANCE

Courbevoie
Phone: +33-1-4904-9000
Fax: +33-1-4904-9010

GERMANY

Ratingen
Phone: +49-2102-108-0
Fax: +49-2102-108-111

INDIA

Mumbai
Phone: +91-22-8354790
Fax: +91-22-8354791
New Delhi
Phone: +91-11-2-6164175
Fax: +91-11-5-1659635

ITALY

Phone: +39-081-7892-111
Fax: +39-081-7892-208

JAPAN

Tokyo
Phone: +81-03-6871-9008
Fax: +81-03-6890-4620

KOREA

Phone: +82-2-2274-0748
Fax: +82-2-2274-0794

MALAYSIA

Phone: +60-3-2161-0322
Fax: +60-3-2163-6312

MEXICO

Phone: +52-55-3640-5060

THE NETHERLANDS

Phone: +31-15-3808666
Fax: +31-18-1641438

RUSSIA

Veliky Novgorod
Phone: +7-8162-55-7898
Fax: +7-8162-55-7921
Moscow
Phone: +7 495-585-1276
Fax: +7 495-585-1279

SAUDI ARABIA

Phone: +966-3-341-0278
Fax: +966-3-341-7624

SINGAPORE

Phone: +65-6861-6100
Fax: +65-6861-7172

SOUTH AFRICA

Phone: +27-11-452-1550
Fax: +27-11-452-6542

SOUTH & CENTRAL AMERICA AND THE CARIBBEAN

Phone: +55-12-2134-1201
Fax: +55-12-2134-1238

SPAIN

Phone: +34-93-652-6430
Fax: +34-93-652-6444

UNITED ARAB EMIRATES

Phone: +971-4-8991-777
Fax: +971-4-8991-778

UNITED KINGDOM

Bracknell
Phone: +44-1344-460-500
Fax: +44-1344-460-537

Skelmersdale

Phone: +44-1695-526-00
Fax: +44-1695-526-01

UNITED STATES

Jacksonville, Florida
Phone: +1-904-570-3409

Corpus Christi, Texas

Phone: +1-361-881-8182
Fax: +1-361-881-8246

Deer Park, Texas

Phone: +1-281-884-1000
Fax: +1-281-884-1010

Houston, Texas

Phone: +1-281-671-1640
Fax: +1-281-671-1735

Texsteam Pumps

16240 Port Northwest Drive

Houston, TX 77041

T: 832-590-2306

Toll Free: 1-800-945-9898

F: 713-849-2879

© 2021 Natural Gas Solutions North America, LLC – All rights reserved. Dresser Utility Solutions reserves the right to make changes in specifications and features shown herein, or discontinue the product described at any time without notice or obligation. Contact your Dresser Utility Solutions representative for the most current information. The Dresser Logo and all Trademarks containing the term "Dresser" are the property of Dresser, LLC, a subsidiary of Baker Hughes.



www.dresserutility.com

Texsteam 5100 Series IOM NGS.IPG.0015a

08.21