



**TOTAL PIPING SOLUTIONS, INC.**

**TRIPLE-TAP®**

**Type "T3" Wide Range**

**Service Saddle**

**10" Wide - Multi Panel**

**Technical Specifications**

Product Design Covered by US Patent 9970584

# TRIPLE TAP® “T3” Wide Range Service Saddle Specifications

Patent Pending

1. Pressure Rating: Triple Tap® “T3” Service Saddles by Total Piping Solutions, Inc. when properly installed are capable of working pressures up to 175 psi with hydrostatic test pressures up to 275 psi.  
  
Note: Pressure rating will not exceed the pressure rating of the pipe on which the service saddle is installed. For any particular installation, the allowable working pressure will be determined by the size of pipe, type of pipe, condition of the pipe, service conditions, environmental conditions, and installation workmanship. Always consult the factory for specific information regarding application and working pressure.
2. Temperature Rating: Maximum Continuous Working Temperature Range is 180° F for Standard NSF NBR Gasket
3. Sealing Gasket: NSF-61 Approved NBR Rubber – For water service
4. Band: 9.875” Wide, 18 to 36 inch diameters – 14 gage (.075”) thickness – Double Panel
5. Mains Pipe : TPS Triple Tap® “T3” Service Saddles are designed for use with Steel, Cast Iron, Ductile Iron, PVC, High Density Polyethylene (SDR 17 or Thicker), Asbestos Cement conductor pipe materials.

# TRIPLE TAP® “T3” Wide Range Service Saddle Specifications

Patent Pending

## TRIPLE TAP® “T3” Wide Range Service Saddle Benefits

1. No special tools required to install the sleeve.
2. Seals on the outlet aperture. (Not a 360° Band Seal)
3. Outlet sizes include ½” through 2” in both NPT and CC threads.
4. Outlet design features a spin-extruded branch with higher strength welds.
5. Equipped with an isolation boot that prevents metal band contact with the pipe and reduces the potential for corrosion when used on ferrous pipe materials.
6. Unique Patented extended Cam Lug system provides a maximum of 0.9 in of diameter range for single panel saddles and up to 1.9” of diameter range for double panel saddles.
8. Patented Cam Lug system includes built in handle for ease of installation.
9. Note: See Materials of Construction diagram for additional information.

## Triple Tap® “T3” Wide Range Service Saddles Multi-Panel

Nominal Diameter	Lower Diameter	Upper Diameter	Connection Sizes	CTS	IPS	DI	Pit Cast	AC100	AC150	AC200
18	19.32	21.04	1/2 to 2"		20.00	19.50	19.92	19.90	20.94	
18 o.s.	21.10	22.80	1/2 to 2"			21.60	22.06		21.30	22.54
20	23.20	25.10	1/2 to 2"		24.00			23.64		25.02
24	25.60	27.30	1/2 to 2"			25.80	26.32	27.17		
24 o.s.	27.80	29.70	1/2 to 2"					28.32	29.62	
30	29.70	30.30	1/2 to 2"		30.00					29.98
30 o.s.	31.96	32.46	1/2 to 2"			32.00	32.40			
36	35.80	36.20	1/2 to 2"		36.00					
36 o.s.	38.10	38.50	1/2 to 2"			38.30				
42	44.3	44.7	1/2 to 2"			44.50				
48	50.6	51.00	1/2 to 2"			50.80				

# TRIPLE TAP® “T3” Wide Range Service Saddle Specifications

Patent Pending

## Applicable Standards:

**ASTM A380-06** Standard Practice for Cleaning Descaling and Passivation of Stainless Steel Parts Equipment and Systems

**ASTM A967-05** Standard Specification for Chemical Passivation Treatments for Stainless Steel Parts.

**ANSI/AWWA C800** Standard for Underground Service Line Valve and Fittings

**NSF/ANSI STANDARD 61** - Drinking Water System Components

**ASTM D2000 - 12** Standard Classification System for Rubber Products.

## Product Warnings

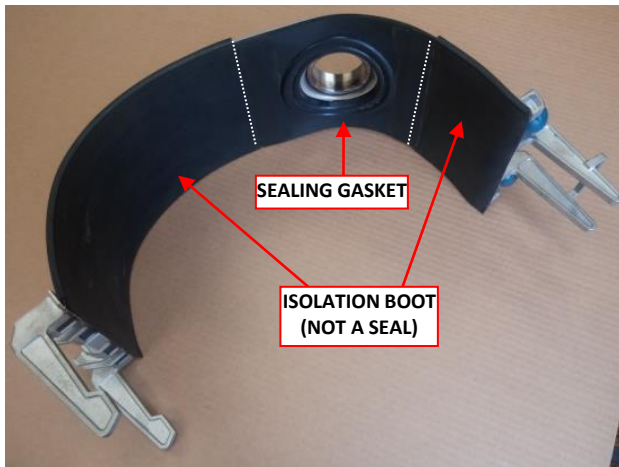

**\*\* Note: Provides aperture seal only, Not a 360° sealing Product\*\***

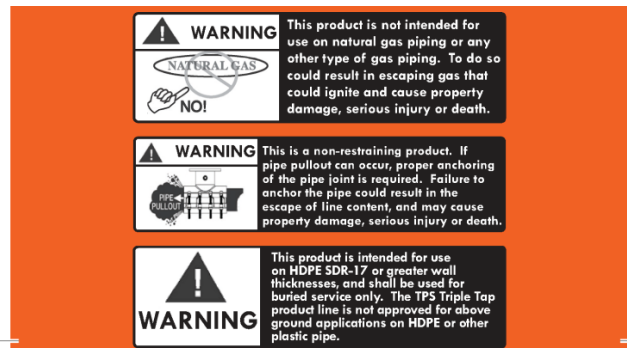

## Saddle Reuse:

**Saddles must not be reused until refurbished at TPS**

# TRIPLE TAP® "T3" Wide Range Service Saddle Specifications

Patent Pending

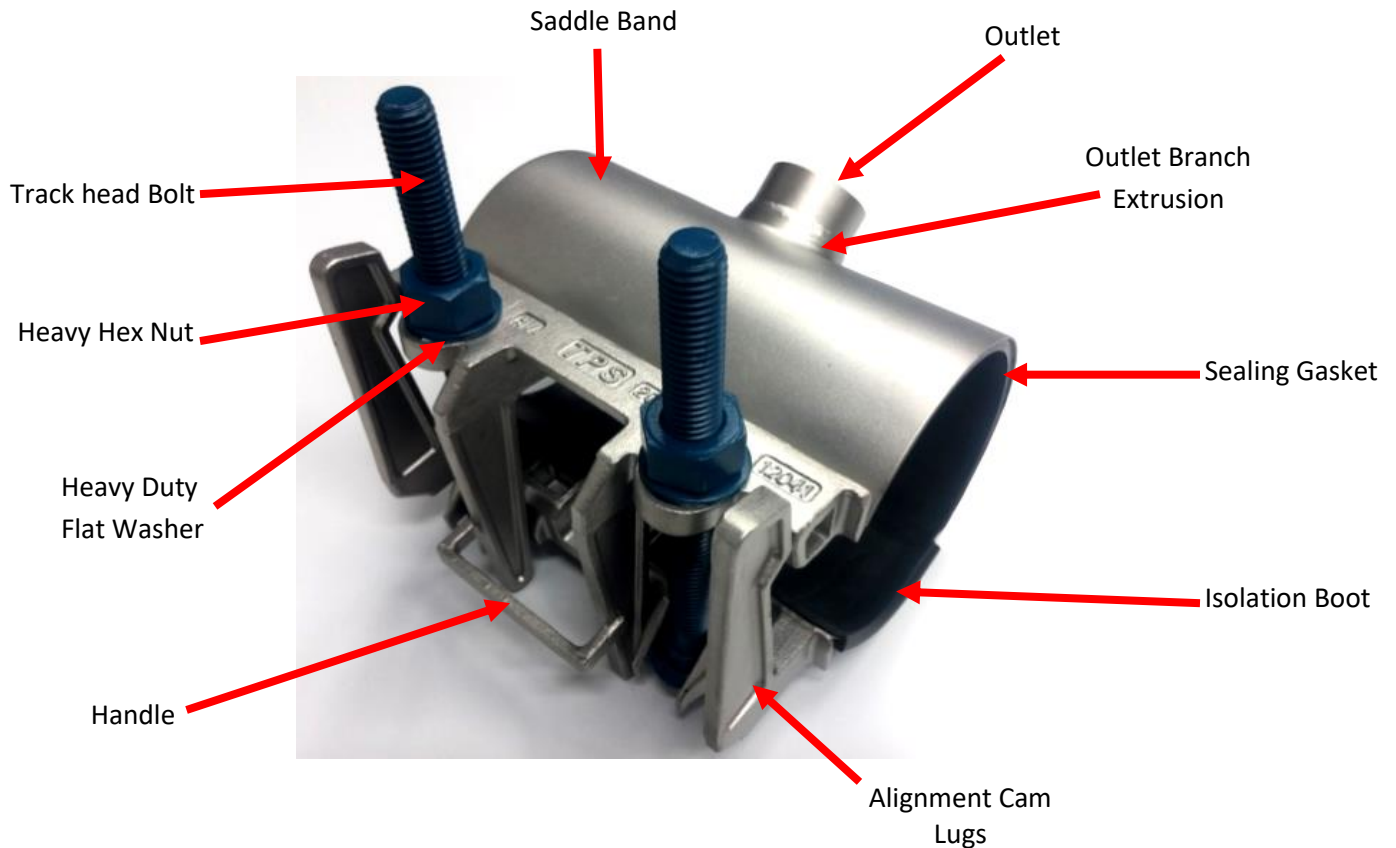

## Materials of Construction

<b>Outlet:</b>	18-8 Stainless Steel
<b>Saddle Band:</b>	14 Gage 18-8 Stainless Steel
<b>Alignment Cam Lugs:</b>	Removable 18-8 Stainless Steel
<b>Gaskets:</b>	Material: Nitrile Butadiene Rubber(NBR)Approved NSF-61
<b>Isolation Boot:</b>	Ethylene Propylene Diene Monomer (EPDM) Rubber
<b>Bolts:</b>	Oval Neck Track head per ANSI/ASME B18.10 5/8-11 UNC Rolled Thread 18-8 Type 304 Stainless Steel per ASTM A-193 Grade B8 Finish: Double Fluoroelastomer coating.
<b>Nuts:</b>	Heavy Hex Nut 5/8-11 UNC Rolled Thread Type 316 High Temp Stainless Steel per ASTM A-194 Grade 8 Finish: Double Fluoroelastomer coated to prevent galling.
<b>Washers:</b>	Heavy Duty 5/8 Inch Washer Material 18-8 Type 304 Stainless Steel Double Fluoroelastomer coated to prevent galling

# TRIPLE TAP® "T3" Wide Range Service Saddle Specifications

Patent Pending

## Features

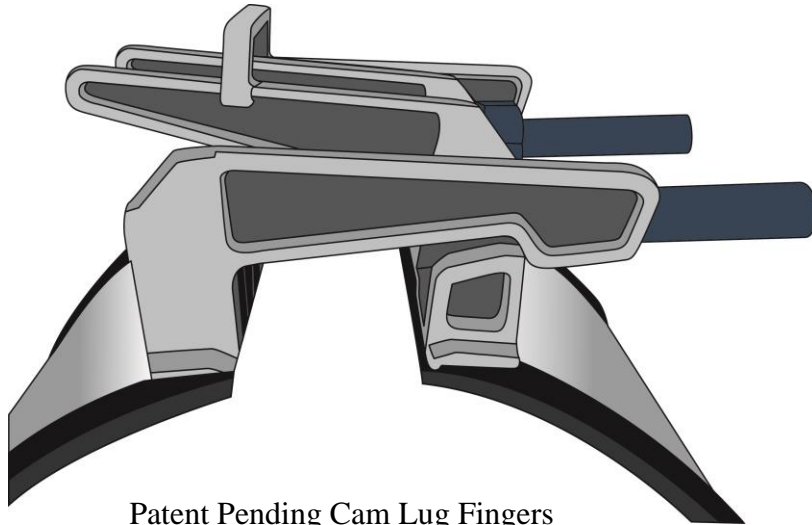

Patent Pending Cam Lug Fingers  
For Extended Range & Ease of  
Installation

Body 100% Isolated  
from Pipe with  
Sealing Gasket and  
Isolation Boot to  
prevent Bi-Metallic  
Corrosion. Also  
allowing saddle to  
grip smooth pipe  
better.

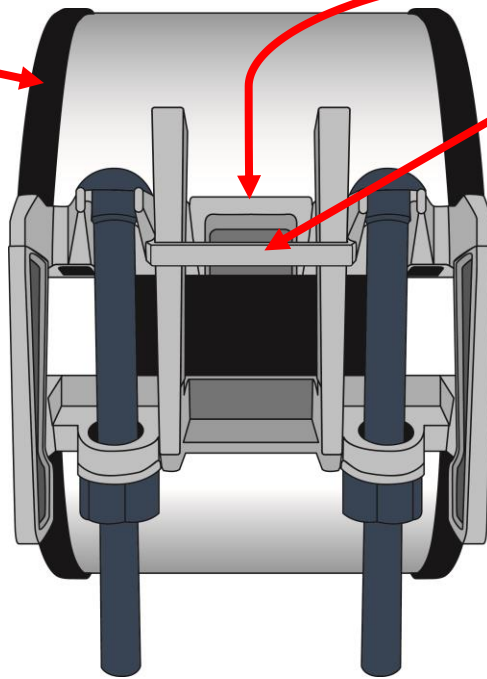

Integrated Handle and Finger  
Tab for Ease of Installation.