

GAS SERVICE VALVES

For Natural Gas Distribution Piping Systems

Maintenance-Free and 100% Tamper-Proof to DOT 192.363. Part C Specs

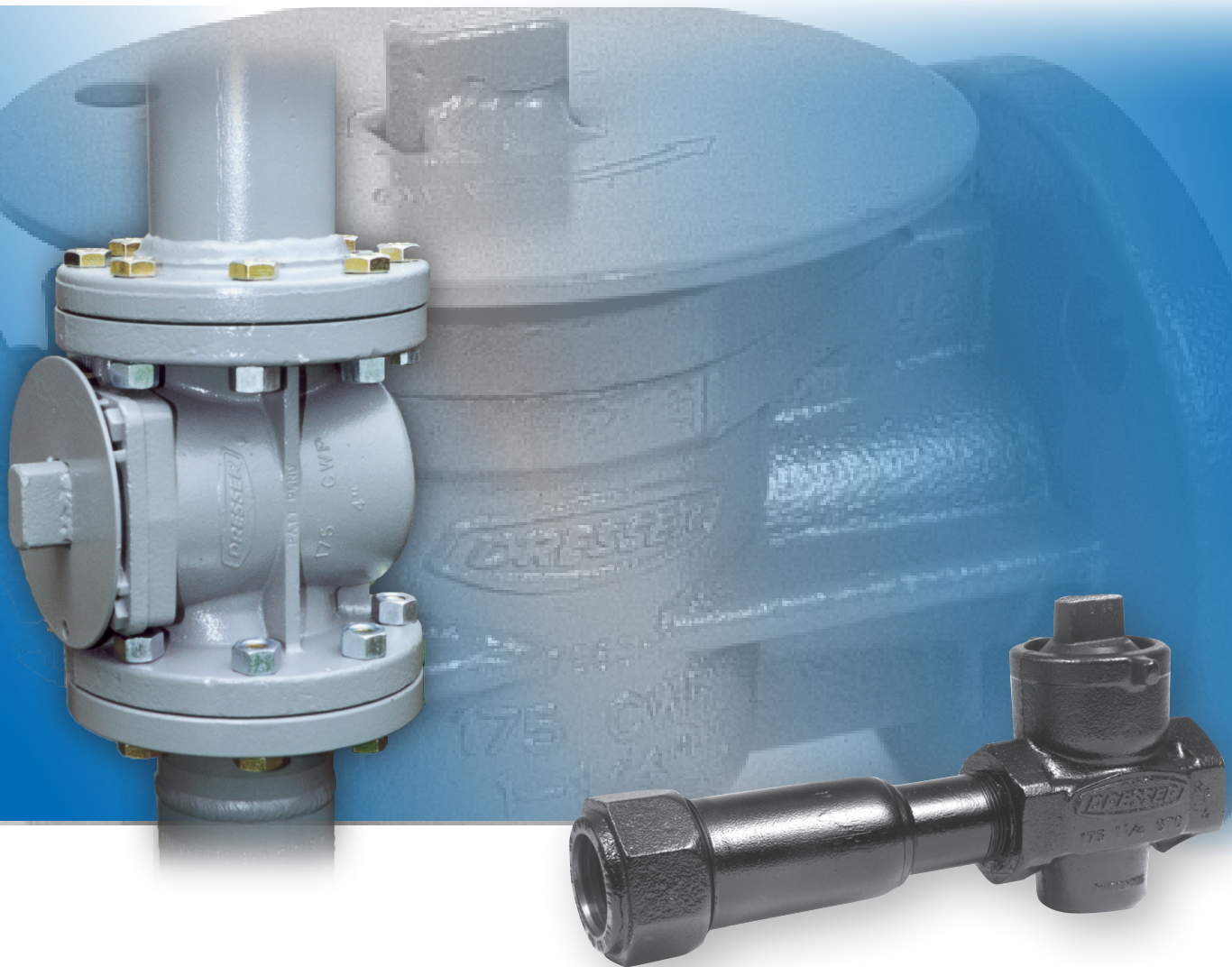

Dresser Style 175 Couplings and Fittings for PE service are
100% compliant to DOT 192.281(e)/ ASTM F1948 Category 1

Style 175 Meter/Curb Valve - Compression x Compression

Incorporates Style 90 Universal Compression Ends for Steel to Steel, Steel to PE, and PE to PE creating seal & restraining connections

- Maintenance-free service with permanent lubrication at the factory
- Low operating torque for no plug “freezing”
- 100% shutoff; Optional 360° turn or 90° open-left operation
- Tamper-proof design
- No leakage to the atmosphere
- Coverage of full pressure range with one valve
- Also available with Style 501 Seal-Plus ends for CTS polyethylene pipe

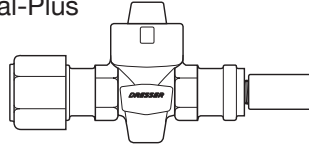

The Dresser Style 175 gas service valve uses two complementary sealing principles that work together for positive shutoff at all rated working pressures to 175 psi. The oil-tempered steel spring exerts a constant force on the tapered plug and seal inserts, providing a seal against low line pressure. At higher pressures, this spring load is supplemented through a unique design that employs line pressure to exert an additional positive sealing force. As line pressure is increased, greater sealing force on the elastomeric seals is produced, causing the valve to remain gas tight at all pressures within its recommended working range.

Tamper-Proof per DOT Specifications

The Style 175 valve is assembled at the factory and sealed against tampering by a spring-loaded stainless steel retaining ring that cannot be removed with ordinary tools. It is tamper proof as specified in DOT 192.363 Part C.

Low Operating Torque

A TFE coated retaining ring, plus permanently lubricated port seals, help ensure low, uniform operating torque, preventing the plug from freezing to the body.

100% Factory Tested

Each valve is tested at high and low pressure while in a clear, non-corrosive fluid.

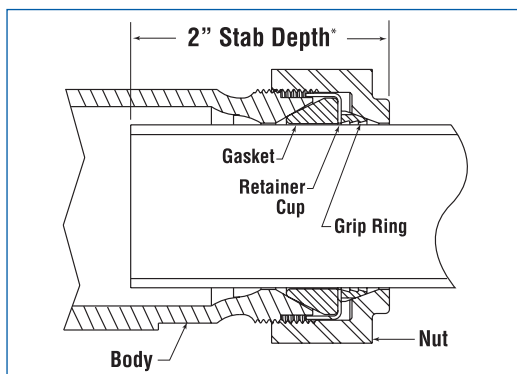
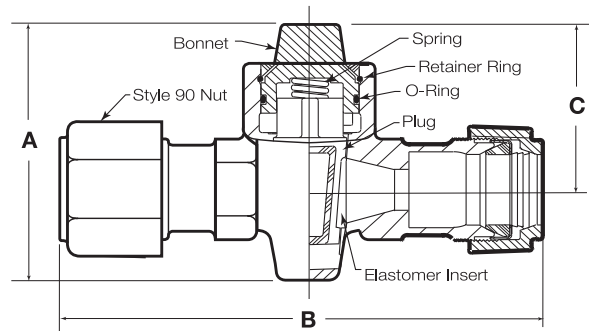

Style 175 valves are offered with the Universal 90 seal-and-restraint design with steel retainer grip rings to create a positive pipe restraint on both pipe ends. Proper Dresser insert stiffeners are included when ordering for PE connections.

Style 175 Meter Valve with Style 90 Compression Ends

Pipe	Nom Size (ID) (in)	Outside Diameter (OD) (in)	SDR	A	B	C
Steel x Steel	1-1/4	1.660	—	6	9-3/4	3-7/8
	1-1/2	1.900	—	6	10-1/2	4-7/32
	2	2.375	—	7	10-3/4	4-1/2
Steel x PE	1-1/4	1.660	10	6	9-3/4	3-7/8
	1-1/4	1.660	11	6	9-3/4	3-7/8
and	1-1/2	1.900	11	6	10-1/2	4-7/32
	1-1/2	1.900	11	6	10-1/2	4-7/32
PE x PE	2	2.375	11	7	10-3/4	4-1/2
	2	2.375	11	7	10-3/4	4-1/2

Material Specifications

Body and Bonnet	Cast Gray Iron - ASTM A126 Class B (Semi-Steel)
Plugs	1-1/4" and 1-1/2" Aluminum Alloy
	2" Plug - Cast Gray Iron, ASTM A126 Class B (Semi-Steel)
Elastomer Seal	Molded, Permanently Lubricated
Elastomer Seal Inserts	Elastomer, Bonded to C-1018 Steel Plate
Retainer Ring	TFE Coated Type 304 Stainless Steel
Bonnet Seal O-Ring	BUNA-S for Gas Service Applications
Spring	Oil-Tempered Steel to ASTM A-229 Specifications
End Gaskets	BUNA-S For Gas Service
Retainer Cup	Stainless Steel
Grip Ring	Nickel Plated Per ASTM B733

Style 175 GTO Threaded Gas Valve FIPS x FIPS

Gas-Tight, Maintenance-Free and Permanently Lubricated





- Maintenance-free service with permanent, factory-installed lubrication
- Low operating torque for no plug “freezing”
- 100% shutoff; Optional 360° turn or 90° open-left operation
- Tamper-proof design
- No leakage to the atmosphere

Designed to meet the requirements of ANSI B16.33 1981, the Dresser Style 175 GTO gas service valve incorporates the same complementary sealing principles as the Style 175 meter curb valve, yet offered with threaded ends for steel to steel connections. Each GTO valve is 100% factory-tested at high and low pressure while in a clear, non-corrosive fluid.

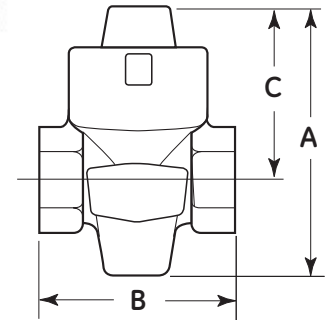
Like the Style 175 meter curb valve, the GTO is assembled at the factory and sealed against tampering by a spring-loaded stainless steel retaining ring that cannot be removed with ordinary tools. It is tamper proof as specified in DOT 192.363 Part C.

A TFE coated retaining ring, plus permanently lubricated port seals, help ensure low, uniform operating torque, preventing the plug from freezing to the body.



- Elastomeric port seals have a compounded-in lifetime lubricant. 
- Spring loading of the plug assures automatic plug adjustment. There are no retaining nuts to tighten or replace. 
- An O-ring provides a gas-tight seal at the top. There is no bottom opening. 
- A permanent bubble-tight seal is achieved by the interaction of two unique design features: spring loading and line pressure. 



Tapping Boss
(for testing purposes)

Style 175 GTO Size Specifications			
Nom Pipe Size	A	B	C
3/4"	4-13/16"	3"	3-1/16"
1"	5-5/16"	3-5/8"	3-17/32"
1-1/4"	5-3/16"	4-9/16"	3-7/8"
1-1/2"	6-7/16"	5-5/32"	4-7/32"
2"	6-15/16"	5-23/32"	4-1/2"

Material Specifications	
Body and Bonnet	Cast Gray Iron - ASTM A126 Class B (Semi-Steel)
Plugs	3/4", 1", 1-1/4" and 1-1/2" Aluminum Alloy
2" Plug	Cast Gray Iron - ASTM A126 Class B (Semi-Steel)
Elastomer Seal	Molded, Permanently Lubricated
Elastomer Seal Inserts	Elastomer, Bonded to C-1018 Steel Plate Inserts
Retainer Ring	TFE Coated Type 304 Stainless Steel
Bonnet Seal O-Ring	BUNA-S for Gas Service Applications
Spring	Oil-Tempered Steel to ASTM A-229 Specifications

Style 175 'Cut-In' Meter/Curb Valve

Available in two configurations - FIPS x Compression and Universal 90 x 90 Compression Ends for any combination of Steel and PE connections

The Dresser Style 175 Cut-In valve permits easy replacement of existing threaded or compression end curb valves as well as installation in service lines without curb valves. Using the same sealing principle as the other 175 valves, the 'Cut-In' 175 provides top performance from inches of water column to 175 PSI.

The 'Cut-In' valve is available for both Steel and PE service connections with Universal 90 Compression x Compression or FIPS x Compression ends, and is thoroughly tested at high and low pressure prior to shipment.

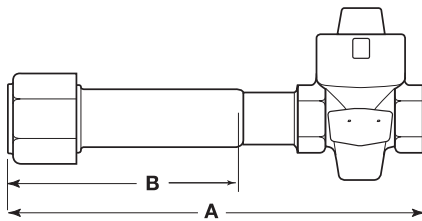

Style 175 'Cut-In' FIPS X 90 Curb Valve

Standard or Universal 90 Compression End
(Style 90 Universal end provides a seal & restraining connection.
SDR included for PE connections)

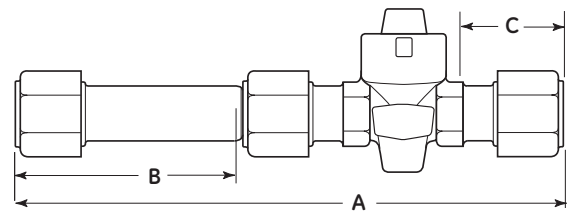

Style 175 'Cut-In' 90 X 90 Curb Valve

Standard or Universal 90 Compression Ends
(Style 90 Universal ends provide a seal & restraining connection.
SDR included for PE to PE connections)

FIPS x Compression End Configuration			
Nom. Size (in)	A Length (in)	B Cut-in Adapter Depth (in)	SDR for PE End (4" Long)
1-1/4	12-3/8	5	10
1-1/2	12-3/4	5	11
2	13-1/4	5	11

Compression x Compression End Configuration				
Nom. Size (in)	A Length (in)	SDR for PE End (4" Long)	B Cut-in Adapter Depth (in)	C Pipe Entrance Depth (in)
1-1/4	14-3/4	10	5	2-3/4
1-1/2	15-1/4	11	5	2-3/4
2	15-3/4	11	5	2-3/4

Material Specifications

Body and Bonnet	Cast Gray Iron - ASTM A126 Class B (Semi-Steel)
Plugs	1-1/4" and 1-1/2" Aluminum Alloy 2" Plug - Cast Gray Iron, ASTM A126 Class B (Semi-Steel)
Elastomer Seal	Molded, Permanently Lubricated
Elastomer Seal Inserts	Elastomer, Bonded to C-1018 Steel Plate
Retainer Ring	TFE Coated Type 304 Stainless Steel
Bonnet Seal O-Ring	BUNA-S for Gas Service Applications
Spring	Oil-Tempered Steel to ASTM A-229 Specifications
End Gasket	BUNA-S For Gas Service
Retainer Cup	Stainless Steel
Grip Ring	Nickel Plated Per ASTM B733

Style 275 Meter Valve

The most reliable, compact and economical gas meter valve

- The valve body and plug are high grade malleable or ductile iron.
- Factory-installed, permanent lubrication for maintenance-free service.
- The design is tamper proof.
- The valve stem is dual O-Ring sealed. One O-Ring provides a positive pressure seal to the atmosphere, while the other seals against moisture intruding between the body and bonnet.
- The bottom of the valve body is solid, eliminating any leak path to the atmosphere.
- The lock-wing is an integral part of the plug.
- Each valve body features a boss to accommodate a 1/8" IPS tap for testing.
- The valve meets all requirements of ANSI B 16.33-81 and conforms to DOT 192.

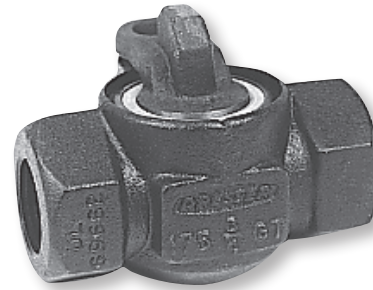

The Dresser Style 275 gas meter valve is a maintenance-free, compact and reliable positive shutoff valve. Rated for operating pressures from inches of water column to 175 psig, the Style 275 is available in sizes 3/4", 1" and 1-1/4", Lock-wing FIPS, and insulated union lock-wing configurations.

Operating Principle

The Style 275 incorporates a spring-loaded seat, plus a self-sealing feature that increases sealability as operating pressure increases. At low pressures, the leaf-type springs exert pressure to force the elastomeric-coated insert into a positive sealing position.

At higher pressures, the valve is designed to employ the gas line pressure to impose a supplemental compressive loading against the seals. The higher the line pressure, the greater the sealing force. Since this force can be exerted on either seal, the valve is non-directional.

Standard Coating

The Style 275 is supplied with black e-coat or zinc phosphate finish as standard that can be used as either the prime coat or the sole coating, depending on service conditions. Salt-spray tests have shown these coatings to provide excellent corrosion resistance.

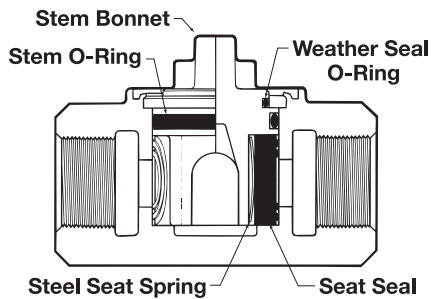

Material Specifications

Body and Stem Bonnet	High Grade Malleable or Ductile Iron
Weather Seal O-Ring	BUNA-N Rubber
Stem Seal O-Ring	BUNA-S Rubber
Retaining Seats	BUNA-N Rubber
Retaining Seat Pads	Ferrous Powder Metal
Retainer Seat Spring	Type 304 Stainless Steel

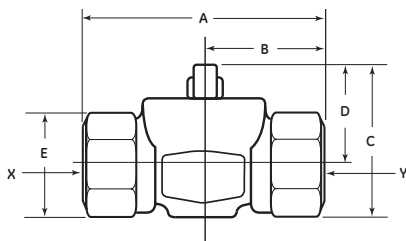

Style 275 Meter Valve Specifications					
Size X & Y (in)	A (in)	B (in)	C (in)	D (in)	E (in)
3/4	3-3/8	23/32	2-17/32	1-5/8	1-7/8
1	3-7/8	3/4	2-29/32	1-13/16	2-1/8
1-1/4	4-1/4	13/16	3-11/32	2-1/32	2-7/16

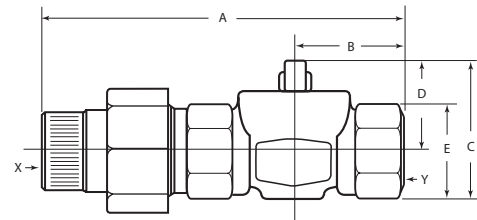
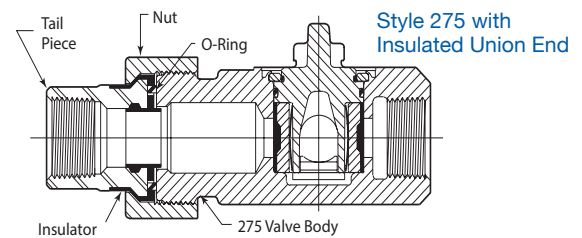

Style 275 Meter Valve Specifications with Insulated Union End

Size X & Y (in)	A (in)	B (in)	C (in)	D (in)	E (in)
3/4	5-25/32	23/32	2-17/32	1-5/8	1-7/8
1	6-5/8	3/4	2-29/32	1-13/16	2-1/8
1-1/4	7	13/16	3-11/32	2-1/32	2-7/16
3/4x1-1/4	7	13/16	3-11/32	2-1/32	2-7/16

Style 350 Ultraseal Flanged Meter Valve

For use in Dresser prefabricated gas distribution meter sets

- Permanently lubricated: Saves the time and hassle of re-lubrication. Designed to prevent freeze-up or blocking of meters with lubricant.
- Bi-directional: The valve can be installed in either direction.
- Bubble-tight seal: After qualification testing to over 10,000 cycles, the valve sealed bubble-tight at -30°F under both low and high pressure.
- Temperature ratings: -20°F to 150°F.
- High flow capacity: Open position provides optimum flow capacity, meeting applicable sections of ANSI B16.33 or B16.38.
- 100% Tested: Each valve is extensively tested to ANSI B16.33 or B16.38 requirements prior to shipping.
- Locking plate: Standard locking plate is available for lock-on/lock-off applications.
- Body and plug construction: Valves are ruggedly constructed of ductile iron.
- Epoxy coated: This is standard for excellent corrosion protection.
- 2" square operating nut: This feature is offered as an option.

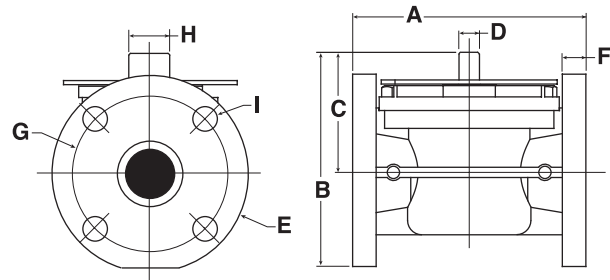
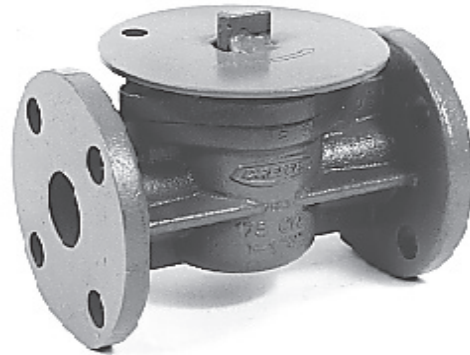

Style 350 Ultraseal Flanged Valve Specifications										
Size (in)	Length A (in)	Height B (in)	Center C (in)	D (in)	E (in)	F (in)	G (in)	H (in)	I (in)	Bolt Holes
2	7	6-9/16		5/8	6	5/8	4-3/4	1-1/4	3/4	4

Material Specifications	
Body and Top Plate	Ductile Iron, ASTM A536 GR 65-45-12
Plug	Ductile Iron, ASTM A536 GR 65-45-12
O-Ring Seals	SBR - Especially Compounded for Long Life in Natural Gas Service
Metallic Atmospheric Seal	18-8 Stainless Steel
Springs	Stainless Spring Steel
Cap Screws	Steel, ASTM A193 Grade B5
Torque Ring	Elastomer
Port Seals	SBR Rubber Molded Over High Tensile Strength Steel
Weather Seal	Chloroprene Rubber
Lock Plate	Carbon Steel

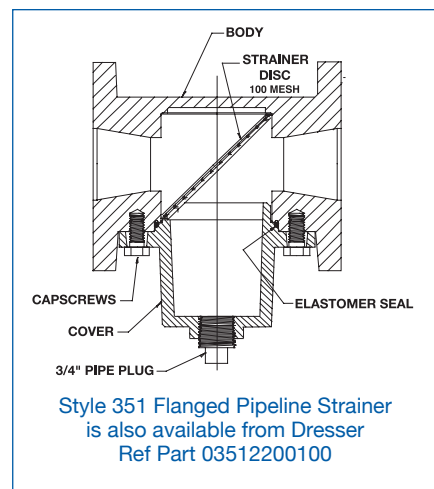

Style 575 Angle Ball Valve

All-In-One Service Tee Connection and Shut-off Valve

The Dresser Style 575 Angle Ball valve provides dual service, as a main-to-service compression end tee connection, and as a shut-off valve.

Constructed of a unique combination of a rugged ductile iron body and a high-strength engineered plastic plug, the 575 valve offers a low torque, 90-degree operation with positive, bottle-tight shut-off at pressures up to 125 PSI. Designed for durability under all service conditions, the valve features an interface of ductile and engineered plastic components, eliminating the possibility of valve freeze-up due to corrosion.

The 575 valve also eliminates the presence of an isolated metallic valve in a plastic service. The ductile material in the valve body is compatible with the cast iron main, so there's no need for anoding and monitoring. Plus, as an option, Dresser offers a custom Plastisol* coating providing an even greater layer of external corrosion protection.

The compression end for connecting the service is of a time-proven Dresser design and meets all the requirements of DOT 192.281(e), providing a permanent seal and pull-out resistance greater than the PE tubing in tension.

The 575 valve is available in inlet sizes 1-1/4" or 1-1/2" MIPT and an outlet size of 1-1/8" OD.

*Plastisol coating is a one-part, black thermoplastic polyvinyl chloride and applied over a base coat of heat-cured E-Coat primer

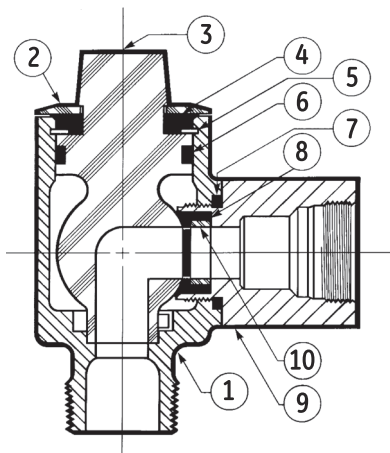
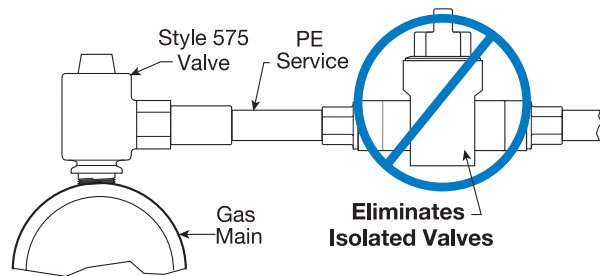

Item	Description
1	Body
2	Bonnet Cap
3	Valve Plug
4	Moisture Seal
5	Retainer Ring
6	O-Ring
7	Branch Gasket
8	Seat Gasket
9	Valve Branch
10	Gasket Retainer

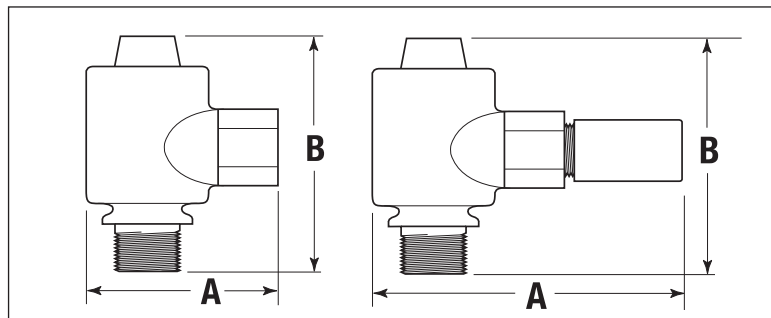

Style 575 Angle Ball Valve Specifications				
Pipe Size Inlet x Branch (in)	Tubing Wall Thickness (in)	A Length 501 End (in)	A Length w/Shield Nut (in)	B Overall Height (in)
1-1/4 MIPT x 1-1/8 OD	.090	5-1/4	5-7/8	4-7/8
1-1/2 MIPT x 1-1/8 OD	.090	5-1/4	5-7/8	4-7/8

Applicable Product Warnings

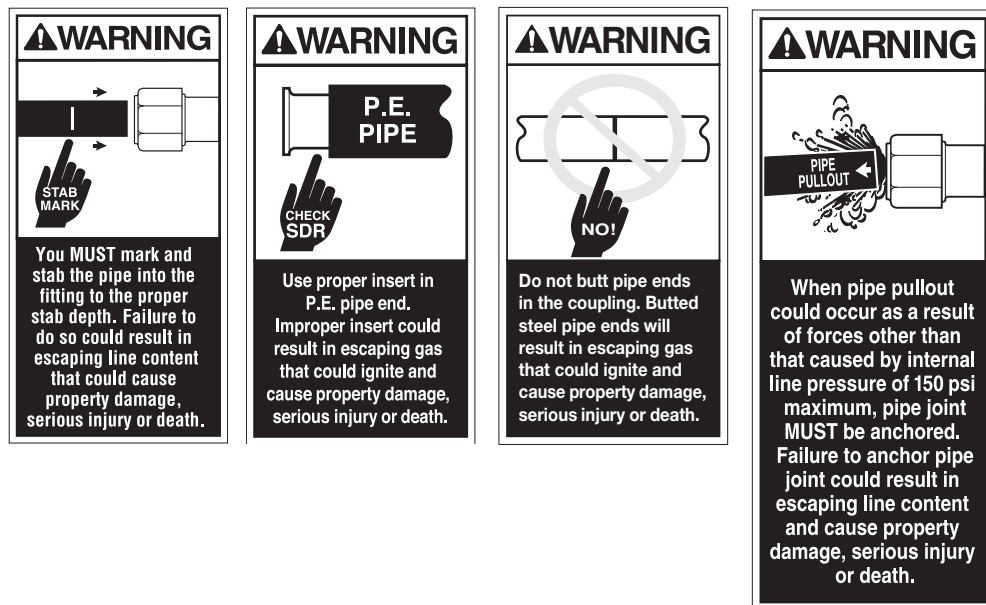

NOTE:

ALWAYS READ THE DRESSER INSTALLATION INSTRUCTIONS AND WARNINGS BEFORE INSTALLING ANY DRESSER PRODUCT!

Visit us at: www.dresserutility.com

Dresser Utility Solutions reserves the right to make changes in specifications and features shown herein, or discontinue the product described at any time without notice or obligation. Contact your Dresser sales representative for the most current information.

Dresser Pipeline Solutions

41 Fisher Avenue
Bradford, PA 16701
T: 814.362.9300
F: 814.362.9344

© 2021 Natural Gas Solutions North America, LLC - All rights reserved. The Dresser Logo and all Trademarks containing the term "Dresser" are the property of Dresser, LLC, a subsidiary of Baker Hughes

DRESSER
PIPELINE SOLUTIONS
www.dresserutility.com

DPS-004
GAS.VALVES.2021