

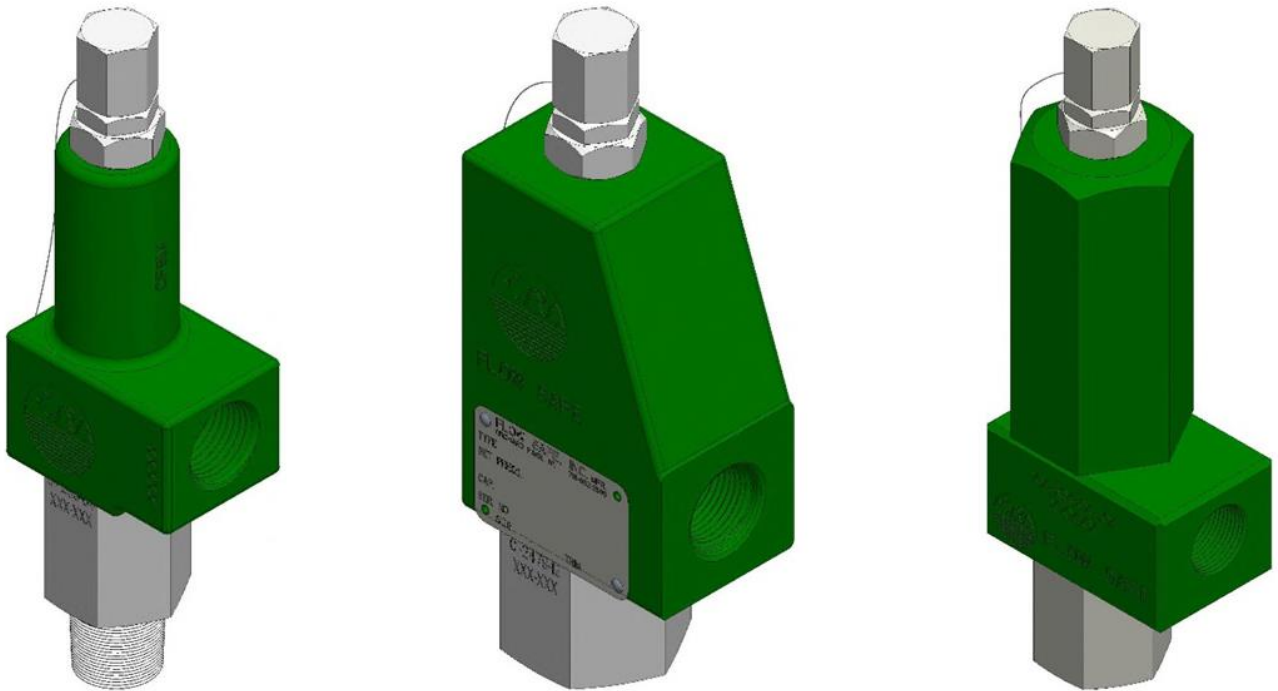

## **F80M (F80 'Micro') SERIES SPRING-OPERATED SAFETY VALVE (GAS)**

- ✓ TYPE F84M (PLASTIC-SEATED)
- ✓ TYPE F85M (ELASTOMER-SEATED)
- ✓ -1, -1A, -2, -3, -4 Orifices



## **INSTALLATION, OPERATION, & MAINTENANCE MANUAL**

Revision:  
Date of Issue:  
Approved By:

K

March 5, 2025

A handwritten signature in black ink that reads "Andrew Roberts".

---

Andrew Roberts  
Director of Engineering & Quality



**TABLE OF CONTENTS**

1.0 GENERAL ..... 3

2.0 DESCRIPTION, OPERATION, SERVICE ENVELOPE, INSTALLATION, and STARTUP ..... 4

2.1 DESCRIPTION / OPERATION ..... 4

2.2 SERVICE ENVELOPE ..... 5

2.3 STORAGE AND HANDLING ..... 5

2.4 INSTALLATION ..... 6

2.4 STARTUP ..... 7

3.0 VALVE MAINTENANCE ..... 7

3.1 DISASSEMBLY OF THE F80M SERIES ..... 7

3.2 REASSEMBLY OF THE F80M SERIES ..... 8

4.0 VALVE TESTING, ADJUSTMENT, & MARKING ..... 8

4.1 TEST EQUIPMENT ..... 8

4.2 SETTING / ADJUSTMENT TOLERANCES ..... 9

4.3 SET PRESSURE and BLOWDOWN ADJUSTMENTS ..... 9

4.4 SEAT TIGHTNESS ..... 10

4.5 SECONDARY PRESSURE ZONE TEST ..... 10

4.6 WIRING, TAGGING, MARKING, & DOCUMENTATION ..... 10

6.0 TROUBLESHOOTING GUIDE ..... 12

## **1.0 GENERAL**

1) This manual is intended to provide users with direction and guidance for the maintenance of FLOW SAFE F80M Series safety valves. This manual indicates the proper method of valve disassembly, soft goods replacement, and valve reassembly. FLOW SAFE provides this manual as a guideline and reference only. It is not intended to serve as a training manual or manufacturing guide. FLOW SAFE assumes no responsibility for personal or property damage that may occur in conjunction with this manual.

2) FLOW SAFE recommends that all valves be placed on a regular maintenance schedule that includes the routine replacement of soft goods. FLOW SAFE recommends soft goods replacement every three years but cautions that each customer make their own determination and set their own schedule based upon use and environment. FLOW SAFE believes that when maintenance and reassembly is performed as outlined in this manual there is no safety hazard.

During routine maintenance the internal components of the valve should be inspected for damage or abnormal wear. The valve should also be inspected for excessive corrosion. A corrosion allowance of 0.06" (1.5 mm) is designed into all carbon steel components subject to corrosion. Operating the valve with corrosion exceeding this allowance is not recommended.

Cycling the valve at least once a year is considered to be good practice to verify operation and to confirm that parts are not seized.

3) When a new valve leaves FLOW SAFE, it has been manufactured and tested by trained and experienced personnel. When a valve is removed from a system for maintenance, proper training of personnel is required.

Do not attempt to accomplish these tasks without adequate training and understanding of the valve operation.

4) Any and all stated or implied warranties that are in effect during the purchase of a new FLOW SAFE valve are null and void once the valve has been disassembled by someone other than approved FLOW SAFE personnel.

All repair and resetting of "UV"-stamped pressure relief valves should be performed either by FLOW SAFE, Inc., or by a National Board-certified valve repair shop holding a "VR" (Valve Repair) or "T/O" (Test Only) stamp. For any repair or resetting of "UV"-stamped valves outside of the scope mentioned in the prior sentence, contact Flow Safe for more information.

5) It is highly recommended that all instructions herein be read in full prior to any assembly, disassembly, or operation of this equipment.

6) The noted manufacturer's standard lubricants shall be used only if compatible with process fluid and application.

7) Specific design details described in this document are subject to change without notice.

8) Should the need arise for general assistance, contact the FLOW SAFE Sales or Service department at (716) 662-2585 or (800) 828-1036 in Orchard Park NY or (832) 678-2070 in Houston TX. For more detailed technical assistance, contact the FLOW SAFE Engineering department at (716) 662-2585.

## 2.0 DESCRIPTION, OPERATION, SERVICE ENVELOPE, INSTALLATION, and STARTUP

### 2.1 DESCRIPTION / OPERATION

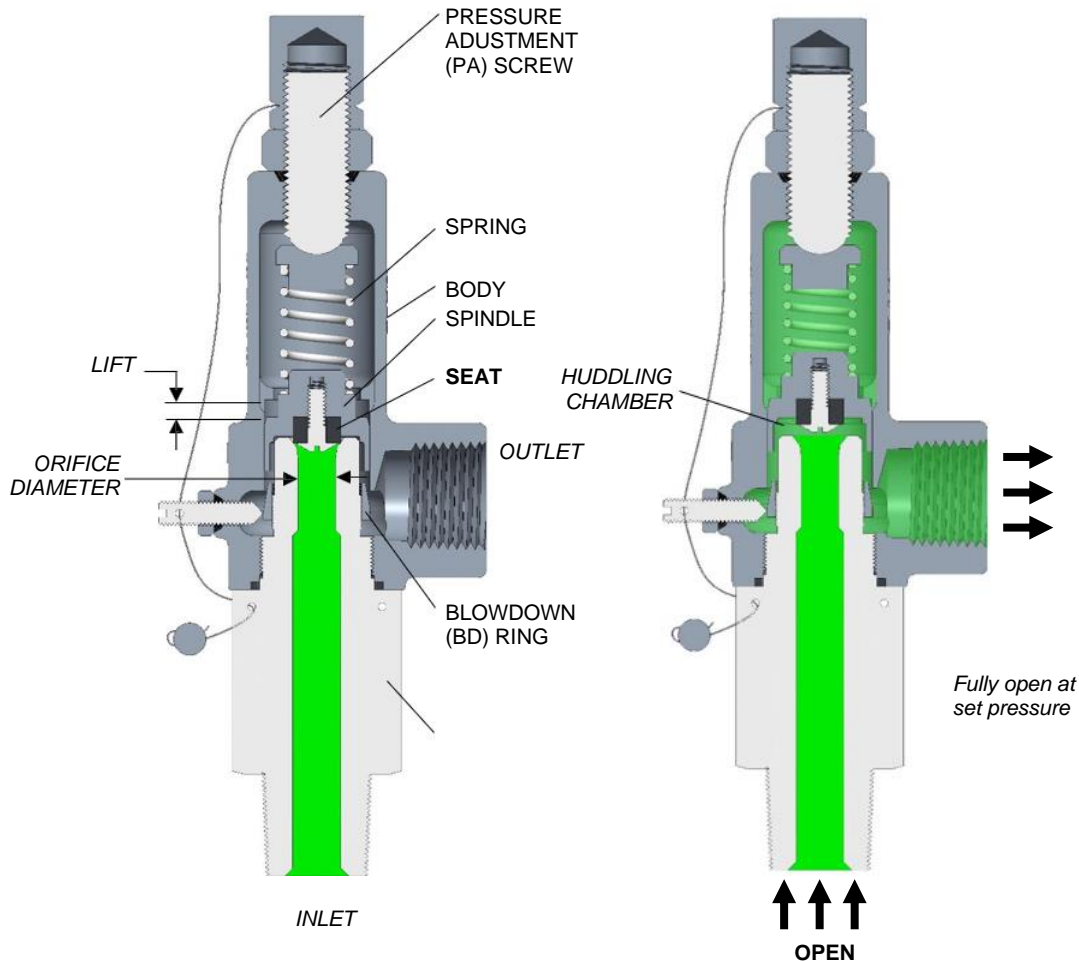

The FLOW SAFE F80M Series safety valve is a direct-acting spring-loaded pressure relief valve, suitable for gas service. The Type F84M is plastic-seated and the F85M is elastomer-seated.

Orifice sizes are available in -1, -2, -3, and -4 with set pressures from 15 to 15,000 psig (depending on the orifice size).

Blowdown, up to approx. 20%, is readily controlled by adjusting the blowdown ring. FLOW SAFE valves set above 25 psig are typically shipped with 7-10% blowdown, allowing the valve to reseal bubble tight to approximately 90-93% of set point. Valves set at or below 25 psig typically have 4 to 5 psig blowdown.

# INSTALLATION, OPERATION, & MAINTENANCE MANUAL



TITLE: F80M (F80 'Micro') Series  
Spring-Operated Safety Valve

Rev. K  
Page 5

## 2.2 SERVICE ENVELOPE

Maximum Set Pressure, psig (barg)	Micro Body Size	Material <sup>4</sup>	ORIFICE SIZE							
			F84M (Plastic-seated)				F85M (Elastomer-seated)			
			-1/-1A	-2	-3	-4	-1	-2	-3	-4
	M (Std)	BR	4,072 (281)	4,072 (281)	890 (61)	350 (24.1)	5,000 (345)	4,072 (281)	890 (61)	350 (24.1)
		SS	4,072 (281)	4,072 (281)	890 (61)	350 (24.1)	6,600 (455)	4,072 (281)	890 (61)	350 (24.1)
	H <sup>2,3</sup> (HP Block)	BR	4,072 (281)	4,072 (281)	890 (61)	350 (24.1)	6,600 (455)	4,072 (281)	890 (61)	350 (24.1)
		SS	4,072 (281)	4,072 (281)	890 (61)	350 (24.1)	10,313 (711)	4,072 (281)	890 (61)	350 (24.1)
	P <sup>3</sup> (HP 2-PC)	BR	---	---	---	---	---	---	---	---
		SS	15,000 (1,034)	15,000 (1,034)	---	---	---	9,944 (685)	---	---

<sup>1</sup> 6100 psig (420 barg) with 1/2" or 3/4" FNPT inlet

<sup>2</sup> Commonly used when an MS or SAE outlet thread is required, regardless of set pressure

<sup>3</sup> Can be used for any orifice at lower set pressures, when required

<sup>4</sup> Standard material configuration codes: BR = Bronze, SS = Stainless Steel

SEAT MATERIAL	Temperature, °F (°C)	
	MIN. <sup>4</sup>	MAX.
<b>F84M (Plastic-seated)</b>		
Teflon® (PTFE)	-423 (-252)	400 (204)
Kel-F (PCTFE)	-423 (-252)	400 (204)
Polyimide or Polyamide-imide: Vespel®, Duratron®, or equal	-423 (-252)	500 (260)
Polyetheretherketone (PEEK)	0 (-18)	525 (274)
<b>F85M (Elastomer-seated)</b>		
Buna-N	-30 (-34) <sup>5</sup>	275 (135)
Fluorocarbon: Viton® or equal	-30 (-34)	400 (204)
Ethylene propylene (EPR/EPDM)	-65 (-54)	325 (163)
Perfluoroelastomer: Kalrez®, Chemraz®, or equal	0 (-18)	525 (274)
Polyurethane	-60 (-54)	225 (107)

<sup>4</sup> Confirm service / application with factory.

<sup>5</sup> -65°F (-54°C) with low temp nitrile

## 2.3 STORAGE AND HANDLING

### A. STORAGE

Prior to installation, Flow Safe valve assemblies and parts shall be stored in a clean, dry environment. Inlet and outlet connections shall remain covered until the item is ready for installation.

For outside storage, protection from the elements is required. Exposed carbon steel surfaces shall remain coated with a suitable rust inhibitor until the assembly is ready for installation.

Even though elastomers and lubricants in the relief valve typically have a long shelf life and can be used in environments down to -40 °F/-40 °C, operability of the main piston shall be checked before placing the valve in service after extended storage. See Section 2.4.

## B. HANDLING

Flange facings and other gasket sealing surfaces shall be isolated from contact with other hard objects through the use of cardboard or other soft materials. Placing flanged surfaces directly on wooden skids shall be avoided.

## 2.4 INSTALLATION

Prior to installation, check that the set pressure on the nameplate is as required, and meets the system requirements.

The F80M Series safety valve shall be installed in the upright position per the figure below with the inlet facing down, as close as possible to the pressure source, to minimize pressure losses between the system and the valve. This shall be in accordance with accepted piping practices, as set forth in the API 520 Part II, which recommends that inlet piping pressure losses should not exceed 3% of the set pressure when the valve is flowing.

The valve discharge pipe should be sufficiently large so that built-up backpressure does not exceed 10% of the set pressure when relieving. Higher backpressures may cause the valve to chatter (rapid cycle), or affect capacity.

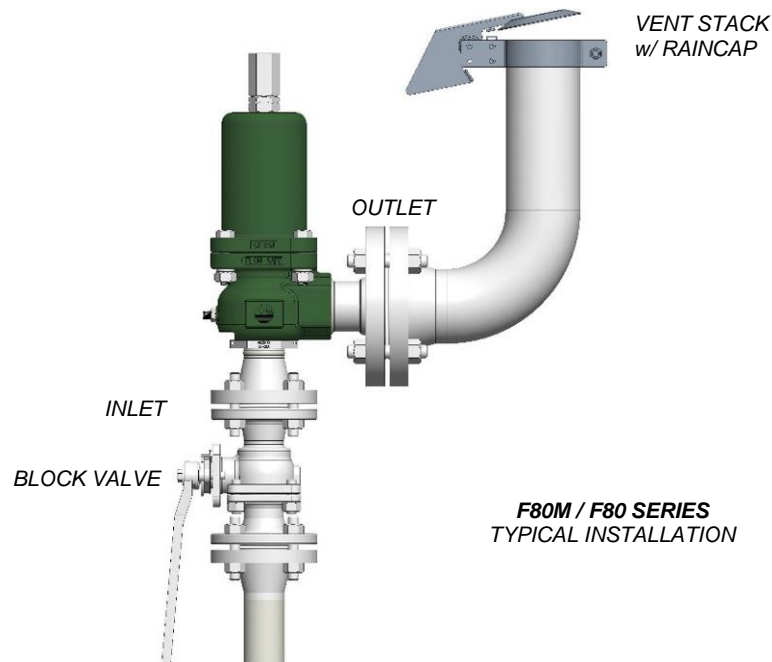

The F80M Series valves are **not** balanced against superimposed backpressure, so that the set pressure will change one-for-one with the backpressure. This means that for each 1 psi of superimposed backpressure, the set pressure will increase by 1 psi. Refer to Section 4.3 for setting instructions. **Check the valve manufacturer's nameplate(s) to determine if the valve was already set with a correction for backpressure (cold differential test pressure [CDTP]).**

Ensure that the inlet piping / flanges have an opening equal to or greater than the valve's inlet diameter. Make sure that there are no obstructions such as gaskets, fittings, etc., in the flow path to restrict the flow or cause chatter. Also, misaligned piping connections may result in leaks or induce stresses in the valve assembly that interfere with good operation. Discharge stacks exposed to the elements should be configured so as to avoid the accumulation of ice and snow.

If a block valve is used below the pressure relief valve, it should be opened before pressurizing the system. This block valve should be locked open during normal system operation.

Use only the wrench flats on the valve inlet bushing, taking care not to make any wrench marks, for tightening and installation. Do not wrench on cast body or bonnet.

## **2.4 STARTUP**

Foreign particles or dirt can damage the valve and make it inoperative. Prior to installation, clean out the piping thoroughly. If the valve is not installed immediately, inlet and outlet connections should be protected and covered.

Pressure can be applied to the valve as system pressure increases, or by opening the block valve (if there is one) after the system has attained operating pressure. Verify the valve seat is leak-tight, in accordance with Section 4.4.

The valve is now ready for service. Inspection and maintenance should be performed on a regular basis, typically once a year, depending on the service conditions.

## **3.0 VALVE MAINTENANCE**

**WARNING:** It is extremely dangerous to attempt to disassemble any valve while it remains in service with incoming line pressure. Also, improper assembly of the valve may result in leakage or failure of the valve when returned to service.

### **3.1 DISASSEMBLY OF THE F80M SERIES**

(See Illustrations on pages 13 through 18)

- 1) Remove the valve from service, or adequately and safely block the incoming pressure before disassembling the valve and performing maintenance.

**NOTE:** If bushing remains connected to the system piping, then the valve's internal components (spring, washer, spindle) will fall out of the body as it is removed.

- 2) Cut and remove the lockwire.
- 3) Remove the pressure adjusting (PA) screw cap. Measure height of PA screw above body and record value. Loosen the PA screw jam nut. Loosen PA screw until spring load is removed.
- 4) Record gap between bottom of blowdown (BD) ring and bushing shoulder. Then loosen the BD
- 5) lock nut and lock screw.
- 6) Unscrew and remove the bushing, using wrench flats.
- 7) If valve has a 'P' 2-piece body / bonnet, unscrew the bonnet from the body. This will expose the spring, spring washer(s), and lower end of the PA screw.
- 8) Remove the spindle assembly. Remove retainer screw / retainer (as applicable) and seat.
- 9) Remove spring washer and spring.
- 10) Replace soft goods per the instructions in Section 3.2.

Replacement parts may be found in the appropriate FLOW SAFE soft goods kit, as listed in Section 5.0 of this manual.

## **3.2 REASSEMBLY OF THE F80M SERIES**

**NOTE:** Care must be taken in handling of all items, particularly soft goods and nozzle surfaces.

- 1) Apply Neverseez or DuPont Krytox (for oxygen service) to all straight threads.
- 2) Complete seat assembly as follows:
  - a. **F84M:** Insert the plastic seat into the spindle. Apply Loctite or Vibra-tite to retainer screw threads (if applicable). For the F84M-1/-1A and F84M-2 (above 890 psig) with push-in seat (no retainer screw), the radiused or chamfered edge of the seat must be facing out; push the seat squarely into the spindle cavity using a clean finger or other soft surface. Do not nick or scratch the sealing edge. The set screw should be installed flush with the top of the spindle. The F84M-2 (15-890 psig), -3, and -4 uses a retainer screw to hold the seat in place. Install the seat dry. Tighten retainer screws firmly.
  - b. **F85M:** Insert the O-ring seat into the spindle. To ease seat installation, apply a light coat of Dow Corning Molykote 33 (or 55) or Krytox (for oxygen service). The F85M-1, -2, and -3 uses a threaded retainer that enters the top of the spindle. The F85M-4 uses a retainer screw. Apply Loctite or Vibra-tite to all threaded retainers and fasteners, and tighten firmly. Older spindle designs may be fitted with a push-in retainer. The retainer must fit tight as it is pushed in against the seat (tapered end inward). If fitted with a set screw, install the screw in the top of the spindle.
- 3) Assemble the spring washer(s) and spring into the body.
- 4) Insert the spindle assembly into the body, making sure that it travels freely on the guide surface.
- 5) Screw the BD ring onto the bushing, to the same gap as previously recorded.
- 6) Position the bushing seal on the appropriate shoulder of the bushing.
- 7) Screw the bushing / seal / BD ring assembly into the body and tighten using the wrench flats.
- 8) For models with a 'P' 2-piece body / bonnet, check placement of the Teflon crush ring in the bonnet recess near the threads and tighten the bonnet onto the body.
- 9) Screw the PA screw, lock nut, and seal into the top of the body, with screw at previously recorded height.
- 10) Screw the BD ring lock screw, lock nut, and seal into the back of the body.
- 11) The valve is now completely assembled and ready to be tested. See Section 4.0.

## **4.0 VALVE TESTING, ADJUSTMENT, & MARKING**

The following tests and adjustments are necessary for gas service valves: set pressure, reseal pressure (blowdown), and seat tightness.

### **4.1 TEST EQUIPMENT**

Where practical, a sufficiently large accumulator or pressure vessel should be used to read and set blowdown. At a minimum a four (4) ft<sup>3</sup> vessel is recommended for the -1/-1A orifice to 10,313 psig, -2 orifice to 4,072 psig, -3 to 890 psig, and -4 to 350 psig. The supply pipe should have an ID equal to or greater than the valve's orifice diameter, and should be no more than 10" long. For scope outside of the pressures listed, contact your Flow Safe representative.



## **4.2 SETTING / ADJUSTMENT TOLERANCES**

<b><u>Set Pressure:</u></b>	<b><u>Set Pressure</u></b>	<b><u>Tolerance</u></b>
	> 70 psig	<b>± 3%</b> of specified set pressure
	≤ 70 psig	<b>± 2 psi</b>

**Seat Tightness:** Seat tightness must be tested per the below (ref. API 527). See API 527 for bubble cup dimensions/criteria.

**Inlet pressure requirements:**

- 90% nameplate set pressure, if set pressure > 50 psig
- 5 psi below nameplate set pressure, if set pressure < 50 psig

**Hold Period:**

- Inlet pipe size of 2" or smaller: 1 minute
- Inlet pipe size of 2.5" to 4": 2 minutes
- Inlet pipe size of 6" or larger: 5 minutes

**Leakage observation time (i.e. zero bubbles):**

- 1 minute

## **4.3 SET PRESSURE and BLOWDOWN ADJUSTMENTS**

- NOTES:**
- a) If the set pressure is changed more than + 5% from the nameplate set pressure, then the spring, spring washer, PA screw, body, and bonnet may need to be changed. Consult the factory or an authorized FLOW SAFE assembler for the correct parts.
  - b) If the valve must be set to compensate for constant superimposed backpressure, the set pressure to be used on a test stand ('cold differential test pressure' or CDTP – with zero backpressure) is obtained by subtracting the amount of backpressure from the desired in-service set pressure.

Example:      Desired set point (in service):    100 psig  
                    Superimposed backpressure:    10 psig  
                    CDTP (*without backpressure*):    90 psig

- 1) Remove the PA screw cap (if installed), loosen the PA screw lock nut, and screw the PA screw in (clockwise) to approximately the height recorded in 3.1.3.
- 2) Increase the inlet pressure until the valve opens then let the pressure drop until the valve re-seats. Properly isolate the test valve from the inlet pressure, deplete pressure remaining between isolation valve and test valve, and make PA screw adjustments based on the previous pop (i.e. if the initial pop was low, screw the PA screw inwards [clockwise] and if the initial pop was high, screw the PA screw outwards [counterclockwise]). Continue to readjust as required until the valve demonstrates consistent opening operation at set point per 4.2.
- 3) If blowdown can be accurately measured on the test stand (see 4.1), ensure that the blowdown is still accurate to customer requirements by following the following steps.
  - a. Be sure the blowdown lock screw and lock nut are loosened.
  - b. Raise or lower the blowdown ring using a screwdriver through the valve outlet. Raising the ring shortens blowdown; lowering the ring lengthens blowdown.
  - c. Re-tighten lock screw and lock nut after adjustments have been made. Tighten lock screw firmly into blowdown ring knurls enough to prevent ring from turning.

If blowdown can be accurately measured on the test stand and customer requirements for blowdown have not changed, the blowdown ring gap as-received from assembly is acceptable.

If blowdown cannot be accurately measured on the test stand and customer requirements for blowdown have changed, contact the factory for customized BD ring gap settings.

- 4) Install and tighten down the PA screw cap. Test valve at least one more time to verify pop pressure and blowdown.

#### **4.4 SEAT TIGHTNESS**

- 1) After any repairs and set pressure adjustments, seat tightness shall meet the criteria stated in Section 4.2.
- 2) If the valve leaks after repair refer to the troubleshooting guide in Section 6.0. Check for:
  - d. Even seating between the spindle and bushing. With the F84M's, a full circular witness mark should be visible on the conical bushing surface. Make sure that the seat is installed all the way in the spindle and that the retainer is tight.
  - e. Foreign particles trapped between the seat and bushing. If found, they may have damaged the seat, requiring that it be replaced.
  - f. Scratches on the seating area of the bushing. On the F84M, this is the top beveled surface, near the ID. On the F85M, this is the top crown on the bushing.

#### **4.5 SECONDARY PRESSURE ZONE TEST**

- 1) Connect a flange or threaded plug with tubing connection into the valve outlet. The test valve shall remain in the vertical orientation.
- 2) Apply a minimum of 30 psig, or as otherwise designated by the sales order, using dry shop air. For values above this, contact Flow Safe to ensure that design ratings are not exceeded.
- 3) Hold the pressure for at least 1 minute and conduct a visual examination for leakage by spraying the body and bonnet with soapy water. No leakage is acceptable. There should be no permanent deformation or yielding observed.
- 4) De-pressurize and wipe valve dry.

#### **4.6 WIRING, TAGGING, MARKING, & DOCUMENTATION**

- 1) Where applicable, repair organization standard operating procedures regarding lock wire, tagging (including the creation and affixing of a new "VR" nameplate), marking, and valve documentation shall be followed.

# INSTALLATION, OPERATION, & MAINTENANCE MANUAL



TITLE: F80M (F80 'Micro') Series  
Spring-Operated Safety Valve

Rev. K  
Page 11

## 5.0 SOFT GOODS KITS (SGK'S)

NOTE: Provide valve serial number(s) whenever possible when ordering soft goods kits

Orifice	Kit Part Number			
	F84M		F85M	
	M / H Bodies	P Body	M / H Bodies	P Body
- 1 / -1A	F84M-1-XT	F84M-2H-XT	F85M-1-DXT	F85M-1H-DXT
- 2 ( ≤ 890)	F84M-2L-XT	F84M-2L-XT	F85M-2-DXT	F85M-2H-DXT
- 2 ( > 890)	F84M-2H-XT	F84M-2H-XT	F85M-2-DXT	F85M-2H-DXT
- 3	F84M-3-XT	F84M-3H-XT	F85M-3-DXT	F85M-3H-DXT
- 4	F84M-4-XT	F84M-4H-XT	F85M-4-DXT	F85M-4H-DXT

Code	F84M	F85M	D = Seat Hardness (F85M)	
T	Teflon	---	5	Soft: ≤ 50 psig
K	PCTFE / Kel-F	---	7	Medium: 51-999 psig
W	Vespel / PI / PAI	---	9	Hard: ≥ 1000 psig
P	PEEK	---	0	"Universal": 1 each of above seats
F	EkonoI-filled Teflon	---		
B	---	Buna-N		
V	---	Viton		
U	---	Polyurethane		
E	---	EPR / EPDM		
Z	---	Kalrez		
C	---	Chemraz		
N	---	Lo-temp nitrile		

Most common seat materials listed; contact Flow Safe for availability of other materials.

Seat hardness vs. set pressure listings for F85 are approximate only.

"T" in kit part number indicates seals are Teflon.

## SOFT GOODS KIT CONTENTS (See pages 13 through 18)

Qty.	Description
1*	Seat
1	Bushing Seal
1	PA Screw Seal
1	Blowdown Lock Screw Seal
1**	Bonnet Seal

\* Additional seats provided with "universal" kit

\*\* 'P' 2-PC HP bodies only

## 6.0 TROUBLESHOOTING GUIDE

Symptom	Possible Cause	Remedy
The valve leaks around the bushing.	Inadequate bushing torque.	Tighten until the bushing bottoms firmly on the body.
	Sealing surface on body or bushing is damaged.	Inspect and polish sealing surfaces.
	Bushing seal is damaged or contaminated.	Remove bushing seal. If damaged, replace with new seal. If contaminated, clean and replace.
The valve leaks through the outlet.	Seat or nozzle seating surface is damaged or contaminated.	Disassemble the valve, remove the spindle, and examine the seat and seating surface under magnification. If damaged, replace with new seat; if contaminated, clean and reinstall.
The valve does not close.	The spindle is stuck.	Disassemble and check for binding. Deburr or replace parts.
The valve opens below the designated set point.	The spring preload is low due to misadjustment, vibration, or other.	Adjust pressure adjusting screw in (clockwise). Ensure PA screw lock nut and cap are tight.
	The seat leaks due to possible damage, allowing early simmer and pop.	Disassemble and inspect seat; replace if damaged.
The valve opens above the designated set point.	The spring preload is high.	Adjust PA screw out (counterclockwise).
	The spindle is stuck or sticking	Disassemble and check for binding. Deburr or replace parts. Check for a permanent nozzle impression in the O-ring seat (F85M). Replace or contact factory.
The valve does not open.	Spindle is stuck closed.	Disassemble the valve and examine the sliding surfaces. If damaged, replace. If contaminated, clean.
	Nozzle stuck to seat.	Disassemble and check seat for permanent impression. Replace O- ring seat (F85M) with harder material.
	The set pressure has not been reached.	Increase inlet pressure. Confirm pressure gage is calibrated.
	Isolation valve is closed.	Open isolation (block) valve.
	There is superimposed backpressure.	Increase pressure until valve pops, or adjust (lower) set pressure (1:1) to compensate for backpressure [See Section 4.3].
The valve chatters or rapid-cycles	The valve is oversized for the application.	Install smaller valve.
	The inlet is choked.	Open the inlet to be equal to or greater than the valve orifice.
	Too much built-up backpressure due to excessive flow, or outlet piping undersized or too long.	At a backpressure equal to approximately 40% of set pressure, chatter / rapid-cycling may start.  Reduce backpressure by reducing flow rate or reworking outlet piping (increase size; shorten; reduce number of turns). It is recommended that outlet piping size be equal to or greater than the valve outlet size.

**F84M SERIES (Plastic-Seated) Valve "M"  
Body (Standard w/ Integral Bonnet)  
ASSEMBLY ILLUSTRATION**

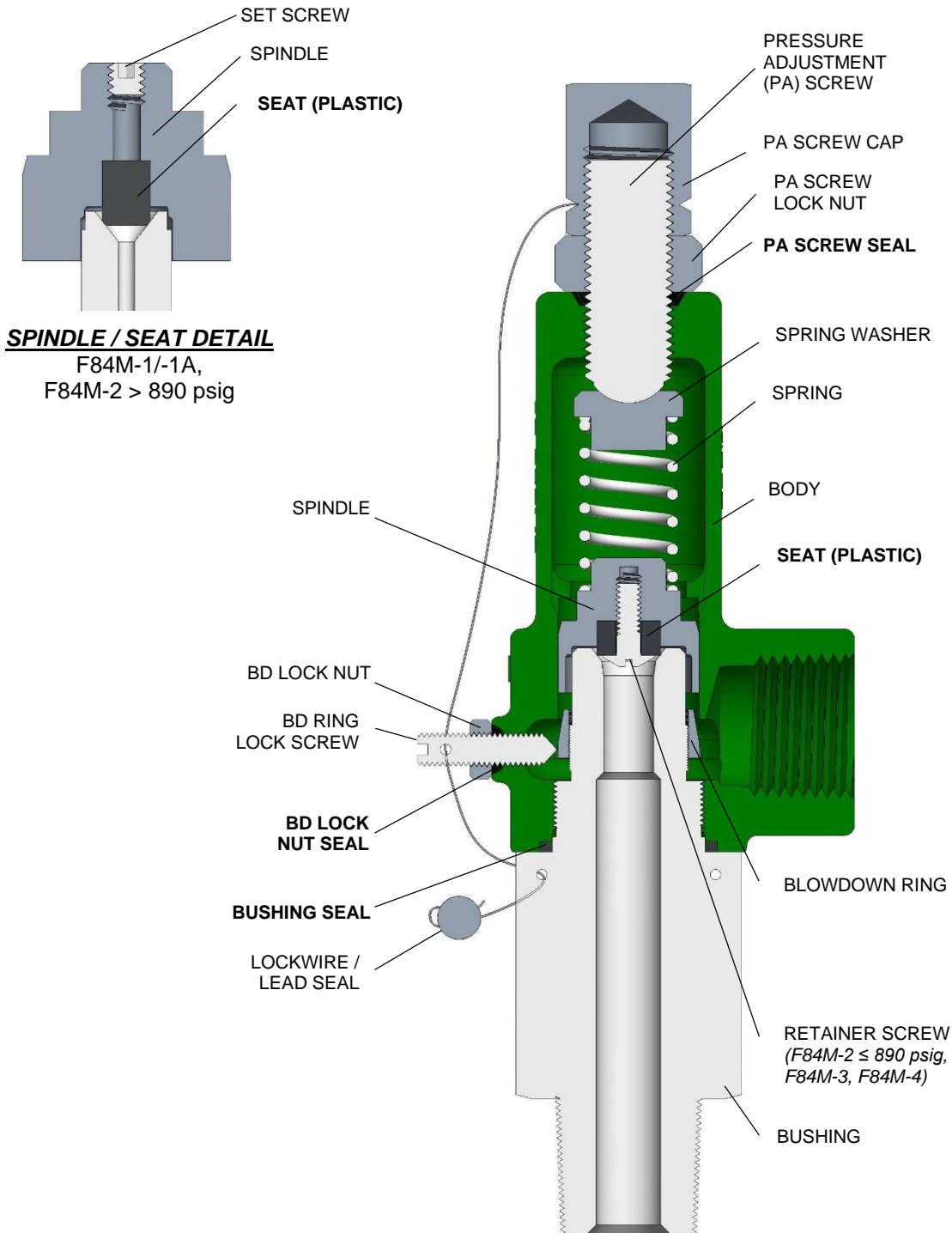

***F84M SERIES (Plastic-Seated) Valve "H"  
Body (HP Block w/ Integral Bonnet)  
ASSEMBLY ILLUSTRATION***

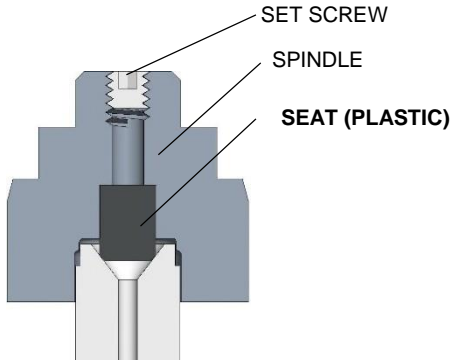

**SPINDLE / SEAT DETAIL**

F84M-1/-1A,  
F84M-2 > 890 psig

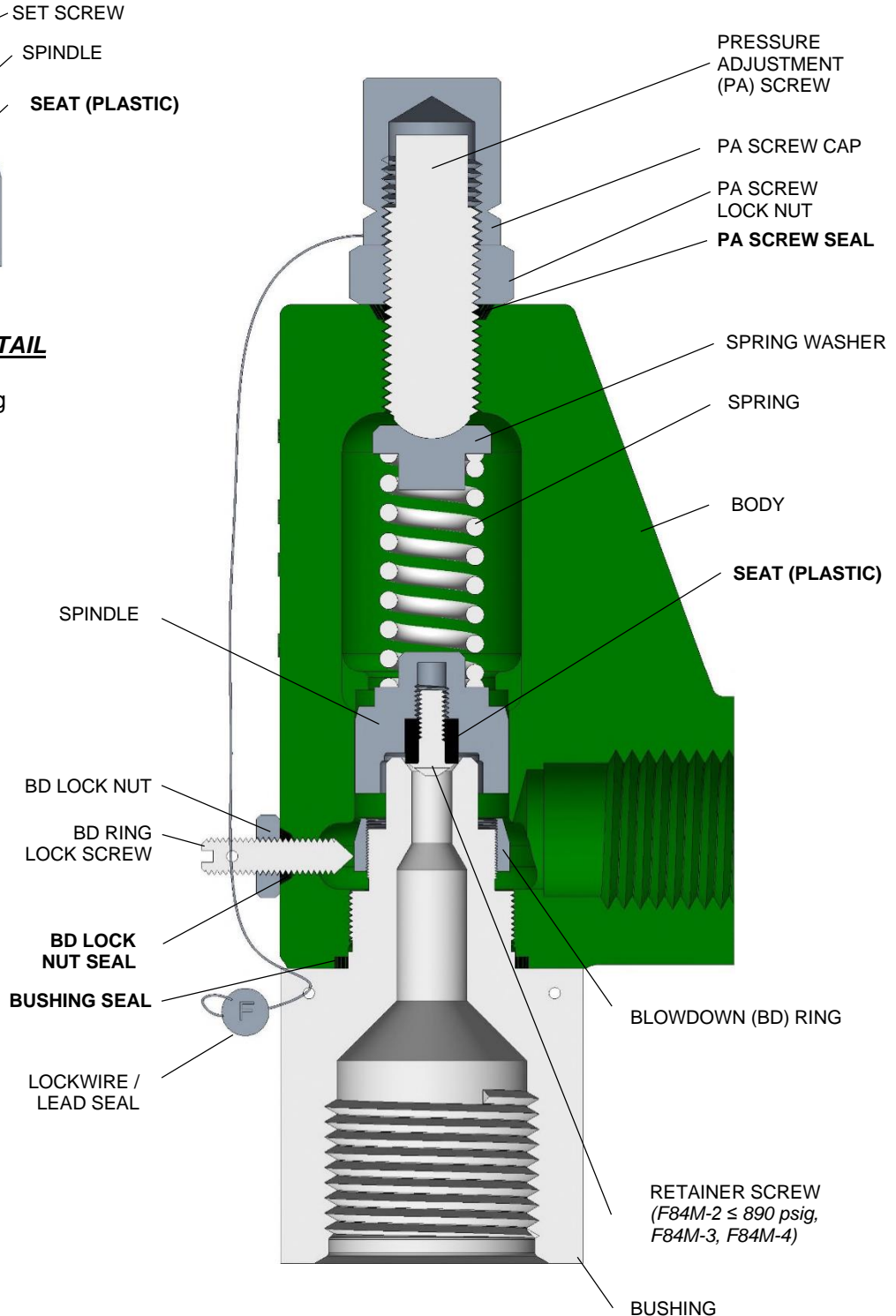

**F84M SERIES (Plastic-Seated) Valve "P"  
Body (2-PC HP w/ Threaded Bonnet)  
ASSEMBLY ILLUSTRATION**

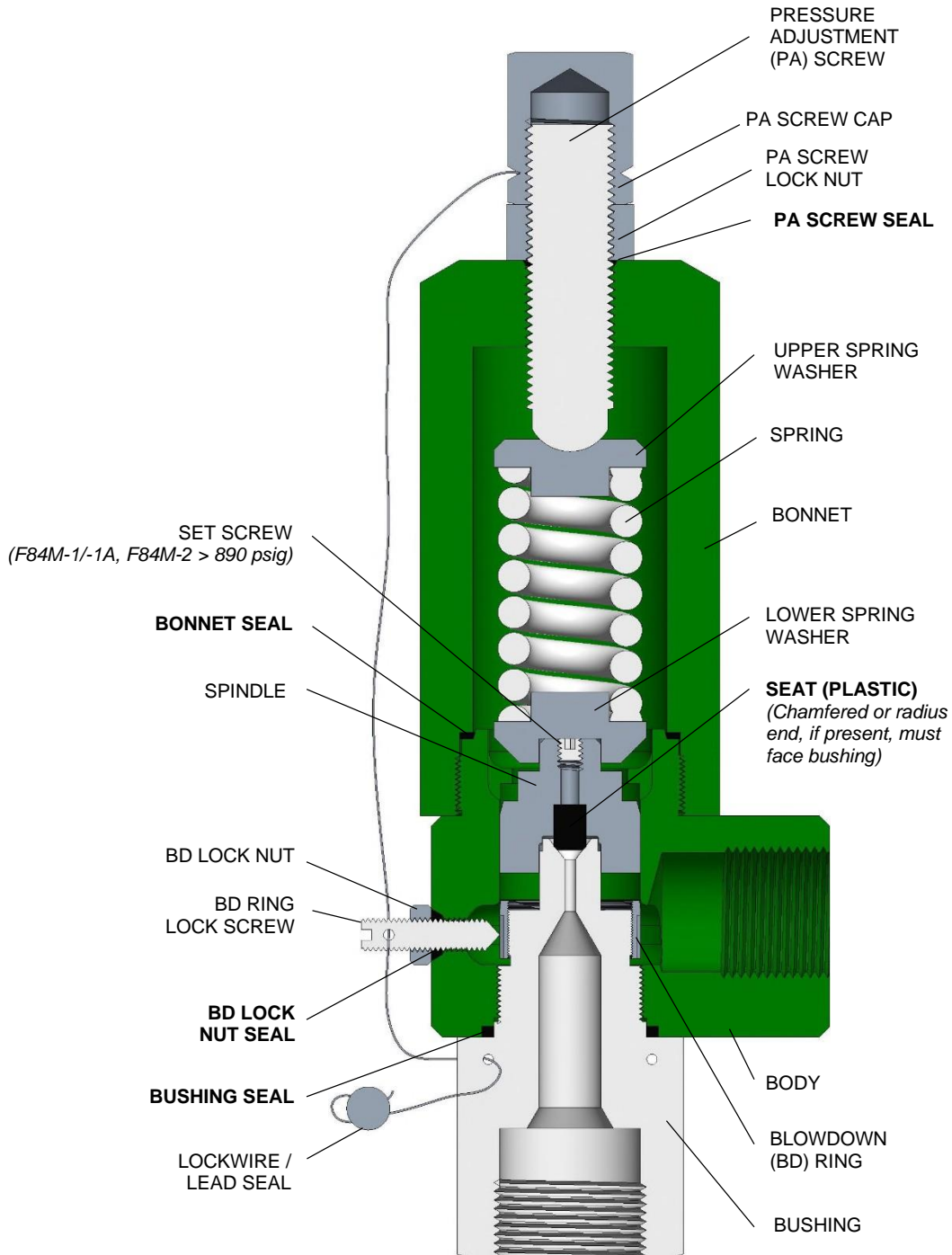

**F85M SERIES (Elastomer-Seated) Valve  
"M" Body (Standard/ Integral Bonnet)  
ASSEMBLY ILLUSTRATION**

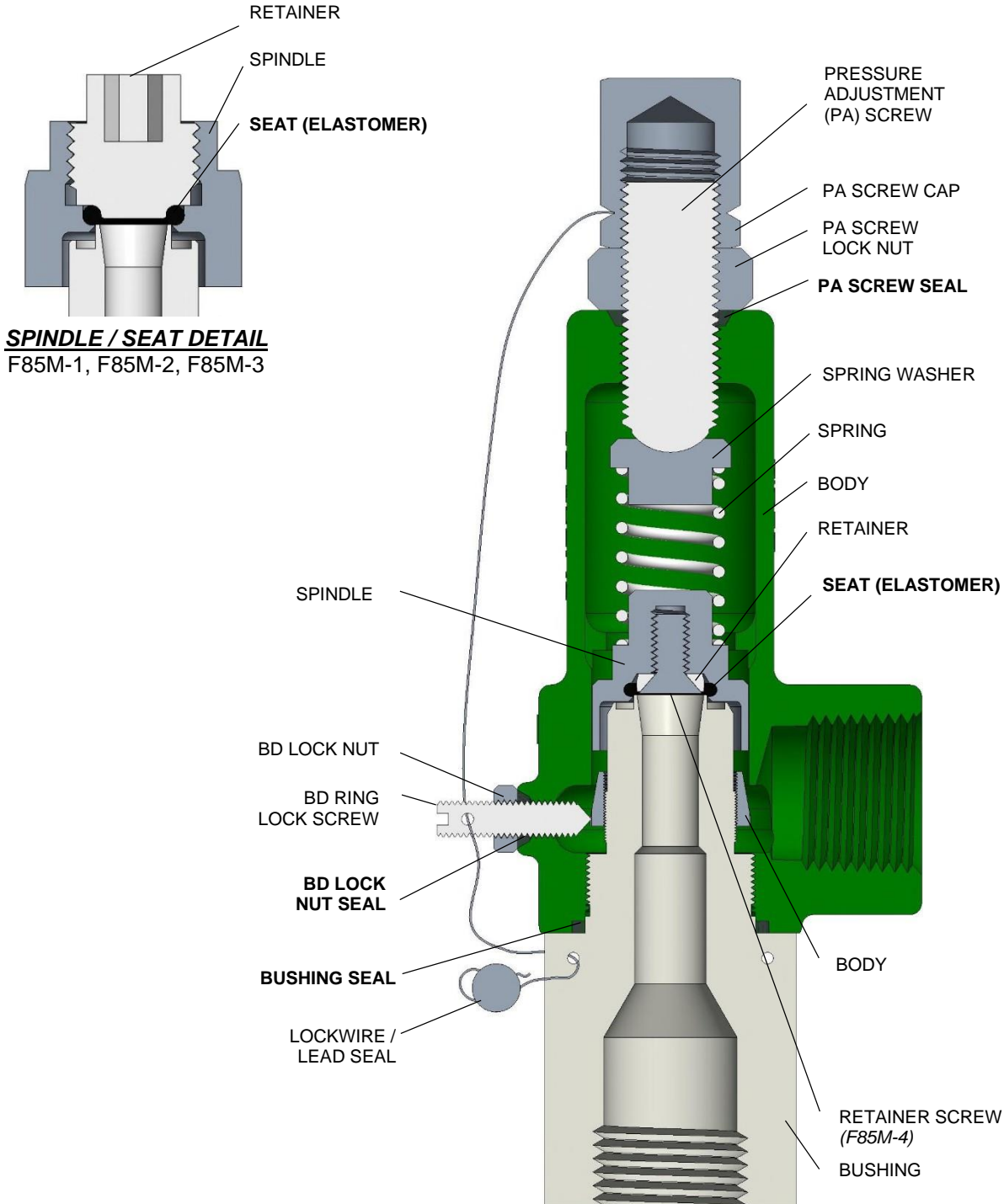



***F85M SERIES (Elastomer-Seated) Valve  
"H" Body (HP Block w/ Integral Bonnet)  
ASSEMBLY ILLUSTRATION***

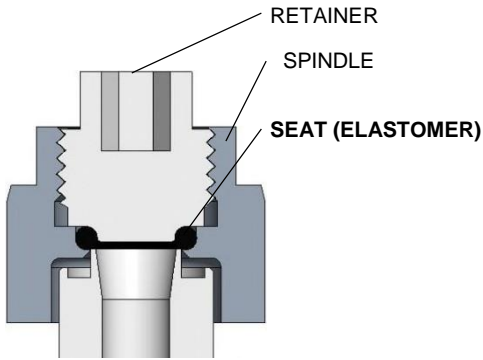

**SPINDLE / SEAT DETAIL**  
F85M-1, F85M-2, F85M-3

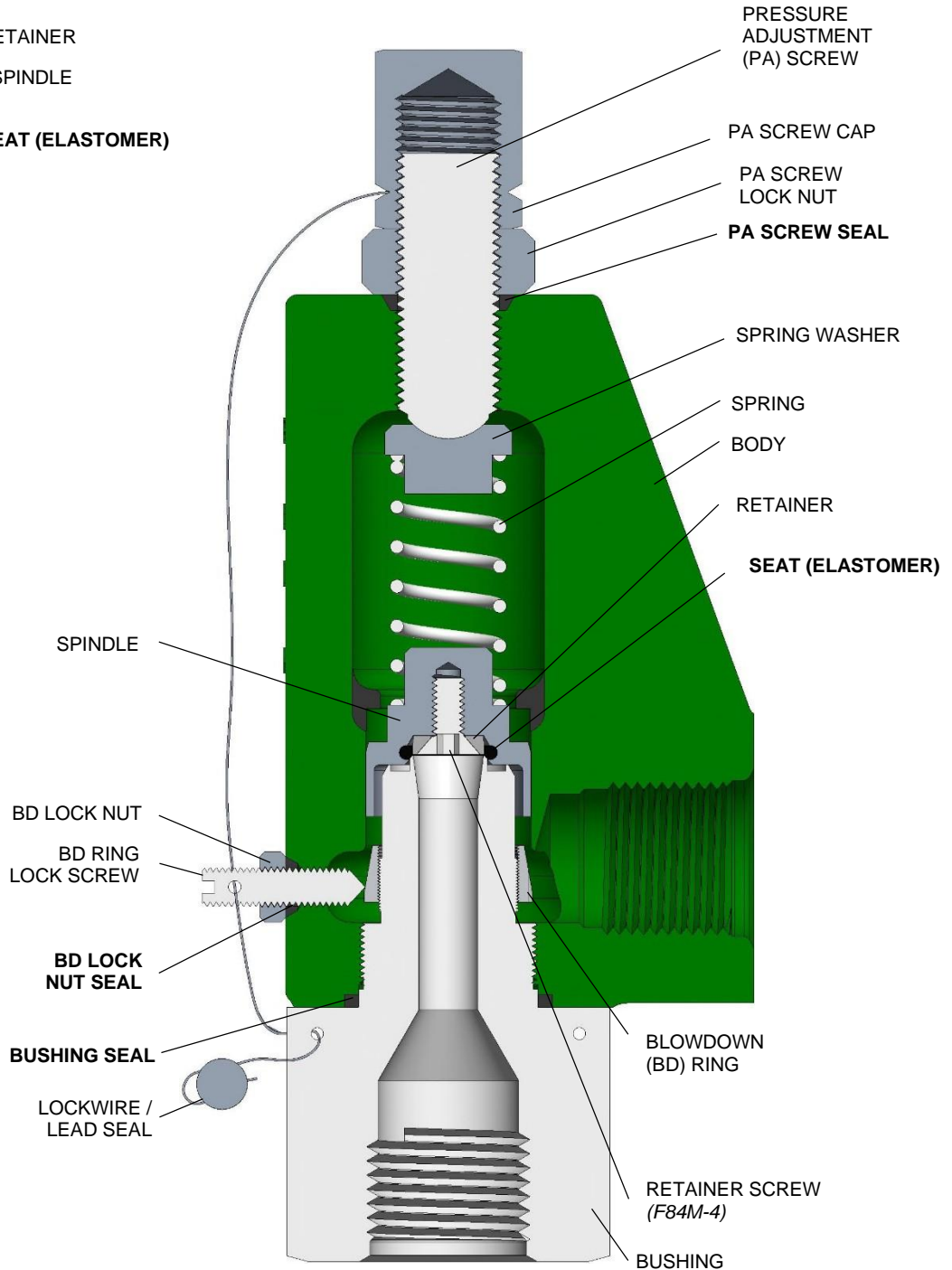

**F85M SERIES (Elastomer-Seated) Valve  
"P" Body (2-PC HP w/ Threaded Bonnet)  
ASSEMBLY ILLUSTRATION**

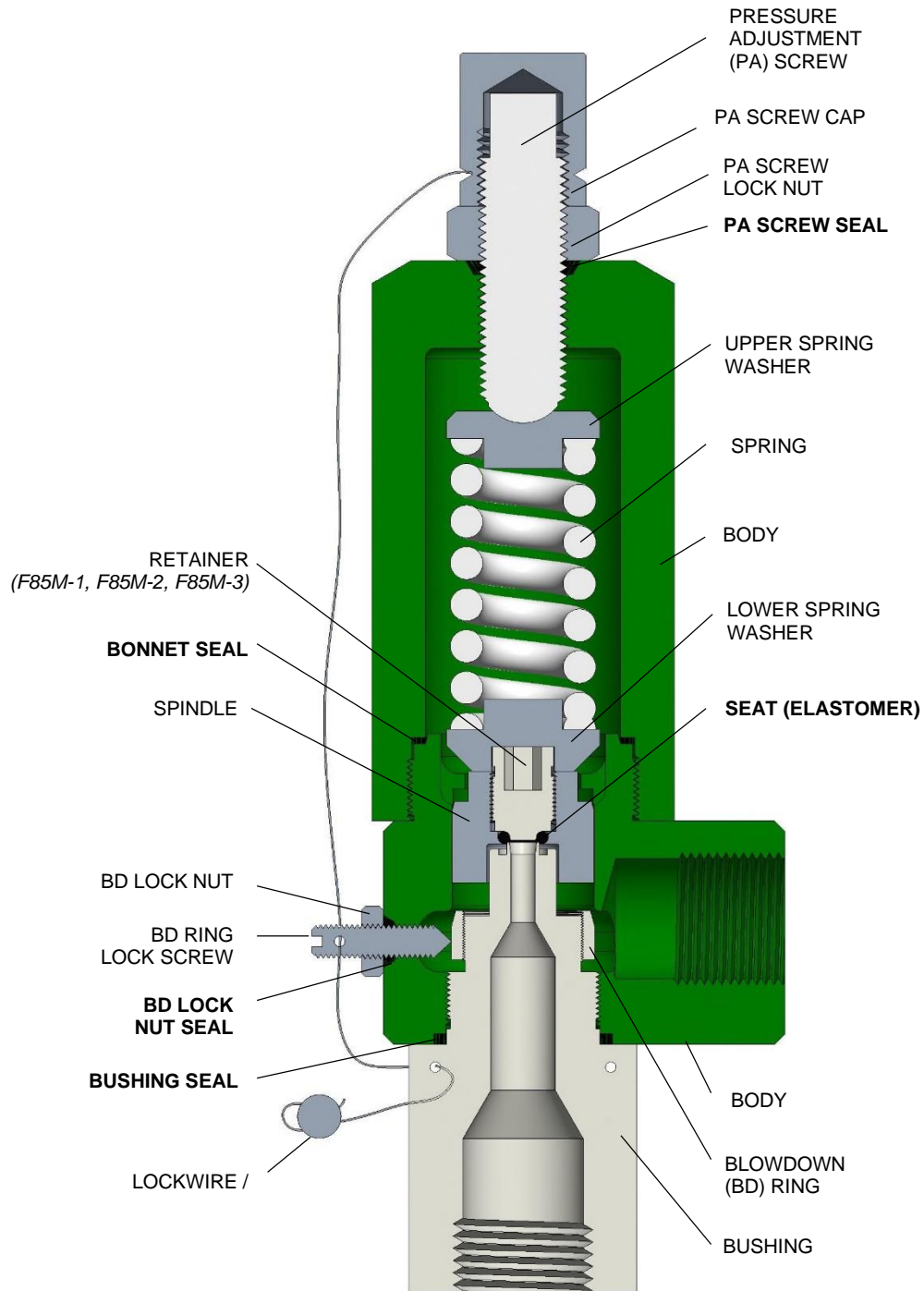

# INSTALLATION, OPERATION, & MAINTENANCE MANUAL



**TITLE:** F80M (F80 'Micro') Series  
Spring-Operated Safety Valve

Rev. K  
Page 19

---

## **Texas Office**

Flow-Safe, Inc.  
16240 Port Northwest Drive  
Houston, TX 77041  
P: (832) 678-2070  
F: (716) 662-2580

## **New York Office**

Flow-Safe, Inc.  
3865 Taylor Road  
Orchard Park, NY 14127  
P: (716) 662-2585  
F: (716) 662-2580

© 2025 Natural Gas Solutions North America, LLC - All rights reserved. Flow Safe reserves the right to make changes in specifications and features shown herein, or discontinue the product described at any time without notice or obligation. Contact your Flow Safe representative for the most current information



[www.flowsafe.com](http://www.flowsafe.com)

F80M Manual DUS.FS.0014  
03.25