

F80 Series

Spring-Operated Safety Valves for Gas Service

Today's industrial needs are being driven by requirements for high-capacity leak-tight pressure relief valves to reduce fugitive emissions and to save customer product.

The F80 Series "High Performance" spring-operated safety valves are engineered to provide superior performance for today's industries.



F80 design features include:

- ASME-UV stamp standard at 15 psig (1.03 barg) and above; 'CE' Mark available for PED or "UKCA" Mark available for PER
- National Board-certified for gas service per ASME Section XIII
- Full lift at set pressure
- Full open until reset
- Adjustable blowdown functionality
- Repeatable, bubble-tight seating and re-seating due to soft seat design
- Superior capacities through large nozzles
- Set pressures to 15,000 psig (1,034 barg)
- -423 to 525 °F (-252 to 274 °C) temperature range
- Standard brass/bronze or 316 SS construction; special materials available
- NPT inlet & outlet standard; flanges, hubs, SAE & AS5202 threads, or other special connections available
- Integral nozzle / inlet bushing
- Packed lift levers available on most sizes

CONTENTS

PAGE

Introduction and Features	1-2
Operation	3
Service Envelope	5
Seat Data	7
Dimensions & Weights	9
F84 Construction	11
F85 Construction	13
Sizing and Capacities	15
Part Numbering	23
How to Order	24
Other Flow Safe Products	25

The policy of FLOW SAFE and its authorized assemblers is a commitment to value through:

- Environmentally compatible products
- Cost-efficient design with minimal parts
- Quality products, readily available
- Flexibility to meet unique customer needs
- “No-hassle” service

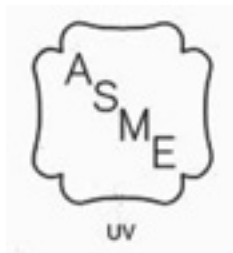

Operation

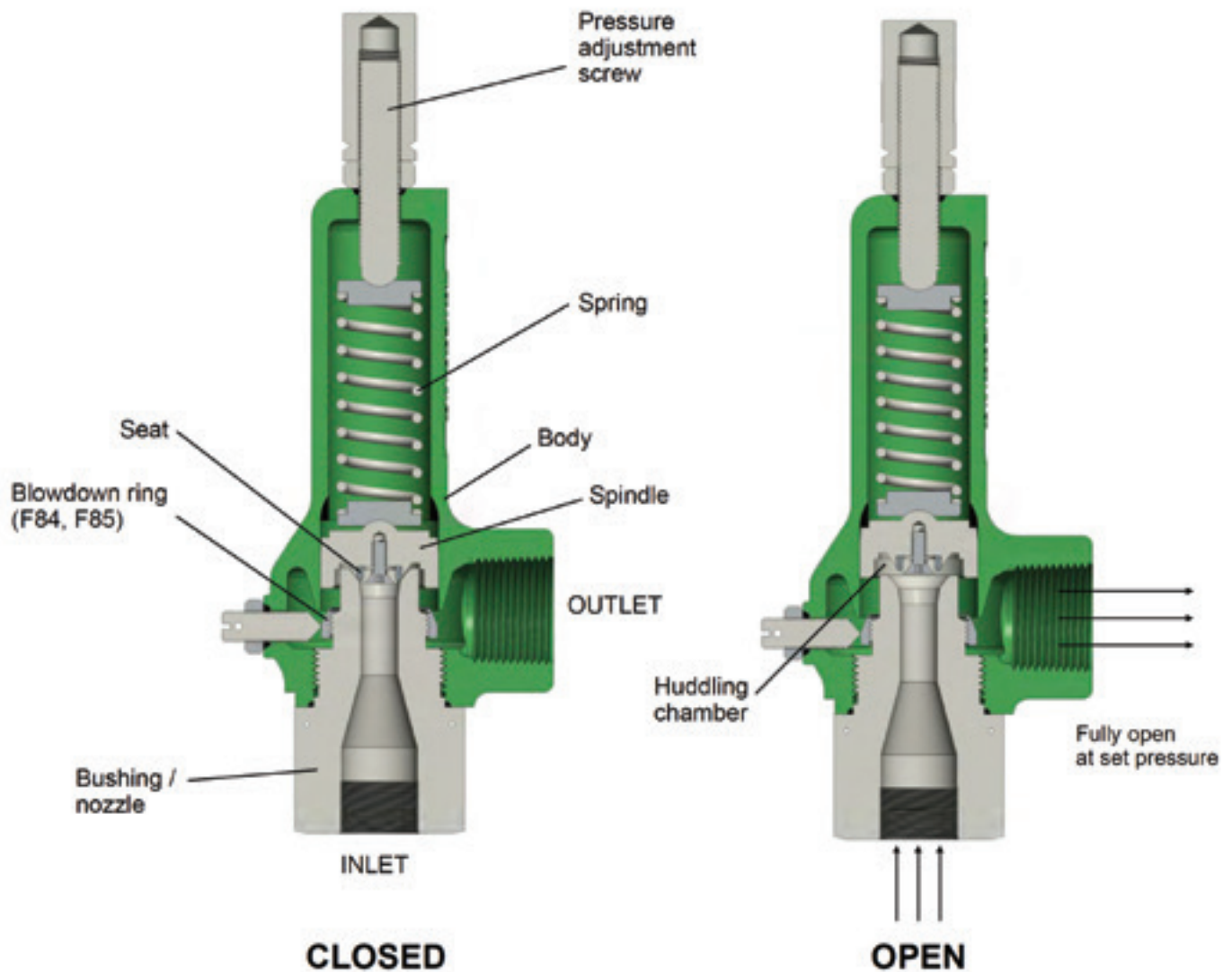

In any pressurized system, there is the potential for a pressure rise that could damage the vessel or piping and create a hazard to people, equipment, or the environment. A pressure relief valve is recognized as the critical safety device that limits this rise by venting excess pressure from the system.

The Flow Safe F80 Series safety valves are high-performance state-of-the-art, cost-efficient, high capacity, soft-seated valves designed to meet the critical needs of today's industry. This series includes Models F84 (plastic seat) and F85 (O-ring seat), with a pressurized spring chamber and unbalanced against backpressure.

Bubble-tight shutoff is achieved through the use of an elastomeric (F85) or plastic (F84) seat. The F80's use a compression spring that opposes system inlet pressure acting on the valve's effective seat area ($F = P \times A$), to establish the set pressure. When system pressure overcomes the spring preload, an initial escape of fluid called "simmer" occurs past the seat. As simmer continues, there is a significant pressure buildup within the huddling chamber that eventually forces the valve to pop open.

Operation (cont'd)

In the F84 and F85, the blowdown ring acts along with the body bore to create a restriction in the flowpath to the valve outlet. Pressure also flows between the spindle and body into the spring chamber or bonnet, to assist the spring to reseat the valve. The tight clearance between these two parts assures that the bonnet cavity pressurization lags the pressure buildup under the spindle, preventing any interference with full lift.



As inlet pressure decays, the net lifting force is reduced to a point where the spindle begins to move downward. Again, the small clearance between the spindle and body guide allows F84/F85 bonnet pressure to increase the closing force on the spindle, resulting in a sharp closing action.

Blowdown, the gap between pop pressure and reseat, in the F84 and F85 is readily controlled by adjusting the blowdown ring. Raising the ring shortens blowdown by helping increase bonnet pressure, while lowering the ring lengthens blowdown. F84's and F85's typically are set at the factory with blowdown from 7 to 10 percent of set pressure, but values up to 20% can be specified.

Superimposed backpressure in the F84 and F85 adds directly to the spring force on the spindle, and has the effect of increasing set pressure by the value of backpressure (e.g., 5 psi of backpressure increases set pressure by 5 psi). These valves are said to be unbalanced against backpressure. They can be set at the factory with appropriate pressure compensation (a 'cold differential test pressure', or CDTP) if superimposed backpressure is specified when ordering. Should a balanced (against the effects of superimposed backpressure) design be needed, customers may be directed to an F88 design.

Flow Safe is proud to offer the F80 Series safety valves to industry. We are confident that these valves present a cost-effective and reliable solution to your needs for overpressure protection.



Service Envelope

Model F84/F85

Orifice Size		-1	-2	-3	-4
Orifice Dia., in (mm)		0.062 (1.57)	0.138 (3.5)	0.209 (5.3)	0.289 (7.3)
Orifice Area, in ² (mm ²)		0.003 (1.9)	0.015 (9.7)	0.034 (21.9)	0.065 (41.9)

Body Type	Body Mtl	Min/ Max	Set Pressure, psig ⁵					
			F84	F85	F84	F85	F84/F85	
M (Micro) – Standard	BR	Min	176 ⁸	15 ⁹	12 ^{1,8}	12 ^{1,9}	12 ¹	12 ¹
		Max	4,072	5,000	4,072	4,072	890	350
	SS	Min	176 ⁸	15 ⁹	12 ^{1,8}	12 ^{1,9}	12 ¹	12 ¹
		Max	4,072	6,600	4,072	4,072	890	350
H (Micro) – HP block ²	BR	Min		5,001			-	-
		Max		6,600			-	-
	SS	Min		6,601			-	-
		Max		10,313			-	-
P (Micro) – 2-piece	SS	Min	4,073		4,073	4,073	-	-
		Max	15,000		15,000	9,944	-	-
Service Temperature Range ^{5,6}	F84	BR	-325 to 406°F (-198 to 208°C)					
		CS	-20 to 525°F (-29 to 274°C)					
		SS	-423 to 525°F (-252 to 274°C)					
	F85	Brass	-65 to 406°F (-54 to 208°C)					
		CS	-20 to 525°F (-29 to 274°C)					
		SS	-65 to 525°F (-54 to 274°C)					

¹Set pressures under 15 psig are non-code and will not receive "UV" stamping.

²The block-style "H" body comes as standard only as shown for the F85M-1, or for instances where MS or SAE outlet threads are required. It may be subbed in at the same pressures shown for the F84M/F85M -2, -3, and -4. Contact factory for more details.

³6,100 psig (420 barg) with ½" or ¾" FNPT inlet.

⁴Flow Safe's -6 is the equivalent to API 526 -D orifice. Flow Safe's -8 is the equivalent to API 526 -E orifice.

⁵Pressure ratings shown are for 100°F and lower and are applicable to metallic components. For higher temperatures, the ratings are subject to change. Contact factory for more details.

⁶See Seat Data for more information on pressure/temperature ratings specific to seat materials.

⁷For pressures above 1,480 psig, use the F84 (plastic seat). For further information, contact factory.

⁸For pressures lower than 600 psig, contact factory.

⁹For pressures lower than 50 psig, contact factory.

Service Envelope (cont'd)

Model F84/F85

Orifice Size		-4	-6 (D) ⁴	-8 (E) ⁴	-F	-G	-H	-J	
Orifice Dia., in (mm)		0.289 (7.3)	0.436 (11.1)	0.577 (14.7)	0.718 (18.2)	0.919 (23.3)	1.149 (29.2)	1.467 (37.3)	
Orifice Area, in ² (mm ²)		0.065 (41.9)	0.149 (96.1)	0.261 (168)	0.405 (261)	0.664 (428)	1.036 (668)	1.689 (1089)	
Body Type	Body Mtl	Min/ Max	Set Pressure, psig ⁵						
			F84/F85						
B Body	BR	Min	15	14 ¹	13 ¹	-	-	-	-
		Max	3,500 ⁷	2,900 ⁷	1,125	-	-	-	-
	SS/ CS	Min	15	14 ¹	13 ¹	-	-	-	-
		Max	4,921 ⁷	2,900 ⁷	1,125	-	-	-	-
C Body Std bolted bonnet	BR	Min	3,501 ⁷	1,515 ⁷	1,126	-	-	-	-
		Max	5,000 ⁷	4,500 ⁷	2,600 ⁷	-	-	-	-
	SS/ CS	Min	2,521 ⁷	1,515 ⁷	1,126	-	-	-	-
		Max	9,612 ⁷	5,774 ^{3,7}	4,292 ⁷	-	-	-	-
D Body Std bolted bonnet	BR	Min	-	-	-	15	15	-	-
		Max	-	-	-	839	668	-	-
	SS/ CS	Min	-	-	-	15	15	-	-
		Max	-	-	-	839	668	-	-
D Body XL bolted bonnet	BR	Min	-	-	-	840	669	-	-
		Max	-	-	-	2,750 ⁷	2,500 ⁷	-	-
	SS/ CS	Min	-	-	-	840	669	-	-
		Max	-	-	-	5,000 ⁷	3,705 ⁷	-	-
E Body Std bolted bonnet	BR	Min	-	-	-	-	-	14 ¹	13 ¹
		Max	-	-	-	-	-	382	298
	SS/ CS	Min	-	-	-	-	-	14 ¹	13 ¹
		Max	-	-	-	-	-	382	298
E Body XL bolted bonnet	BR	Min	-	-	-	-	-	383	299
		Max	-	-	-	-	-	2,000 ⁷	2,000 ⁷
	SS/ CS	Min	-	-	-	-	-	383	299
		Max	-	-	-	-	-	2,750 ⁷	2,700 ⁷
Service Temperature Range ^{5,6}	F84	BR	-325 to 406°F (-198 to 208°C)						
		CS	-20 to 525°F (-29 to 274°C)						
		SS	-423 to 525°F (-252 to 274°C)						
	F85	Brass	-65 to 406°F (-54 to 208°C)						
CS		-20 to 525°F (-29 to 274°C)							
SS		-65 to 525°F (-54 to 274°C)							

¹Set pressures under 15 psig are non-code and will not receive "UV" stamping.

²The block-style "H" body comes as standard only as shown for the F85M-1, or for instances where MS or SAE outlet threads are required. It may be subbed in at the same pressures shown for the F84M/F85M -2, -3, and -4. Contact factory for more details.

³6,100 psig (420 barg) with ½" or ¾" FNPT inlet.

⁴Flow Safe's -6 is the equivalent to API 526 -D orifice. Flow Safe's -8 is the equivalent to API 526 -E orifice.

⁵Pressure ratings shown are for 100°F and lower and are applicable to metallic components. For higher temperatures, the ratings are subject to change. Contact factory for more details.

⁶See Seat Data for more information on pressure/temperature ratings specific to seat materials.

⁷For pressures above 1,480 psig, use the F84 (plastic seat). For further information, contact factory.

⁸For pressures lower than 600 psig, contact factory.

⁹For pressures lower than 50 psig, contact factory.

Seat Data – F84 (Plastic Seat)

Material ³	Set Pressure Range by Orifice, psig				
	-1	-2	-3	-4	-6
PTFE or PCTFE	176 – 1,000 ⁴	176 – 1,000 ⁵	15 – 890 ⁵	15 – 350 ^{1,5} 15 – 2,000 ^{2,5}	15 – 1,500
Polyimide	1,001 – 15,000	1,001 – 15,000	---	2,001 – 9,612 ²	1,501 – 5,774
PEEK	800 – 7,000	600 – 7,000	600 – 890	---	750 – 5,774

Material ³	Set Pressure Range by Orifice, psig				
	-8	-F	-G	-H	-J
PTFE or PCTFE	15 – 1,500	15 – 750	15 – 750	15 – 750	15 – 750
Polyimide	1,501 – 4,292	751 – 5,000	751 – 3,705	751 – 2,750	751 – 2,700
PEEK	750 – 4,292	500 – 5,000	500 – 3,705	300 – 2,750	150 – 2,700

¹Applicable to -4 Micro body

²Applicable to -4 B or C body

³Material selection is contingent on compatibility with application media.

⁴For set pressures under 600 psig, contact factory.

⁵For set pressures under 50 psig, contact factory.

Material	Continuous Process Temperature, °F (°C) ²	Trade Names/Brands Offered ¹
PTFE or PCTFE	-423 to 400 (-252 to 204)	Teflon®, Ekonol-Filled Teflon, Kel-F.
Polyimide	-423 to 500 (-252 to 260)	VespeI®, Duratron®, or equal
Polyetheretherketone	0 to 525 (-18 to 274)	PEEK

¹Other materials may be considered at the discretion of Flow Safe Engineering. Contact factory.

²Ranges may differ by exact grade.

Seat Data – F85 (O-Ring Seat)

Material ⁴	Set Pressure Range by Orifice, psig ³				
	-1	-2	-3	-4	-6
Nitrile	15 – 1,480	15 – 1,480	15 – 890	15 – 350 ¹ 15 – 1,480 ²	15 – 1,480
Fluoroelastomer					
Ethylene Propylene					
FFKM (Perfluoroelastomer)					
Polyurethane	15 – 10,313	15 – 9,944	750 – 890	N/A ¹ 750 – 4,500 ²	500 – 1,480 ⁵

Material ⁴	Set Pressure Range by Orifice, psig ³				
	-8	-F	-G	-H	-J
Nitrile	15 – 1,480	15 – 1,480	15 – 1,480	15 – 1,480	15 – 1,480
Fluoroelastomer					
Ethylene Propylene					
FFKM (Perfluoroelastomer)					
Polyurethane	500 – 1,480 ⁵	500 – 1,480 ⁵	200 – 1,480 ⁵	150 – 1,480 ⁵	100 – 1,480 ⁵

¹Applicable to -4 Micro body

²Applicable to -4 B or C body

³Ranges differ by exact elastomer grade and durometer.

⁴Material selection is contingent on compatibility with application media.

⁵For pressures above 1,480 psig, contact factory.

Material	Continuous Process Temperature, °F (°C) ²	Trade Names/Brands Offered ¹
Nitrile	-30 – 275 (-34 – 135)	Buna-N
Fluoroelastomer	-30 – 400 (-34 – 204)	Viton [®] or equal
Ethylene Propylene	-65 – 325 (-54 – 163)	EPR/EPDM
FFKM (Perfluoroelastomer)	-22 – 621 (-18 – 274)	Chemraz [®] , Kalrez [®] , Perlast [®] , or equivalent
Polyurethane	-65 – 225 (-54 – 107)	Polyurethane

¹Other materials may be considered at the discretion of Flow Safe Engineering. Contact factory

²Ranges may differ by exact grade and durometer.

Dimensions & Weights

Threaded Connections

Model	Orifice Size	Body Size	Weight ¹ , lb (kg)	Standard Connections ²		Dimensions, in (mm) ¹		
				Inlet	Outlet	A	B	C ³
F84M / F85M	-1, -2, 3, -4	M -Standard	1.7 (0.8)	1/2", 3/4" MNPT ⁴	1/2", 3/4" FNPT	2.93 (74)	1.30 (33)	6.7 (170)
F84M / F85M	-1, -2, -3, -4	M-HP block	3.2 (1.5)	3/4" M/P coned & threaded	1/2", 3/4" FNPT	2.00 (51)	1.50 (38)	6.0 (152)
F84M / F85M	-1, -2	M -2-piece	2.9 (1.3)	1/2", 3/4" MNPT	1/2", 3/4" FNPT	2.93 (74)	1.50 (38)	8.4 (213)
F84 / F85	-4, -6, -8	B	5.3 (2.4)	3/4", 1" FNPT ⁴ 3/4", 1" MNPT	1" FNPT 1" FNPT	2.65 (67) 3.20 (81)	2.07 (53) 2.07 (53)	9.9 (251) LL - 11.3 (287) 10.4 (264) LL - 11.8 (300)
F84 / F85	-4, -6, -8	C	12.9 (5.9)	3/4", 1" FNPT ⁴	1" FNPT	2.65 (67)	2.07 (53)	13.1 (333) LL - 14.5 (368)
F84 / F85	-F, -G	D -Standard	32 (15)	1-1/2" FNPT	2" FNPT	2.60 (66)	3.15 (80)	14.4 (366) LL - 17.0 (432)
F84 / F85	-F, -G	D -XL	41 (19)	1-1/2" FNPT	2" FNPT	2.60 (66)	3.15 (80)	17.8 (452) LL - 20.4 (518)
F84 / F85	-H, -J	E -Standard	46 (21)	2" FNPT ⁴	3" FNPT	2.72 (69)	4.25 (108)	14.8 (376) LL - 17.4 (442)
F84 / F85	-H, -J	E -XL	70 (32)	2" FNPT ⁴	3" FNPT	2.72 (69)	4.25 (108)	22.0 (559) LL - 24.6 (625)

¹Dimensions are typical and subject to change without notice. Contact Flow Safe for submittal drawing whenever specific dimensions are needed for construction.

²Other connection sizes and types are available, including SAE or MS / A55202 thread bosses. "Coned & threaded" connection accepts Butech, Autoclave, or equivalent male tubing, collar, and gland.

³LL = Dimension with lift lever

⁴F84M/F85M-1 and -2 are available with 1/4" inlet; F84/F85-4 and F84/F85-6 are available with 1/2" female inlet; F84/F85-H is available with 1-1/2" inlet.

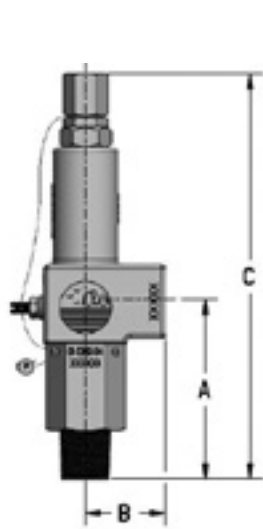

M (Micro) Body

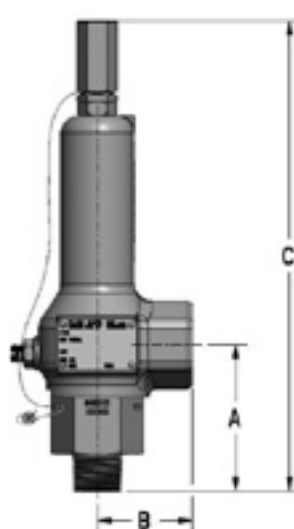

B Body

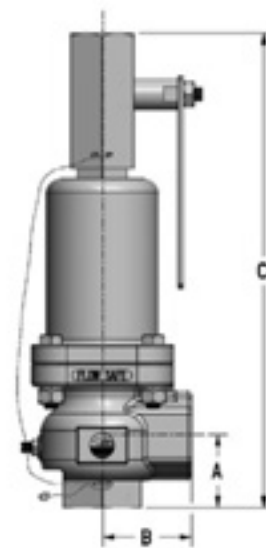

C, D, E Body - Bolted Bonnet
(Lift lever shown)

Dimensions & Weights

Flanged Connections

Model	Orifice	Body Size	Weight ¹ , lb (kg)	Standard Connections ²		Dimensions, in (mm) ¹		
				Inlet	Outlet	A	B	C ³
F84M / F85M	-1, -2, -3, -4	M – Std		(Contact Factory)				
		M – HP Block						
		M – 2-piece						
F84 / F85	-4, -6, -8	B	22 (10)	1" 150#	1" 150#	4.72 (120)	4.75 (121)	11.9 (302)
				1" 300#				LL – 13.3 (338)
				1" 600#				
	-4, -6, -8	C	29 (13)	1" 900#	1" 300#	5.72 (145)	6.75 (171)	12.9 (328)
				1" 1500#				LL – 14.3 (363)
				1" 2500#				
	-F, -G	D – Std Bonnet	54 (24)	1-1/2" 150#	2" 150#	4.87 (124)	4.75 (121)	16.6 (422)
				1-1/2" 300#				LL – 19.2 (488)
				1-1/2" 600#				16.6 (422)
		D – XL Bonnet	62 (28)	1-1/2" 900#	2" 300#	5.25 (133)	5.06 (129)	20.0 (508)
				1-1/2" 1500#				LL – 22.6 (574)
								20.4 (518)
-H, -J	E – Std Bonnet	87 (39)	2" 150#	3" 150#	5.37 (137)	6.50 (165)	17.5 (445)	
			2" 300#				LL – 20.0 (508)	
	2" 600#	24.7 (628)						
E – XL Bonnet	105 (48)	2" 900#	3" 300#	6.56 (167)	7.0 (178)	25.9 (658)		
		2" 1500#				LL – 28.4 (721)		

¹Dimensions are typical and subject to change without notice. Weights are approximate and include maximum flange ratings. Flange facing must be specified (RF, RTJ, or other). Contact Flow Safe for submittal drawing whenever specific dimensions are needed for construction. API 526 dimensions are available on request for applicable orifice and connection sizes.

²Other sizes and welded connection types are available, including Grayloc hubs and Swagelok VCR. Contact factory for details.

³LL = Dimension with lift lever

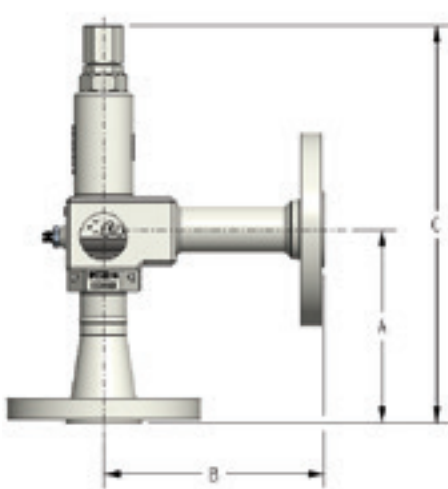

M (Micro) Body

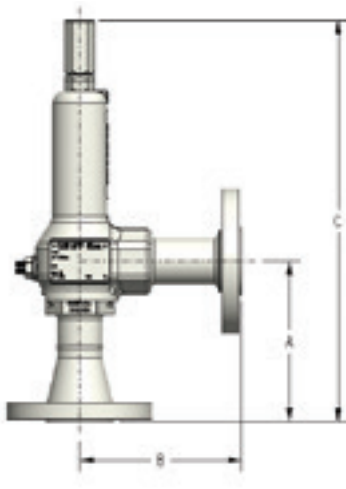

B Body

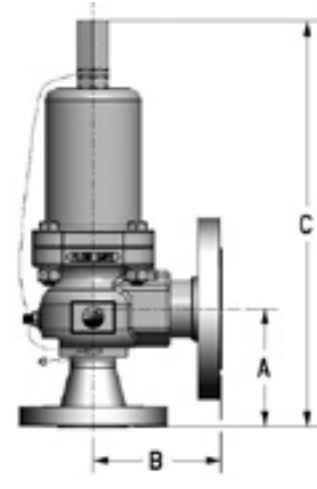

C, D, E Body - Bolted Bonnet
(Lift lever shown)

F84 Construction

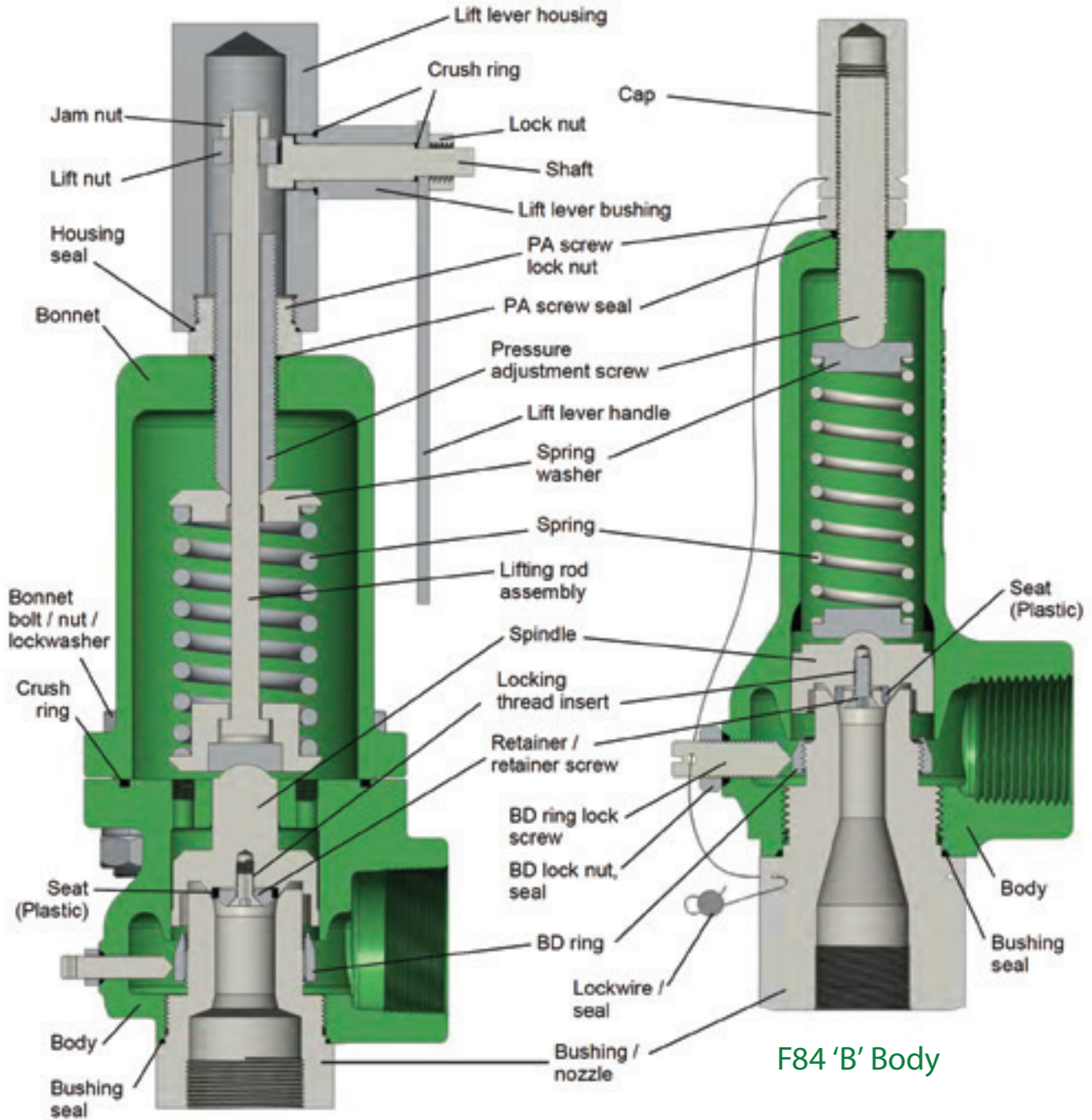

F84 'C' / 'D' / 'E' Body with Lift Lever

F84 'B' Body

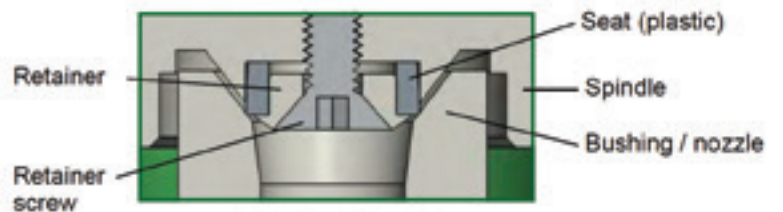

F84 Seat Detail

See p. 9-10 for dimensions and weights.

F84 Construction

F84 Part Name	Standard Materials of Construction ¹		
	Bronze/Brass	Carbon Steel (NACE)	Stainless Steel (NACE)
Body - standard / Micro block	SB-61 C92200 / B16	SA-351 CF8M	SA-351 CF8M
Body - Micro 2-piece	—	SA-479 316/316L	SA-479 316/316L
Bonnet	SA-351 CF8M	SA-216 WCB	SA-351 CF8M
Spring	A313 302/304 or 17-7	A401 chromium-silicon (Inconel X750 or Elgiloy)	A313 302/304 or 17-7 (Inconel X750 or Elgiloy)
Spring washer	B16 C36000	CS / plated (316 SS) 6061	A479 316/316L
Cap	6061 Aluminum	Aluminum	6061 Aluminum
Pressure adjustment screw	B16 C36000	Carbon steel / plated A479	A479 316/316L
Blowdown (BD) ring	B16 C36000	316/316L	A479 316/316L
BD ring lock screw	Monel	316 SS	316 SS
Lock nuts, jam nuts, lift nut	316 SS	316 SS	316 SS
Bonnet bolt	SA-193 Gr. B8 Cl. 1 or 2	SA-193 Gr. B8 Cl. 1 or 2	SA-193 Gr. B8 Cl. 1 or 2
Nut	SA-194 Gr. 8	SA-194 Gr. 8	SA-194 Gr. 8
Lockwasher	316 SS	316 SS	316 SS
Bushing / nozzle	B16 C36000 H02	SA-479 316/316L	SA-479 316/316L
Spindle	B16 C36000	A479 316/316L	A479 316/316L
Seat	Plastic ²	Plastic ²	Plastic ²
Retainer	B16 C36000	A479 316/316L	A479 316/316L
Retainer screw	Monel or brass	316 SS	316 SS
Locking thread insert	304 SS	304 SS (Inconel X750)	304 SS (Inconel X750)
Crush rings, seals	Teflon / PTFE	Teflon / PTFE	Teflon / PTFE
Lockwire	18-8 SS	18-8 SS	18-8 SS
Seal	Lead	Lead	Lead
Lifting rod assembly ³	316 SS	316 SS	316 SS
Lift lever housing, bushing ³	SA-479 316/316L	SA-479 316/316L	SA-479 316/316L
Shaft ³	17-4 SS	17-4 SS	17-4 SS
Lift lever handle ³	316 SS	316 SS	316 SS

¹Materials are subject to change without notice. Contact Flow Safe for availability of materials not shown. Contact Flow Safe for availability of materials or material configurations not shown. See Part Numbering for more options. NACE trim is in accordance with NACE MR0175 / ISO 15156.

²See "Seat Data" on p. 7 for selections.

³Lift levers are available on all valve body sizes except 'Micro'.

F84M 'M' (Micro) Body - 2-Piece

F84M-1 w/ coned & threaded inlet shown



F84M 'M' (Micro) Body - Standard

F84M-4 w/ NPT connections shown

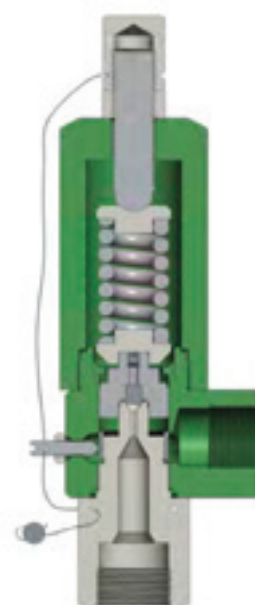

F85 Construction

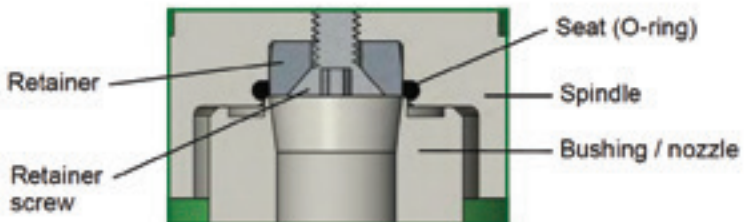
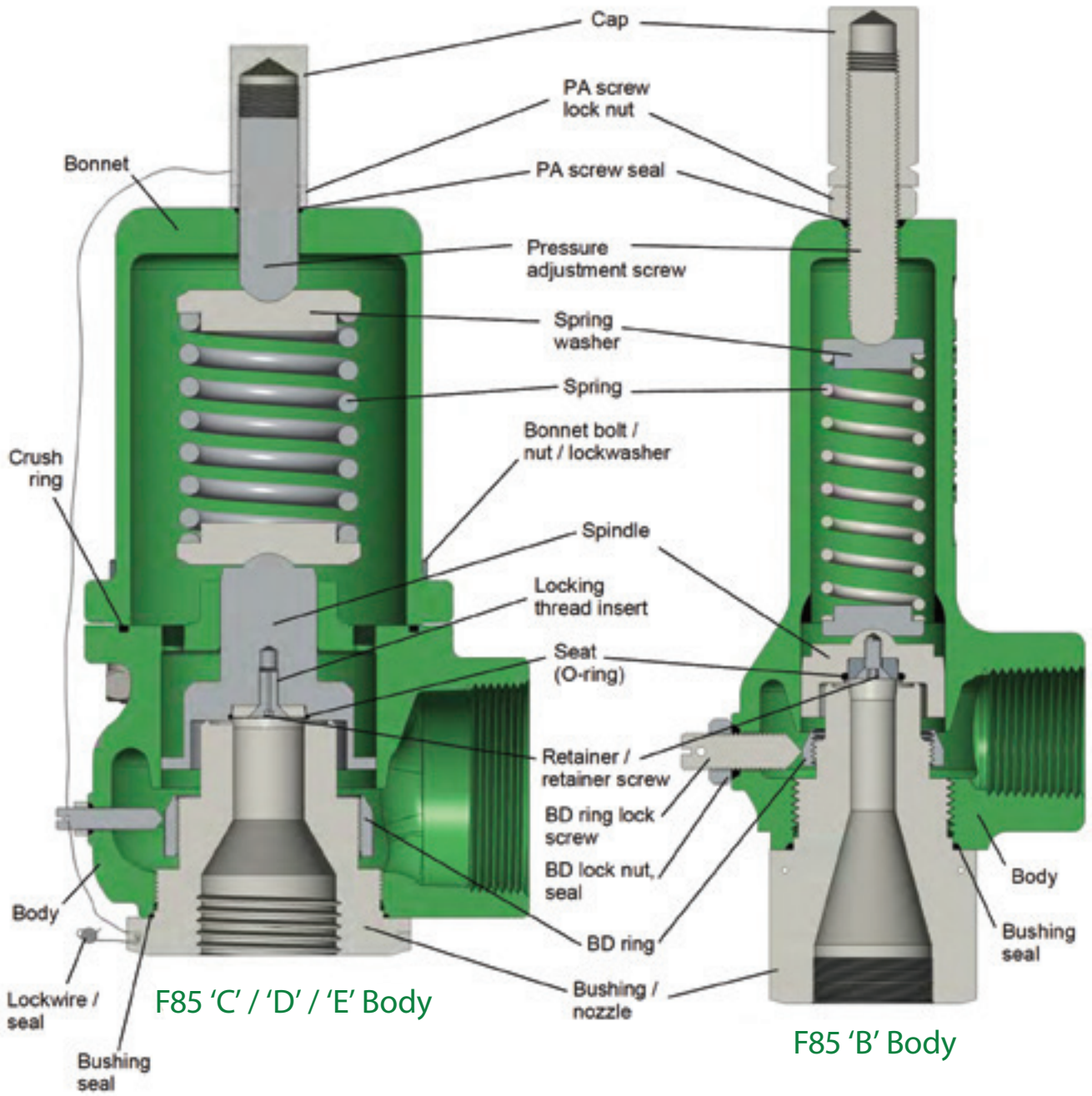

F85 Seat Detail

See p. 9-10 for dimensions and weights.

F85 Construction

F85 Part Name	Standard Materials of Construction ^{1,3}		
	Bronze/Brass	Carbon Steel (NACE)	Stainless Steel (NACE)
Body - standard / Micro block	SB-61 C92200 / B16	SA-351 CF8M	SA-351 CF8M
Body - Micro 2-piece	—	SA-479 316/316L	SA-479 316/316L
Bonnet	SA-351 CF8M	SA-216 WCB	SA-351 CF8M
Spring	A313 302/304 or 17-7	A401 chromium-silicon (Inconel X750 or Elgiloy)	A313 302/304 or 17-7 (Inconel X750 or Elgiloy)
Spring washer	B16 C36000	CS / plated (316 SS) 6061	A479 316/316L
Cap	6061 Aluminum	Aluminum	6061 Aluminum
Pressure adjustment screw	B16 C36000	Carbon steel / plated A479	A479 316/316L
Blowdown (BD) ring	B16 C36000	316/316L	A479 316/316L
BD ring lock screw	Monel	316 SS	316 SS
Lock nuts, jam nuts, lift nut	316 SS	316 SS	316 SS
Bonnet bolt	SA-193 Gr. B8 Cl. 1 or 2	SA-193 Gr. B8 Cl. 1 or 2	SA-193 Gr. B8 Cl. 1 or 2
Nut	SA-194 Gr. 8	SA-194 Gr. 8	SA-194 Gr. 8
Lockwasher	316 SS	316 SS	316 SS
Bushing / nozzle	B16 C36000 H02	SA-479 316/316L	SA-479 316/316L
Spindle	B16 C36000	A479 316/316L	A479 316/316L
Seat	Elastomer ²	Elastomer ²	Elastomer ²
Retainer	B16 C36000	A479 316/316L	A479 316/316L
Retainer screw	Monel or brass	316 SS	316 SS
Locking thread insert	304 SS	304 SS (Inconel X750)	304 SS (Inconel X750)
Crush rings, seals	Teflon / PTFE	Teflon / PTFE	Teflon / PTFE
Lockwire	18-8 SS	18-8 SS	18-8 SS
Seal	Lead	Lead	Lead

¹Materials are subject to change without notice. Contact Flow Safe for availability of materials not shown. Contact Flow Safe for availability of materials or material configurations not shown. See Part Numbering for more options. NACE trim is in accordance with NACE MR0175 / ISO 15156.

²See "Seat Data" on p. 8 for selections.

³Lift levers are available on all valve body sizes except 'Micro'. Lift lever construction is as shown on p. 11.

**F85M 'M' (Micro)
Body - HP Block**
F85M-4 w/ SAE AS5202
connections shown

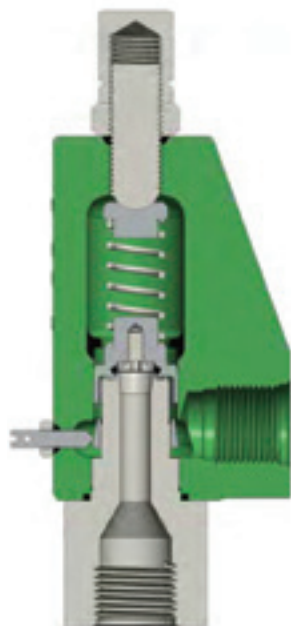

**F85M 'M' (Micro)
Body - Standard**
F85M-3 w/ NPT
connections shown

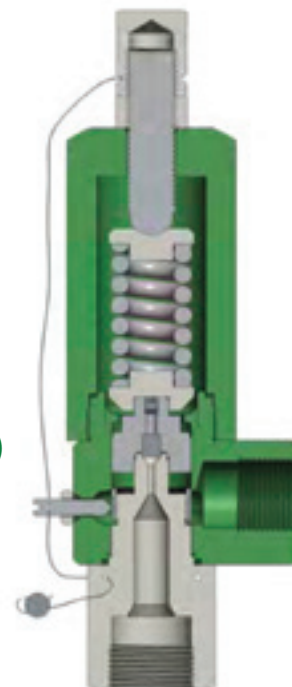

Sizing

Sizing for Gas & Vapor Service

The ASME Boiler & Pressure Vessel Code, Section VIII, requires that capacity certification be obtained for pressure relief valves designed for gas or vapor service. Certification tests include determination of the rated coefficient of discharge for the PRVs at an overpressure of 10% or 3 psi, whichever is greater.

To size the F80 series relief valve for gas or vapor service, the following information is required:

- Required flow capacity
- Required set pressure
- Backpressure (pressure at valve outlet)
- Acceptable overpressure [10% or 3 psi max for unfired case per ASME VIII-1, UG-153(a); 21% for fire case per ASME VIII-1, UG-153(a)(2)]
- Operating pressure, to assure that it is below valve reseal pressure
- Gas properties, including molecular weight, specific heat ratio or gas constant, and compressibility factor

To select the required orifice size for a gas or vapor application, the below equations should be used. Depending on the gas, critical flow generally exists at pressures above 11 to 12 psig with zero backpressure, or at higher pressures where backpressure is less than approximately 50% of inlet pressure. If backpressure is less than or equal to P_{cf} in the following equation, critical flow will occur:

$$P_{cf} = P_1 \left[\frac{2}{k+1} \right]^{\frac{k}{k-1}}$$

Critical Flow

In US customary units:

$$A = \frac{V\sqrt{MTZ}}{6.32CK_dP_1K_bK_c}$$

- OR -

$$A = \frac{W}{CK_dP_1K_bK_c} \sqrt{\frac{TZ}{M}}$$

In SI units:

$$A = \frac{2.676V\sqrt{MTZ}}{CK_dP_1K_bK_c}$$

- OR -

$$A = \frac{W}{CK_dP_1K_bK_c} \sqrt{\frac{TZ}{M}}$$

Subcritical Flow

In US customary units:

$$A = \frac{V}{4645F_2K_dK_c} \sqrt{\frac{MTZ}{P_1(P_1-P_2)}}$$

- OR -

$$A = \frac{W}{735F_2K_dK_c} \sqrt{\frac{TZ}{MP_1(P_1-P_2)}}$$

In SI units:

$$A = \frac{47.95V}{F_2K_dK_c} \sqrt{\frac{MTZ}{P_1(P_1-P_2)}}$$

- OR -

$$A = \frac{17.9W}{F_2K_dK_c} \sqrt{\frac{TZ}{MP_1(P_1-P_2)}}$$

- A = Required discharge orifice area, in² or mm²
- V = Required flow rate, scfm or Nm³/min
- W = Required flow rate, lb/hr or kg/hr
- K_d = Rated ASME discharge coefficient (see p. 19-22)
- C = Gas constant, dependent on specific heat ratio $k = C_p/C_v$ (See table on p. 16)
- P₁ = Relieving pressure (set pressure plus overpressure plus atmospheric pressure), psia or kPaa
- P₂ = Backpressure, psia or kPaa
- K_b = Backpressure correction factor, for balanced bellows valves only (otherwise, use 1.0)
- K_c = Rupture disk correction factor:
1.0 with no disk
0.9 with disk in combination
- M = Molecular weight at inlet relieving conditions (See table on p. 17)
- T = Relieving temperature, °R (°F + 460) or °K (°C + 273)
- Z = Compressibility factor at inlet relieving conditions, 1.0 if unknown
- F₂ = Coefficient of subcritical flow; See figure on p. 17
- k = Specific heat ratio, C_p/C_v (See table on p.16)
- P_{cf} = Critical flow nozzle pressure, psia or kPaa

See p. 18 for sizing example.

Sizing

Sizing for Gas & Vapor Service (cont'd)

Values of Coefficient C

(For equations on p. 15)

k	C		k	C		k	C		k	C	
	USC	SI		USC	SI		USC	SI		USC	SI
1.00	315	0.0239	1.26	343	0.0261	1.51	365	0.0277	1.76	384	0.0292
1.01	317	0.0240	1.27	344	0.0261	1.52	366	0.0278	1.77	385	0.0292
1.02	318	0.0241	1.28	345	0.0262	1.53	367	0.0279	1.78	386	0.0293
1.03	319	0.0242	1.29	346	0.0263	1.54	368	0.0279	1.79	386	0.0293
1.04	320	0.0243	1.30	347	0.0263	1.55	369	0.0280	1.80	387	0.0294
1.05	321	0.0244	1.31	348	0.0264	1.56	369	0.0280	1.81	388	0.0294
1.06	322	0.0245	1.32	349	0.0265	1.57	370	0.0281	1.82	389	0.0295
1.07	323	0.0246	1.33	350	0.0266	1.58	371	0.0282	1.83	389	0.0296
1.08	325	0.0246	1.34	351	0.0266	1.59	372	0.0282	1.84	390	0.0296
1.09	326	0.0247	1.35	352	0.0267	1.60	373	0.0283	1.85	391	0.0297
1.10	327	0.0248	1.36	353	0.0268	1.61	373	0.0283	1.86	391	0.0297
1.11	328	0.0249	1.37	353	0.0268	1.62	374	0.0284	1.87	392	0.0298
1.12	329	0.0250	1.38	354	0.0269	1.63	375	0.0285	1.88	393	0.0298
1.13	330	0.0251	1.39	355	0.0270	1.64	376	0.0285	1.89	393	0.0299
1.14	331	0.0251	1.40	356	0.0270	1.65	376	0.0286	1.90	394	0.0299
1.15	332	0.0252	1.41	357	0.0271	1.66	377	0.0286	1.91	395	0.0300
1.16	333	0.0253	1.42	358	0.0272	1.67	378	0.0287	1.92	395	0.0300
1.17	334	0.0254	1.43	359	0.0272	1.68	379	0.0287	1.93	396	0.0301
1.18	335	0.0254	1.44	360	0.0273	1.69	379	0.0288	1.94	397	0.0301
1.19	336	0.0255	1.45	360	0.0274	1.70	380	0.0289	1.95	397	0.0302
1.20	337	0.0256	1.46	361	0.0274	1.71	381	0.0289	1.96	398	0.0302
1.21	338	0.0257	1.47	362	0.0275	1.72	382	0.0290	1.97	398	0.0302
1.22	339	0.0258	1.48	363	0.0276	1.73	382	0.0290	1.98	399	0.0303
1.23	340	0.0258	1.49	364	0.0276	1.74	383	0.0291	1.99	400	0.0303
1.24	341	0.0259	1.50	365	0.0277	1.75	384	0.0291	2.00	400	0.0304
1.25	342	0.0260	—	—	—	—	—	—	—	—	—

Sizing

Sizing for Gas & Vapor Service (cont'd)

Common Gas Properties

Gas	Molecular Weight	Specific Heat Ratio, k (Cp/Cv)	Gas	Molecular Weight	Specific Heat Ratio, k (Cp/Cv)
Acetylene	26	1.28	Hydrogen Sulfide	34	1.32
Air	29	1.40	Isobutane	58	1.10
Ammonia	17	1.30	Isopentane	72	1.08
Argon	40	1.66	Methane	16	1.31
Benzene	78	1.12	Methyl Chloride	50	1.20
n-Butane	58	1.09	Natural Gas	19	1.27
Carbon Dioxide	44	1.29	Nitrogen	28	1.40
Chlorine	71	1.36	Oxygen	32	1.40
Ethane	30	1.19	n-Pentane	72	1.08
Ethylene	28	1.24	Propane	44	1.13
Helium	4	1.66	Propylene	42	1.15
n-Hexane	86	1.06	Sulfur Dioxide	64	1.27
Hydrogen	2	1.41	Water vapor / steam ¹	18	1.33

¹For water vapor / steam service, if the relieving conditions are confirmed to be steam and are within pressure/temperature limits of the F80 series, Flow Safe can offer the F80 but it cannot be "UV" stamped as a code valve. Contact factory for more details.

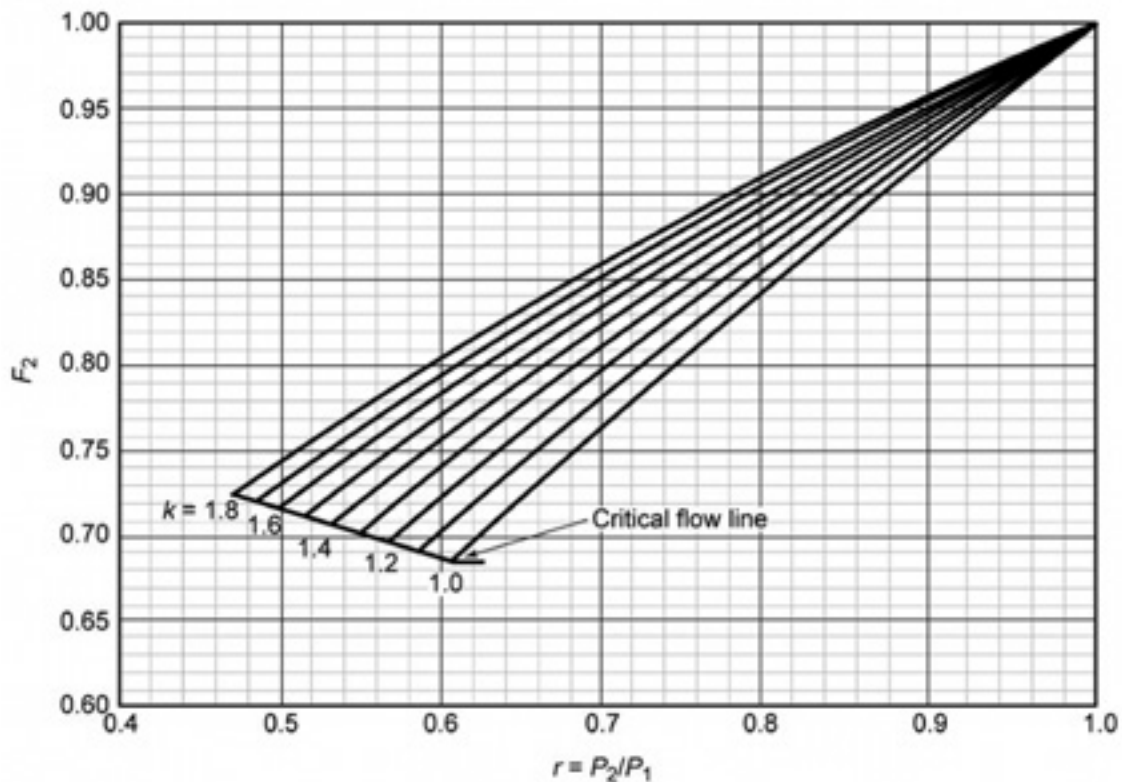

Values of F2 for Subcritical Flow

(For equations on p. 15)

Sizing

Sizing for Gas & Vapor Service (cont'd)

Gas Sizing Example

Service conditions: Set pressure = 1200 psig; 10% overpressure; 60 psig backpressure
Natural gas at 120 °F; Compressibility factor = 0.95
Capacity required = 22,000 scfm

Assume Model F84/F85 and associated discharge coefficient (see top of p. 5-6)

Check critical flow pressure:

$$P_{cf} = P_1 \left[\frac{2}{k+1} \right]^{\frac{k}{k-1}}$$
$$P_{cf} = [(1200)(1.10)+14.7] \cdot \left[\frac{2}{1.27+1} \right]^{\frac{1.27}{1.27-1}} = 736 \text{ psia}$$

Backpressure is less than P_{cf} , so critical flow will occur.

Choose critical flow equation from p. 15 that uses "scfm" for flow units:

$$A = \frac{V \sqrt{MTZ}}{6.32CK_D P_1 K_B K_C}$$
$$A = \frac{22,000 \sqrt{19*(460 + 120)*0.95}}{6.32*344*0.878*1334.7*1*1}$$
$$A = 0.884 \text{ in}^2$$

Select F84/F85 with "H" orifice (1.036 in²) from orifice size listing in table on p. 5-6.

Based on inlet pressure and temperature, the XL bolted bonnet will be required in carbon or stainless steel.

Sizing for Liquid to Gas Flashing Flow

In the case of single-phase liquid to gas flashing flow (i.e. liquid hydrogen flashing to gaseous hydrogen during a relieving event), Flow Safe sizes, tests, and marks these valves for gas service. This is not to be confused with two-phase flow; see the F88 product catalog for more details.

Sizing / Capacities

F84 / F85 Flow Capacities: $K_d = 0.878$
 10% / 3 psi Overpressure, 0 BP, 60°F, Z=1.0, MW=29

Air

Orifice Size:	-1	-2	-3	-4	-6	-8	-F	-G	-H	-J
Orifice Area, in ² (mm ²):	0.003 (1.9)	0.015 (9.7)	0.034 (21.9)	0.065 (41.9)	0.149 (96.1)	0.261 (168)	0.405 (261)	0.664 (428)	1.036 (668)	1.689 (1089)
Set Pressure, psig	SCFM	SCFM	SCFM	SCFM	SCFM	SCFM	SCFM	SCFM	SCFM	SCFM
15	1.6	7.9	18	34	78	137	213	349	545	888
25	2.1	10	23	45	102	179	278	456	712	1160
50	3.4	17	38	73	167	293	454	744	1162	1894
75	4.7	23	53	102	233	408	633	1038	1620	2641
100	6.0	30	68	130	299	524	812	1332	2078	3388
150	8.7	43	98	188	431	754	1171	1919	2995	4882
200	11	57	128	245	563	985	1529	2507	3911	6377
250	14	70	158	303	694	1216	1887	3094	4828	7871
300	17	83	189	360	826	1447	2246	3682	5745	9366
350	19	96	219	418	958	1678	2604	4269	6661	10860
400	22	110	249	475	1090	1909	2962	4857	7578	12354
450	25	123	279	533	1222	2140	3321	5444	8494	13849
500	27	136	309	590	1354	2371	3679	6032	9411	15343
600	33	163	369	705	1617	2833	4396	7207	11244	18332
700	38	189	429	820	1881	3295	5112	8382	13077	21320
800	43	216	489	936	2144	3756	5829	9557	14911	24309
900	48	242	543 ¹	1051	2408	4218	6546	10732	16744	27298
1000	54	269		1166	2672	4680	7262	11907	18577	30286
1500	80	402		1741	3990	6989	10846	17781	27743	45230
2000	107	534		2316	5308	9299	14429	23656	36909	60174
2500	133	667		2891	6627	11608	18012	29531	46075	75117
3000	160	800		3466	7945	13917	21595	35406	50658 ¹	81094 ¹
3500	187	933		4041	9263	16226	25179	41280		
4000	213	1065		4616	10582	18535	28762	43689 ¹		
4500	240	1198		5191	11900	19884 ¹	32345			
5000	266	1331		5766	13218		35928			
6000	319	1596		6916	15259 ¹					
7000	372	1862		8067						
8000	425	2127		9217						
9000	478	2392		10367						
10000	532	2658		11071 ¹						
11000	585	2923								
12000	638	3189								
13000	691	3454								
14000	744	3720								
15000	797	3985								

¹Capacity calculations performed at maximum pressure values of 890 psig for -3, 9612 psig for -4, 5774 psig for -6, 4292 psig for -8, 3705 psig for -G, 2750 psig for -H, and 2700 for -J

Sizing / Capacities

F84 / F85 Flow Capacities: $K_d = 0.878$
 10% / 3 psi Overpressure, 0 BP, 60°F, Z=1.0, MW=19

Natural Gas

Orifice Size:	-1	-2	-3	-4	-6	-8	-F	-G	-H	-J
Orifice Area, in ² (mm ²):	0.003 (1.9)	0.015 (9.7)	0.034 (21.9)	0.065 (41.9)	0.149 (96.1)	0.261 (168)	0.405 (261)	0.664 (428)	1.036 (668)	1.689 (1089)
Set Pressure, psig	SCFM	SCFM	SCFM	SCFM	SCFM	SCFM	SCFM	SCFM	SCFM	SCFM
15	1.9	9.4	21	41	94	164	254	417	651	1061
25	2.5	12	28	53	122	214	332	544	850	1385
50	4.0	20	46	87	199	349	542	889	1387	2261
75	5.6	28	63	121	278	487	756	1239	1934	3153
100	7.2	36	81	156	357	625	970	1590	2481	4045
150	10.4	52	117	224	514	901	1398	2291	3575	5829
200	14	68	153	293	672	1176	1825	2993	4669	7613
250	17	83	189	362	829	1452	2253	3694	5764	9397
300	20	99	225	430	986	1728	2681	4395	6858	11181
350	23	115	261	499	1144	2003	3109	5097	7952	12964
400	26	131	297	568	1301	2279	3536	5798	9046	14748
450	29	147	333	636	1458	2555	3964	6499	10141	16532
500	33	163	369	705	1616	2830	4392	7201	11235	18316
600	39	194	441	842	1931	3382	5248	8603	13423	21884
700	45	226	512	980	2245	3933	6103	10006	15612	25452
800	52	258	584	1117	2560	4484	6959	11409	17800	29020
900	58	289	649 ¹	1254	2875	5036	7814	12811	19989	32588
1000	64	321		1391	3190	5587	8670	14214	22177	36156
1500	96	480		2078	4763	8344	12947	21227	33120	53995
2000	128	638		2765	6337	11101	17225	28241	44062	71835
2500	159	796		3451	7911	13857	21503	35254	55005	89675
3000	191	955		4138	9485	16614	25780	42267	60476 ¹	96810 ¹
3500	223	1113		4824	11058	19371	30058	49281		
4000	254	1272		5511	12632	22128	34336	52156 ¹		
4500	286	1430		6197	14206	23737 ¹	38614			
5000	318	1589		6884	15780		42891			
6000	381	1905		8257	18216 ¹					
7000	444	2222		9630						
8000	508	2539		11003						
9000	571	2856		12376						
10000	635	3173		13216 ¹						
11000	698	3490								
12000	761	3807								
13000	825	4123								
14000	888	4440								
15000	951	4757								

¹Capacity calculations performed at maximum pressure values of 890 psig for -3, 9612 psig for -4, 5774 psig for -6, 4292 psig for -8, 3705 psig for -G, 2750 psig for -H, and 2700 for -J

Sizing / Capacities

F84 / F85 Flow Capacities: $K_d = 0.878$
 10% / 3 psi Overpressure, 0 BP, 60°F, Z=1.0, MW=2

Hydrogen

Orifice Size:	-1	-2	-3	-4	-6	-8	-F	-G	-H	-J
Orifice Area, in ² (mm ²):	0.003 (1.9)	0.015 (9.7)	0.034 (21.9)	0.065 (41.9)	0.149 (96.1)	0.261 (168)	0.405 (261)	0.664 (428)	1.036 (668)	1.689 (1089)
Set Pressure, psig	SCFM	SCFM	SCFM	SCFM	SCFM	SCFM	SCFM	SCFM	SCFM	SCFM
15	6.0	30.1	68	131	299	524	814	1334	2081	3393
25	7.9	39	89	170	391	685	1062	1742	2717	4430
50	12.8	64	146	278	638	1117	1734	2843	4436	7231
75	17.9	90	203	388	890	1558	2418	3965	6186	10085
100	23.0	115	260	498	1141	1999	3102	5086	7936	12938
150	33.1	166	375	718	1645	2881	4471	7330	11436	18644
200	43	216	490	937	2148	3763	5839	9573	14936	24350
250	53	267	605	1157	2652	4645	7207	11816	18436	30057
300	64	318	720	1376	3155	5526	8575	14060	21936	35763
350	74	368	835	1596	3658	6408	9944	16303	25436	41469
400	84	419	950	1816	4162	7290	11312	18546	28937	47176
450	94	470	1065	2035	4665	8172	12680	20790	32437	52882
500	104	520	1179	2255	5169	9054	14049	23033	35937	58588
600	124	622	1409	2694	6175	10817	16785	27520	42937	70001
700	145	723	1639	3133	7182	12581	19522	32006	49937	81414
800	165	824	1869	3572	8189	14344	22258	36493	56938	92826
900	185	926	2075 ¹	4012	9196	16108	24995	40980	63938	104239
1000	205	1027		4451	10203	17872	27732	45466	70938	115651
1500	307	1534		6647	15237	26689	41415	67900	105940	172714
2000	408	2041		8843	20270	35507	55098	90333	140941	229778
2500	509	2547		11039	25304	44325	68781	112766	175943	286841
3000	611	3054		13235	30338	53143	82464	135200	193443 ¹	309666 ¹
3500	712	3561		15431	35372	61961	96147	157633		
4000	814	4068		17627	40406	70779	109830	166831 ¹		
4500	915	4575		19823	45440	79291 ¹	123513			
5000	1016	5081		22019	50474		137196			
6000	1219	6095		26411	58267 ¹					
7000	1422	7108		30803						
8000	1624	8122		35195						
9000	1827	9136		39587						
10000	2030	10149		42275 ¹						
11000	2233	11163								
12000	2435	12176								
13000	2638	13190								
14000	2841	14203								
15000	3043	15217								

¹Capacity calculations performed at maximum pressure values of 890 psig for -3, 9612 psig for -4, 5774 psig for -6, 4292 psig for -8, 3705 psig for -G, 2750 psig for -H, and 2700 for -J

Sizing / Capacities

F84 / F85 Flow Capacities: $K_d = 0.878$
 10% / 3 psi Overpressure, 0 BP, 60°F, Z=1.0, MW=32

Oxygen

Orifice Size:	-1	-2	-3	-4	-6	-8	-F	-G	-H	-J
Orifice Area, in ² (mm ²):	0.003 (1.9)	0.015 (9.7)	0.034 (21.9)	0.065 (41.9)	0.149 (96.1)	0.261 (168)	0.405 (261)	0.664 (428)	1.036 (668)	1.689 (1089)
Set Pressure, psig	SCFM	SCFM	SCFM	SCFM	SCFM	SCFM	SCFM	SCFM	SCFM	SCFM
15	1.5	7.5	17	33	75	131	203	333	520	848
25	2.0	10	22	43	98	171	266	435	679	1108
50	3.2	16	36	70	159	279	434	711	1109	1808
75	4.5	22	51	97	222	390	605	991	1546	2521
100	5.7	29	65	124	285	500	776	1272	1984	3234
150	8.3	41	94	179	411	720	1118	1832	2859	4661
200	11	54	123	234	537	941	1460	2393	3734	6088
250	13	67	151	289	663	1161	1802	2954	4609	7514
300	16	79	180	344	789	1382	2144	3515	5484	8941
350	18	92	209	399	915	1602	2486	4076	6359	10367
400	21	105	237	454	1040	1823	2828	4637	7234	11794
450	23	117	266	509	1166	2043	3170	5197	8109	13220
500	26	130	295	564	1292	2263	3512	5758	8984	14647
600	31	155	352	673	1544	2704	4196	6880	10734	17500
700	36	181	410	783	1796	3145	4880	8002	12484	20353
800	41	206	467	893	2047	3586	5565	9123	14234	23207
900	46	231	519 ¹	1003	2299	4027	6249	10245	15985	26060
1000	51	257		1113	2551	4468	6933	11367	17735	28913
1500	77	383		1662	3809	6672	10354	16975	26485	43179
2000	102	510		2211	5068	8877	13774	22583	35235	57444
2500	127	637		2760	6326	11081	17195	28192	43986	71710
3000	153	764		3309	7585	13286	20616	33800	48361 ¹	77416 ¹
3500	178	890		3858	8843	15490	24037	39408		
4000	203	1017		4407	10102	17695	27457	41708 ¹		
4500	229	1144		4956	11360	18982 ¹	30878			
5000	254	1270		5505	12619		34299			
6000	305	1524		6603	14567 ¹					
7000	355	1777		7701						
8000	406	2030		8799						
9000	457	2284		9897						
10000	507	2537		10569 ¹						
11000	558	2791								
12000	609	3044								
13000	659	3297								
14000	710	3551								
15000	761	3804								

¹Capacity calculations performed at maximum pressure values of 890 psig for -3, 9612 psig for -4, 5774 psig for -6, 4292 psig for -8, 3705 psig for -G, 2750 psig for -H, and 2700 for -J

Part Numbering

S 8 5 J E - 0 2 R F 2 - 0 3 R F 1 - C S - S S - V T N

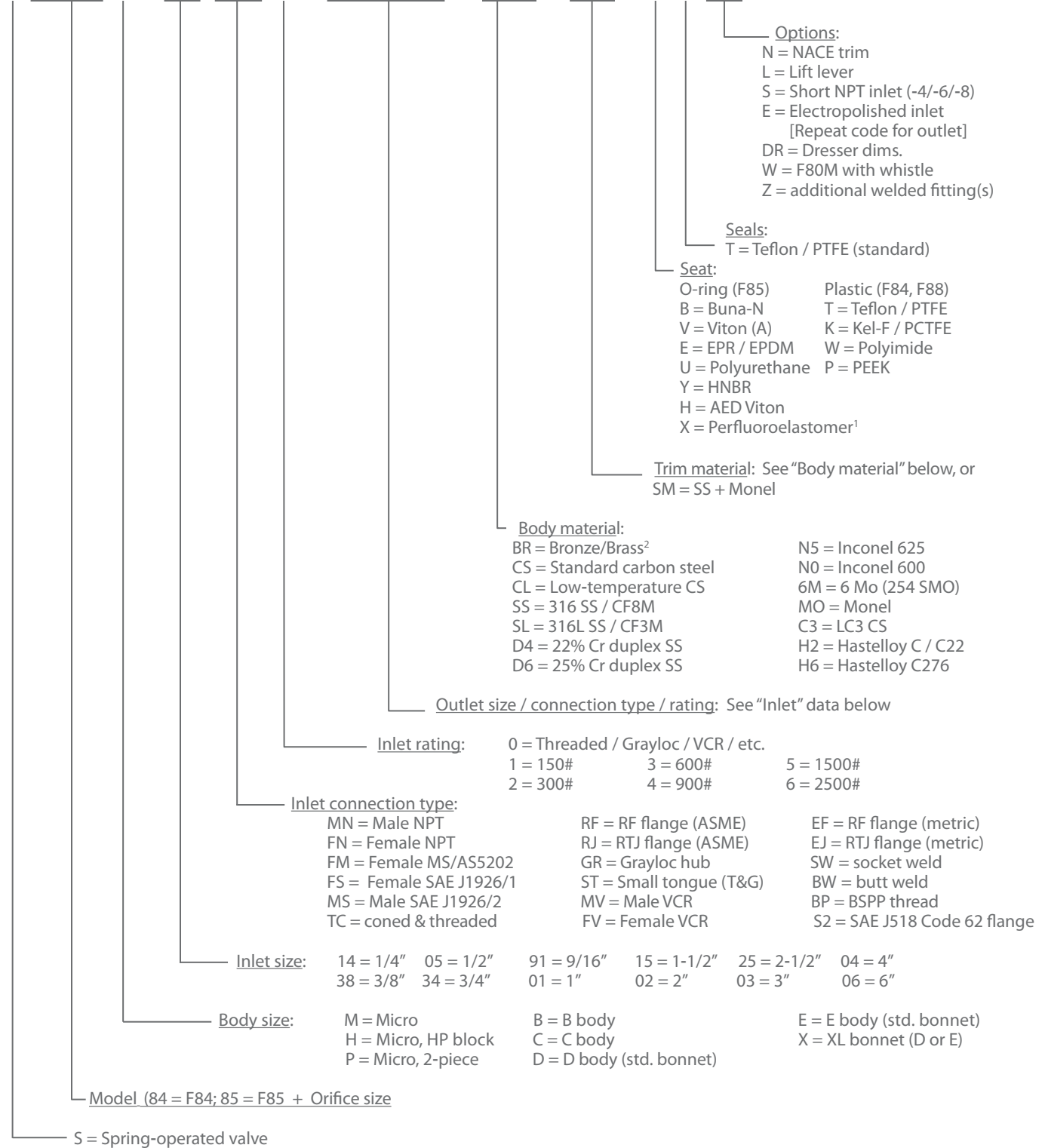

¹If not specified, Kalrez (Code Z), Chemraz (C), Perlast (M), or similar grade will be used.

²When used for body material, BR indicates bronze. When used for trim material, BR indicates brass.

How to Order

Sample Specification Sheet

Please include data as shown in the following table when contacting Flow Safe or their representatives regarding a relief valve application:

Service Conditions	
Quantity	each
Valve identification / tag number(s)	
Delivery time	weeks
Service media / fluid state	
Molecular weight (gases)	
Compressibility factor (gases)	
Specific heat ratio (gases)	
Specific gravity (liquids)	
Viscosity (liquids)	
Required capacity	scfm (Nm ³ /hr) lb/hr (kg/hr) gpm (lpm)
Set pressure	psig barg kPag
Allowable overpressure	% or psi / bar / kPa
Backpressure	psig barg kPag
Required blowdown	% or psi / bar / kPa
Relieving temperature (at relief valve location)	°F or °C
Normal operating temperature (at relief valve location)	°F or °C
System design temperature	°F or °C
Required cleanliness level	
Valve Selection	
Body / bonnet material	
Trim (wetted internals) material	
Seat and seal material	
Size and ASME Class for inlet / outlet	
Flange facing, inlet/outlet	
Special inlet / outlet	
Orifice area calculated / selected	
Valve part number (optional - see p. 22)	

Experts in Soft-Seated Technology

Other Flow Safe Products



F7000/8000 Series

Pilot-Operated Relief Valve - ASME XIII



F84L/88 Series

Liquid Relief Valve (F84L) and Liquid/
Gas Relief Valve (F88) - ASME XIII



F70U Series

Unloader Valve



F9000 Series

Liquid Surge Relief



F70PR

Pilot-Operated R Series Relief Valve - DOT

Leaders in "true" High Performance with commitment to value through:

- 24/7 service, repair, and support
- Soft seats offering unsurpassed tightness
- Large coefficients and orifice areas = Best capacities
- Backpressure-balanced without bellows
- ASME Sec. XIII, API, DOT, ISO 9001, CE (PED), UKCA (PER), Marine class societies (e.g., ABS, BV), KGS
- Trained representatives with solid factory support

Texas Office

Flow Safe, Inc.
16240 Port Northwest Drive
Houston, TX 77041
P: (832) 678-2070
F: (716) 662-2580

New York Office

Flow Safe, Inc.
3865 Taylor Road
Orchard Park, NY, USA 14127
P: (716) 662-2585
F: (716) 662-2580

© 2024 Flow Safe, Inc. - All rights reserved. Flow Safe reserves the right to make changes in specifications and features shown herein, or discontinue the product described at any time without notice or obligation. Contact your Flow Safe representative for the most current information.



www.dresserutility.com