



**F9000 SERIES
SURGE RELIEF VALVE (LIQUID)**



**INSTALLATION,
OPERATION, & MAINTENANCE MANUAL**

Revision: D
Date of Issue: Oct. 6, 2021

Approved by: jwo
Engineering Projects Dir.

 GG
Sr. Design Eng.

TABLE OF CONTENTS

<u>Topic</u>	<u>Page</u>
1.0 General.....	3
2.0 Description, Operation, Service Envelope, Installation, & Startup	
2.1 Description / Operation	4
2.2 Service Envelope	5
2.3 Storage and Handling	5
2.4 Installation.....	6
2.5 Startup	7
3.0 Main Valve Maintenance	
3.1 Disassembly of the F9000 Series Main Valve.....	7
3.2 Reassembly of the F9000 Series Main Valve	9
4.0 Set Pressure Adjustment and Main Valve Testing	
4.1 Set Pressure Adjustment	10
4.2 Testing of the Main Valve Subassembly.....	10
5.0 Troubleshooting Guide	11
6.0 Softgoods Kits.....	12

INSTALLATION, OPERATION, & MAINTENANCE MANUAL



TITLE: F9000 Series
Surge Relief Valve

Rev. D
Page 3 of 12

1.0 GENERAL

- 1) This manual is intended to provide users with direction and guidance for the maintenance of FLOW SAFE F9000 Series surge relief valves. This manual indicates the proper method of valve disassembly, soft goods replacement, and valve reassembly. FLOW SAFE provides this manual as a guideline and reference only. It is not intended to serve as a training manual or manufacturing guide. FLOW SAFE assumes no responsibility for personal or property damage that may occur in conjunction with this manual.
- 2) FLOW SAFE recommends that all valves be placed on a regular maintenance schedule that includes the routine replacement of softgoods. FLOW SAFE recommends softgoods replacement every three years but cautions that each customer make their own determination and set their own schedule based upon use and environment. FLOW SAFE believes that when maintenance and reassembly is performed as outlined in this manual there is no safety hazard.

Cycling the valve at least once a year is considered to be good practice to verify operation.
- 3) When a new valve leaves FLOW SAFE, it has been manufactured and tested by trained and experienced personnel. When you remove a valve from your system and perform the maintenance tasks that are outlined herein you will need proper training.

Do **not** attempt to accomplish these tasks without adequate training and understanding of the valve operation.
- 4) Any and all stated or implied warranties that are in effect during the purchase of a new FLOW SAFE valve are null and void once the valve has been disassembled by someone other than approved FLOW SAFE personnel.
- 5) It is highly recommended that all instructions herein be read in full prior to any assembly, disassembly, or operation of this equipment.
- 6) The noted manufacturer's standard lubricants should be used only if compatible with process fluid and application.
- 7) Specific design details described in this document are subject to change without notice.
- 8) Should the need arise for general assistance, contact the FLOW SAFE Sales department at (716) 662-2585 or (800) 828-1036. For more detailed technical assistance, contact the FLOW SAFE Engineering department at (716) 662-2585.

2.0 DESCRIPTION, OPERATION, SERVICE ENVELOPE, INSTALLATION, and STARTUP

2.1 DESCRIPTION / OPERATION

FLOW SAFE F9000 Series surge relief valves are a variation of the F7000 pilot-operated valve series and are intended for liquid systems. Operating without a pilot, the surge relief valve provides rapid opening of the main piston in the event of an overpressure condition at the inlet. A trapped volume of gas in the “dome” (space above the piston) provides a steady downward force to seat the piston until the moment that set pressure is reached. This gas volume then compresses slightly to allow piston movement upward to full lift as dictated by continued inlet pressure increases and the need for more relief capacity. Full lift occurs by approximately 30 – 40% overpressure. The piston closes when inlet pressure decreases to the set point.

Dome gas pressure is maintained by an external air or nitrogen source connected to the dome through a self-relieving regulator provided with the valve. The regulator compensates for ambient temperature changes that would otherwise affect dome gas pressure and, consequently, valve set pressure. Other than maintaining dome pressure, the regulator is independent of main valve opening and closing functions. Proper dome gas pressure is determined based on the area ratio between the piston seal and seat, and is a function of valve size; values are indicated in Section 4.1 of this manual.

The F9000 uses an elastomeric seat on the piston to achieve tight shut-off. An O-ring piston seal prevents leakage from the dome to the outlet. Wear rings on the piston eliminate metal-to-metal contact with the liner and help to provide smooth and consistent operation.

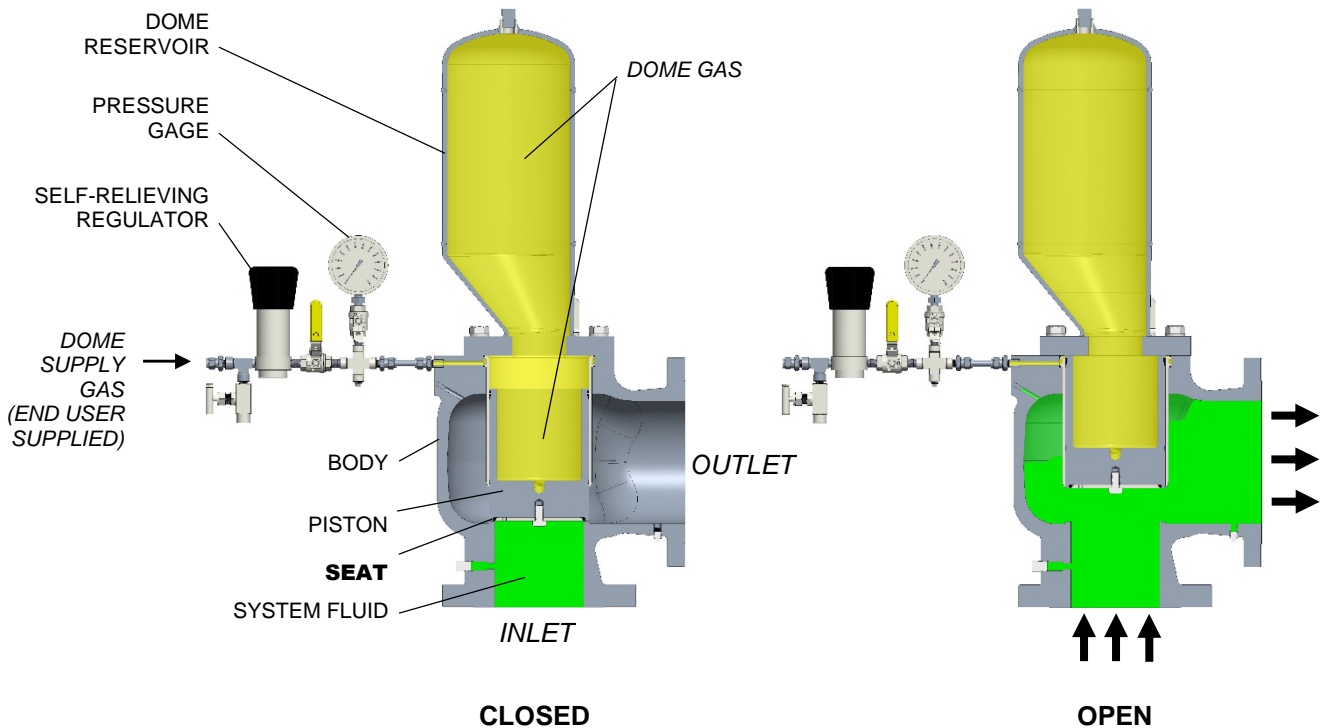

INSTALLATION, OPERATION, & MAINTENANCE MANUAL



TITLE: F9000 Series
Surge Relief Valve

Rev. D
Page 5 of 12

2.2 SERVICE ENVELOPE

SEAT MATERIAL	Temperature, °F (°C)		Pressure, psig (barg)	
	MIN. ¹	MAX.	MIN.	MAX. ³
Buna-N	-30 (-34) ²	275 (135)	5 (0.34)	³
Fluorocarbon: Viton ® or equal	-30 (-34)	400 (204)	5 (0.34)	³
Ethylene propylene (EPR/EPDM)	-65 (-54)	325 (163)	5 (0.34)	³
Perfluoroelastomer: Kalrez ®, Chemraz ®, or equal	0 (-18)	525 (274)	5 (0.34)	³
Polyurethane	-60 (-54)	225 (107)	5 (0.34)	³

¹ Confirm service / application with factory.

² -65 (-54) with low temp nitrile

³ Maximum pressure depends on application and available regulators; contact Flow Safe

2.3 STORAGE AND HANDLING

A. STORAGE

Prior to installation, Flow Safe pressure relief valve assemblies and parts should be stored in a clean, dry environment if possible. Inlet and outlet connections should remain covered until the item is ready for installation.

For outside storage, protection from the elements is recommended particularly if plugs and flange covers are not weather-tight. Exposed carbon steel surfaces should remain coated with a suitable rust inhibitor until the assembly is ready for installation.

Even though elastomers and lubricants in the relief valve typically have a long shelf life and can be used in environments down to -40 °F/°C, operability of the main piston should be checked before placing the valve in service after extended storage. See Section 2.4.

B. HANDLING AND LIFTING

Flange facings and other gasket sealing surfaces shall be isolated from contact with other hard objects through the use of cardboard or other soft materials. Placing flanged surfaces directly on wooden skids should be avoided due to possible contact with nails.

Valve assemblies shall be lifted only from installed lifting lugs or brackets, provided on all valves 2" x 3" and larger or with heavy flanges or accessories. Smaller valves can be carried by hand (by holding the main body and not tubing or other fittings). When two lifting lugs are provided, generally on valve assemblies 4" x 6" and larger, the load must be balanced by use of a sling (chain, web, or rope). See diagram below. All hooks, slings, and other lifting devices shall be rated for the valve assembly weight as identified by project drawings, shipping documents, or scales used at receiving. Slings may be wrapped around an installed dome reservoir in order to engage the lifting brackets.

TYPICAL LIFTING ARRANGEMENT
*LIFTING BRACKETS
ROTATED 60-90° IN THIS VIEW*

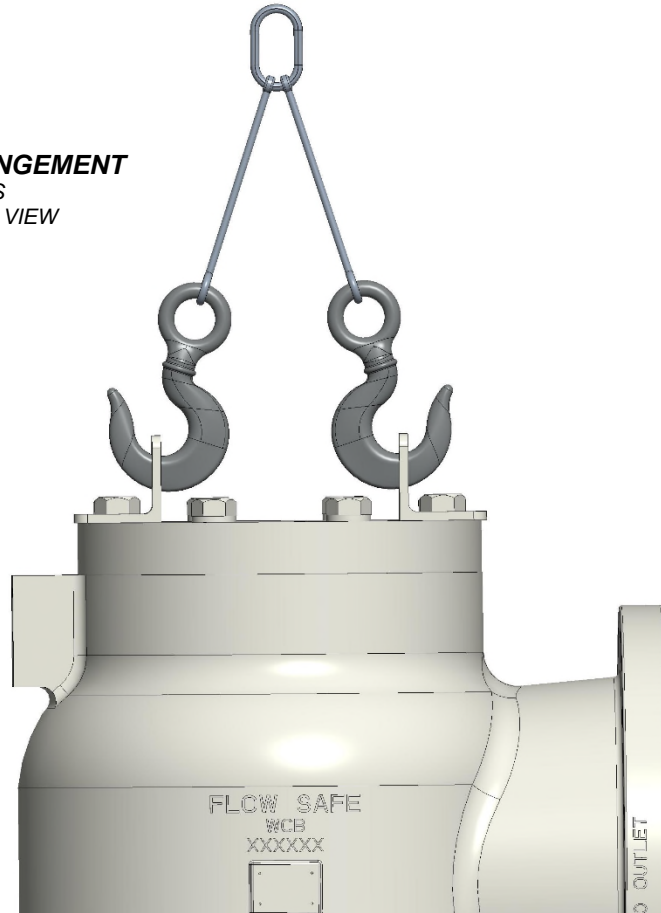

2.4 INSTALLATION

CAUTION: Use lifting brackets provided on the cap for lifting the entire valve assembly. The dome reservoir may be rigged around its base only for removal of the cap during maintenance.

NOTE: The F9000 is supplied with the dome chamber evacuated, following tests for pressure integrity at Flow Safe. The user must provide dome gas per the instructions below.

If the valve has been in storage for a significant length of time, verify that the main piston can still freely move by pushing on it manually through the valve inlet. If it does not return to the closed position, it may be necessary to seat the piston using a pressure source connected to the dome reservoir.

The F9000 Series surge relief valve should be installed in the upright position in accordance with accepted piping practices.

Verify set pressure according to system requirements. After connection of the external gas source, charge the dome with a pressure value corresponding to set pressure in accordance with Section 4.1. Adjustment of the regulator may be required.

If a block valve is used below the relief valve, it should be opened before pressurizing the system. This block valve should be locked open during normal system operation.

2.5 STARTUP

Pressure can be applied to the valve as system pressure increases, or by slowly opening the block valve (if there is one) after the system has attained operating pressure. The piston should stay seated as long as operating pressure remains below set pressure. Verify that the valve seat is leak-tight, in accordance with Section 4.2.

The valve is now ready for service. Inspection and maintenance should be performed on a regular basis, typically once a year, depending on the service conditions.

3.0 MAIN VALVE MAINTENANCE

3.1 DISASSEMBLY OF THE F9000 SERIES MAIN VALVE

(See Illustration on Page 7)

CAUTION: Do not attempt to disassemble any valve while it remains in service with incoming line pressure.

CAUTION: Relieve or isolate system inlet pressure before bleeding off dome pressure. Removing dome pressure first will open the valve if the inlet is pressurized.

- 1) Remove the valve from service, or safely block the incoming pressure before disassembling the valve and performing maintenance.
- 2) If necessary, remove the regulator and other connected components.
- 3) Unbolt the connected dome reservoir and supports, if supplied. Remove the bolts, lockwashers, and any lifting brackets that hold the valve cap in place.
- 4) With the cap (and integral dome reservoir assembly, if supplied) removed, remove the top liner seal.
- 5) Carefully reach into the valve and remove the piston assembly. Newer pistons may have an interior threaded hole in which a cap bolt can be inserted to use for lifting. Note that the liner may come out with the piston assembly. Care must be taken during this removal because any damage might result in a sealing problem after the valve is reassembled.
- 6) The liner may then be removed; again, care must be taken not to damage the liner. Do not attempt to pry or force the liner out as you may score the surface and cause a sealing problem.
- 7) Remove the retainer bolt and seat retainer.
- 8) Replace softgoods in the piston and liner per the instructions in Section 3.2. Replacement soft goods are listed in Section 6.0 of this manual.

**F9000 SERIES MAIN VALVE
ASSEMBLY ILLUSTRATION**

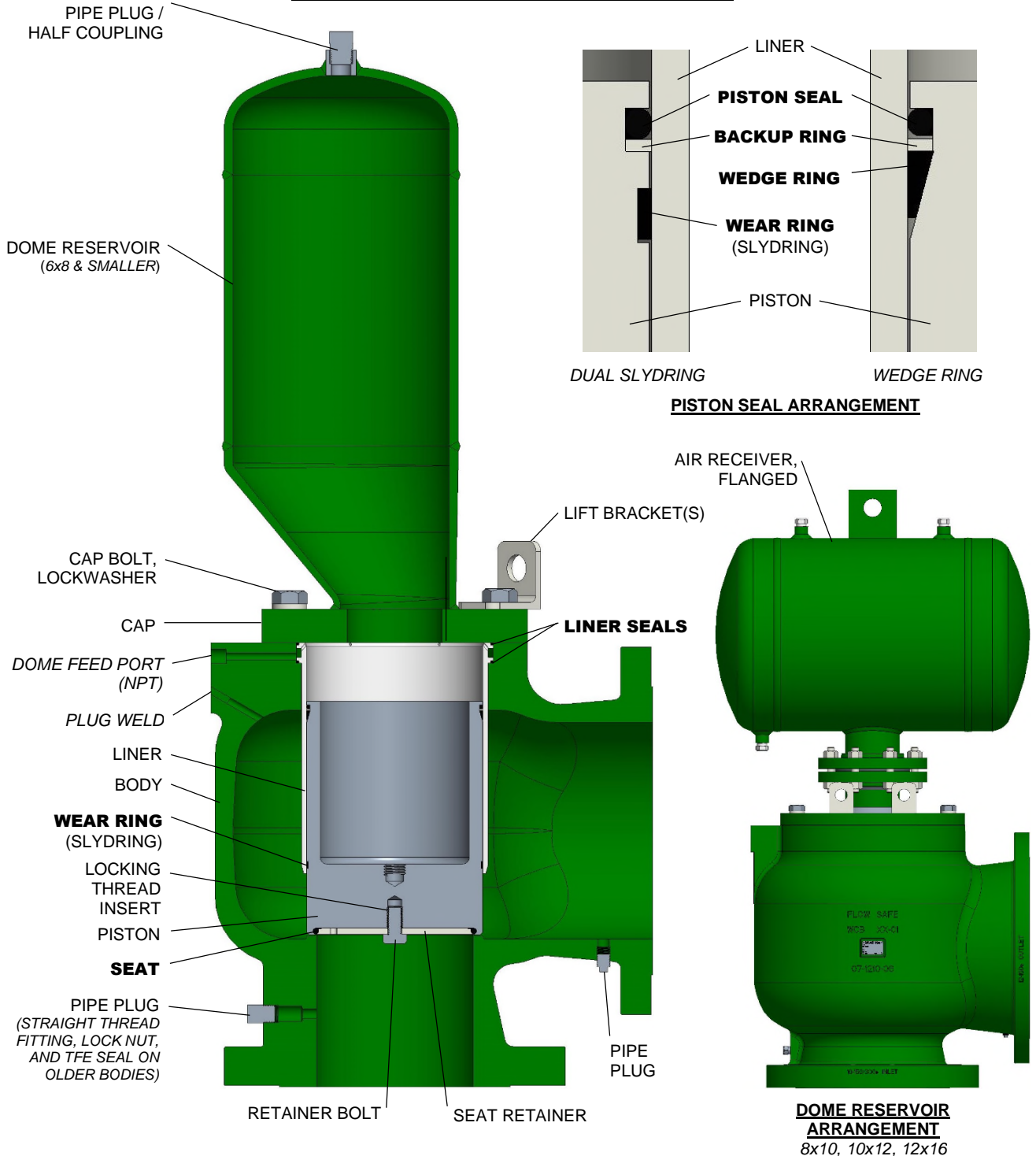

3.2 REASSEMBLY OF THE F9000 SERIES MAIN VALVE

- 1) Reassembly of these valves is basically the reverse of disassembly. Care must be taken in the handling of all items, particularly sealing surfaces and softgoods. All parts should be clean and free of any debris or contaminants.
- 2) Reinstall the liner and liner seals into the body. Do not nick or excessively stretch the liner seal O-rings. The bottom O-ring may be carefully set in its sealing area in the body before the liner is inserted, or it may be fitted onto the liner and, if necessary, held in place with a suitable lubricant (e.g., Dow Corning Molykote 33). Lightly press top seal into place in its groove, such that it is evenly spread around the liner circumference and will not be pinched by the cap.
- 3) Insert the O-ring seat into the bottom of the piston, using care to position the seat completely within the piston cavity. **NOTE** that any scratches, gouges, or particles on the seat may result in a sealing problem. Carefully position the retainer plate over the seat. Apply Loctite or Vibra-tite to the retainer bolt. Insert bolt and tighten to: 4-5 ft-lbs (1/4" bolt); 12-14 ft-lbs (3/8"); 34-37 ft-lbs (1/2"); 120 ft-lbs (3/4"). **IMPORTANT:** Retainer bolt must meet firm resistance against locking Heli-Coil in piston. Replace Heli-Coil if worn or damaged.
- 4) Install piston seal. Dow Corning Molykote 33 or equivalent may be lightly applied to the O-ring.
- 5) Fit the wear/wedge ring(s) in their proper groove in the piston assembly. On the wedge ring only, coat the outboard surface with Desco 600 grease. While holding the rings (especially the free ends) in place, lower the piston assembly into the liner. It is critically important that this installation result in even seating of the soft seat onto the raised nozzle lip in the valve body.
- 6) After checking placement of the top liner seal [see Step (2)], the valve cap can be positioned on top of the body.
- 7) The cap bolts, with washers, can then be reinserted and torqued to the values listed below.

<u>Main Valve Size</u>	<u>Cap Bolt Size</u>	<u>Torque (ft-lbs)</u>
1x2, 1-1/2x3, 2x3, 4x6 (thru ANSI 600)	1/2-13UNC	50
6x8 (old)	5/8-11UNC	65
3x4, 4x6 (ANSI 900/1500), 6x8, 8x10, 10x12, 12x16	3/4-10UNC	120

- 8) If applicable, reinstall the separate dome reservoir and any supports. If removed previously, reinstall the regulator and associated components. Apply Teflon tape or joint compound to all pipe threads.
- 9) The main valve is now completely assembled, and should be reset and tested per Section 4.0 before being returned to service.

4.0 SET PRESSURE ADJUSTMENT AND MAIN VALVE TESTING

4.1 SET PRESSURE DEFINITION

Set pressure is the inlet supply pressure at which the main valve piston begins to open. This pressure is determined by a corresponding fixed gas pressure in the dome, determined by the piston seat-to-seal area ratio for the given main valve size. Unless actual tested values are indicated on the valve tagging, the below percentages apply. Set pressure can be verified and adjusted per 4.2 (1)(b) below.

F9000 Valve Size	Dome Pressure % at Set Point *	F9000 Valve Size	Dome Pressure % at Set Point *
1 x 2	45 %	6 x 8	79 %
1-1/2 x 3	58	8 x 10	83
2 x 3	64	10 x 12	77
3 x 4	73	12 x 16	72
4 x 6	74		

* To achieve initial main valve piston lift

Example: For a 3x4 to begin discharging through the outlet at a set point of 150 psig, dome pressure is maintained at approximately 110 psig (0.73 x 150).

4.2 TESTING OF THE MAIN VALVE SUBASSEMBLY

When main valve reassembly is complete, the assembly should be tested for leakage, set pressure, and piston lift on a test stand according to the following:

- 1) To test the piston seal and liner seals, pressurize the dome with supplied gas up to the theoretical value corresponding to set pressure (see 4.1).
 - a) With no inlet pressure, test the piston seal and liner seals for leakage. Connect a bubble tester or cover the outlet with a wet paper towel or plastic wrap. Verify that there is no leakage at the valve outlet. Also verify no leakage around the cap and cap bolts by spraying the area thoroughly with soapy water.
 - b) To check set pressure, slowly pressurize the inlet with test gas or water up to the set pressure value. Set pressure is reached when there is the first small amount of flow past the piston seat to the outlet. If gas is used, this should be audible. If actual opening pressure does not match desired set pressure, adjust dome gas pressure using the regulator and record the actual dome pressure reading that corresponds to set pressure.
- 2) To test the main valve seat, re-pressurize the dome as in (1), and introduce pressure at the inlet up to 90% of set pressure. Check for leakage at the main valve outlet.
- 3) With no pressure to the dome, pressurize the inlet with air or nitrogen up to 5 psig. The piston should open slightly, allowing air to discharge through the outlet of the valve.
- 4) To check for full piston travel, install a blind flange on the valve outlet. Isolate the dome supply valve so that there is no dome pressure, and pressurize the inlet up to 5 psig. The piston should fully lift and hit the bottom of the cap; this should be an audible metallic sound. The valve should be depressurized before removing the blind flange. With no pressure to the valve inlet or dome, it should also be possible to push the piston open manually from below with an open inlet.
- 5) If any of these tests fail, disassemble the valve and examine the soft goods for contamination or damage, or consult the troubleshooting guide in Section 5.0 of this manual.

INSTALLATION, OPERATION, & MAINTENANCE MANUAL



TITLE: F9000 Series
Surge Relief Valve

Rev. D
Page 11 of 12

5.0 TROUBLESHOOTING GUIDE:

Symptom	Possible Cause	Remedy
The main valve leaks around the cap.	Inadequate or uneven bolt torque.	Retighten the cap bolts per Section 3.2.
	Sealing surface on cap is damaged.	Repair defect or replace cap.
	Upper liner seal is damaged or contaminated.	If damaged, replace with new seal(s). If contaminated, clean and reinstall.
The main valve leaks through the outlet.	Damage to, or contamination on: piston seat or main valve nozzle, piston seal / sealing surface, or lower liner seal / sealing surface.	Disassemble the valve, remove the piston and liner, and examine the seat, seals, and sealing surfaces under magnification. If damaged, replace with new part(s); if contaminated, clean and reinstall.
	Dome is not loading properly through regulator.	See "The main valve does not close."
The main valve does not close.	Obstruction in dome gas supply fittings or components.	Clean / unplug.
	Regulator has malfunctioned or is improperly set.	Test regulator for adjustability and proper output (See Section 4.1). Repair / replace as necessary.
	Piston is stuck in liner.	Disassemble and ensure wear rings / wedge ring are completely in groove. Check for excessive debris or damage to piston or liner.
	Seat or piston / liner seal is leaking, preventing piston from reseating.	Disassemble valve; check the seat and seals for damage or improper installation. Replace / reinstall as necessary.
The main valve does not open.	Regulator has malfunctioned or is improperly set.	Test regulator for adjustability and proper output (See Section 4.1). Repair / replace as necessary.
	Inlet line blocked.	Clear blockage in a safe manner.
	Outlet line blocked.	Clear blockage in a safe manner.
	Piston is stuck in liner.	Disassemble and ensure wear rings / wedge ring are completely in groove. Check for excessive debris or damage to piston or liner.

INSTALLATION, OPERATION, & MAINTENANCE MANUAL



TITLE: F9000 Series
Surge Relief Valve

Rev. D
Page 12 of 12

6.0 SOFTGOODS KITS

NOTE: Provide valve serial number(s) whenever possible when ordering softgoods kits.

Valve Size	Kit Part Number
1 x 2	MV75-01X02- DXY
1-1/2 x 3	MV75-15X03- DXY
2 x 3	MV75-02X03- DXY
3 x 4	MV75-03X04- DXY
4 x 6	MV75-04X06- DXY
6 x 8	MV75-06X08- DXY
8 x 10	MV75-08X10- DXY
10 x 12	MV75-10X12- DXY
12 x 16	MV75-12X16- DXY

<u>X / Y = Seat / Seal Material</u>		<u>D = Seat Hardness</u>	
Code		Code	
B	Buna-N	5	Soft: ≤ 50 psig
V	Viton	7	Medium: 51-999 psig
U	Polyurethane	9	Hard: ≥ 1000 psig
E	EPR / EPDM	0	"Universal": 1 each of above seats
Z	Kalrez		
C	Chemraz		
N	Lo-temp nitrile (Buna-N)		

Most common materials listed; contact Flow Safe for availability of other materials.

Seat hardness vs. set pressure listings are approximate only.

Main Valve Softgoods Kit contents (see page 8):

<u>Standard kit</u>	<u>Qty.</u>
Seat	1
Liner seal	2
Piston seal	1
Piston seal B/U ring	1
Wear ring	2 *
Rear Teflon seal	1 **

* Wedge ring substituted for one wear ring for applicable valves (provide serial number).

** For valves without NPT-type plug near inlet.