



F84L & F88 Series
*Spring-Operated Liquid Service
Pressure Relief Valves*

"EXPERTS IN SOFT SEAT VALVE TECHNOLOGY"

CONTENTS

<i>SECTION</i>	<i>PAGE</i>
Introduction and Features.....	2
Operation.....	3-4
Applications & Education	4-5
Valve Selection	6
Service Envelope.....	6
Dimensions & Weights	7
Construction, F84L	8-9
Construction, F88	10-11
Sizing and Capacities	12-14
Part Numbering.....	15
Other Flow Safe Products.....	Back Cover

The policy of FLOW SAFE and its authorized assemblers is a commitment to value through:

- Environmentally compatible products
- Cost-efficient design with minimal parts
- Quality products, readily available
- Flexibility to meet unique customer needs
- “No-hassle” service

INTRODUCTION AND FEATURES

Today's process industries require leak-tight pressure relief valves to reduce emissions and to save customer product.

The **F84L** and **F88** Series “High Performance” liquid relief valves accomplish leak-tight seating with accurate and consistent operational characteristics.

F84L and **F88** design features include:

- Balanced against the effects of backpressure without bellows
- High backpressure (99%) capability with no effect on setpoint
- Spindle seal orientation prevents media back-flow to inlet
- Strong discharge coefficients provide for large flow capabilities
- Certified for liquid service per ASME Section XIII; ‘CE’ Mark available
- F88 series also certified per ASME Section XIII for gas service
- Stable under all load conditions and fully open by 10% overpressure per ASME
- Repeatable leak-tight seating
- In the larger sizes, a spindle (disk) seal is proportionally loaded to system pressure or spring-energized to provide smooth opening and reseal
- Fixed blowdown of approx. 20% at most pressure ranges, and modulating action at low-flow conditions
- Standard 316/316L SS trim for superior corrosion resistance
- Available in a variety of materials and connections, including NPT, flanges, SAE, AS5202 (MS), and Grayloc.
- 30 to 24,277 psig (2.1 to 1674 barg) pressure range
- -65 to 500 °F (-54 to 260 °C) service temperature range

F88: US Patent No. 7,513,270

OPERATION

F84L / F88 Series

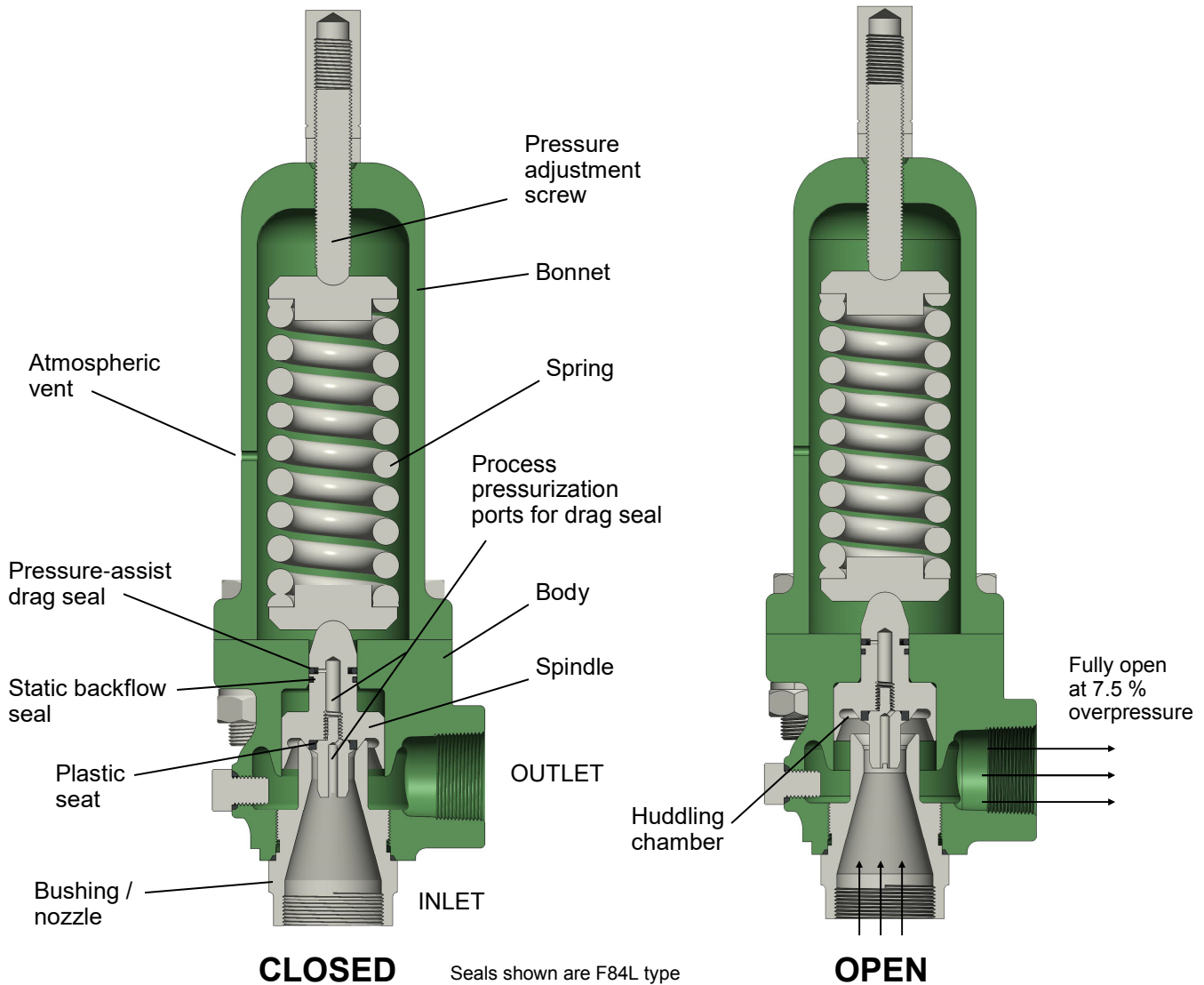

The Flow Safe **F84L** and **F88** Series liquid relief valves are designed to provide customers with a stable, smooth-flowing relief valve with substantial capacity. Below the set point, pressure acting upon the valve spindle/seat surface generates a lifting force, $F = P \times A$. This opening force is opposed by the spring closing force. At set point, as the seat starts to lift off the nozzle, an additional force is created in the 'huddling chamber' to boost the effective force due to pressure. At approximately 7.5% above set pressure, the combined upward forces cause the spindle to pop open to full lift.

The larger F84L sizes achieve stability through the use of a process-pressurized drag seal on the spindle. This O-ring helps dampen the movement of the spindle to prevent flutter or chatter. F88's use a spring-energized Teflon seal. In all sizes, the spindle seal diameter is the same as the seat diameter, which makes the valves balanced against backpressure without the use of bellows. After the valve fully opens, blowdown is typically a fixed 20% on the larger sizes, and 30% for the F84L-2. At very low flow rates, the F84L can modulate open to relieve the upset and softly reclose at up to the nominal blowdown value. Strong coefficients of discharge K_d allow for smaller valves to be used, lending additional value by reducing the user's capital costs. For water service over 140 °F, a lift lever can be provided except on the F84L-2.

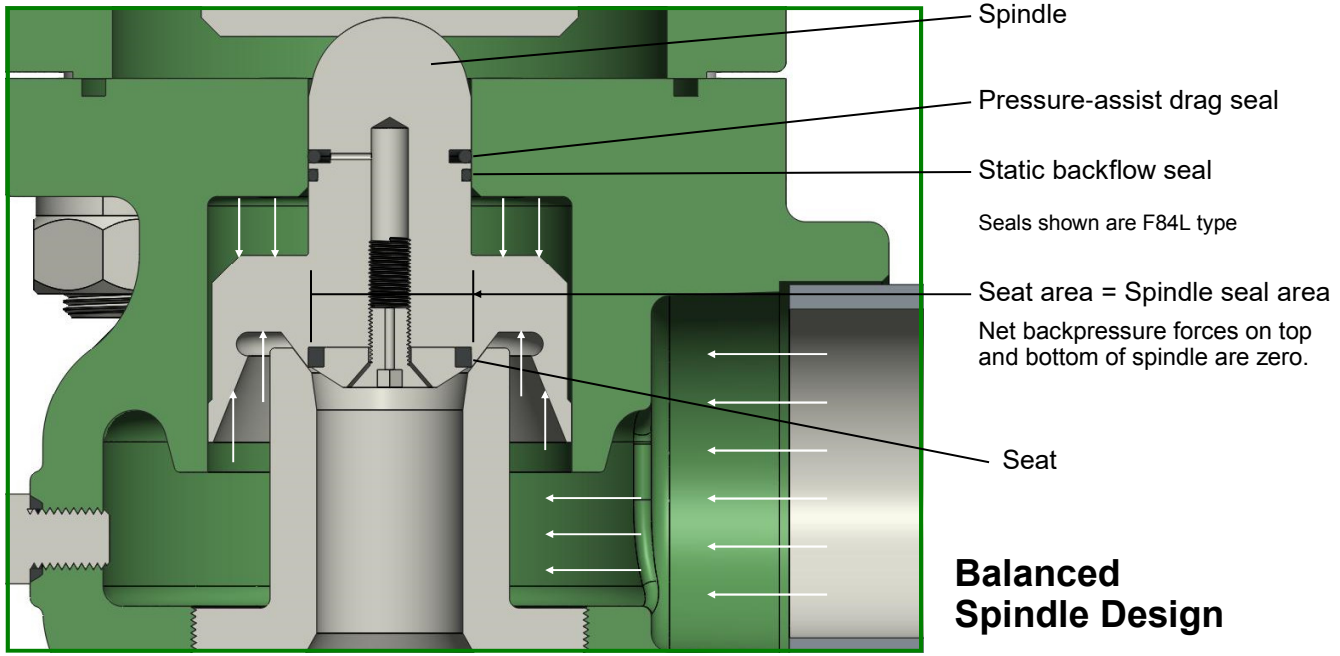

APPLICATIONS & EDUCATION

Many incompressible liquid processes today challenge relief valves to open stably without flutter and to be accurate with respect to set point and reseal point. This is particularly true when these systems are affected by pulsations and vibrations created by positive displacement pumps. The **F84L** and **F88** Series relief valves excel in these difficult applications. The valve is designed to open and provide smooth flow performance during a relief cycle because of the pressurized drag seal or static spring-energized seal that dampens spindle movement, helping to avoid damaging “water hammer” effects.

Many liquid services are closed-loop, with the relief valve discharge connection hard-piped back to the process or to a pressurized reservoir. The Flow Safe F84L and F88 relief valves are ideal in these situations, as they are balanced against the effects of backpressure without bellows. Bellows add significant cost to relief valves, and manufacturers typically don't warrant them against failure. And because they can easily be damaged, bellows are limited to moderately low levels of backpressure.



Mixed-phase applications can be readily handled by the F84L and F88 when the major component of the fluid stream is liquid. Since the F88 is also capacity-certified on gas, this model can also be installed in applications where fluid phase characteristics are highly variable and alternate between gas and liquid. The ASME Code and National Board of Boiler & Pressure Vessel Inspectors rules do not give specific guidance on nameplate stamping (i.e., capacity) in mixed-phase applications. However, good engineering judgment would dictate that the valve be marked for gas or liquid based on the fluid that makes up the greater percentage of the flow stream.

These valves are ideal in handling lube oil systems (including API 614) and seal oil systems. Many F84L valves are serving in water systems, including deionized water, and high-pressure temper quench systems in the steel industry. Flow Safe F84L and F88 valves are protecting equipment in food handling, compressor and rotating equipment lubrication systems, and chemical processing, in some cases with highly viscous fluids.

Care should be exercised when applying pressure relief valves to systems with viscous fluids, to make sure an adequate relief valve orifice size is chosen. At most pressures, low-viscosity fluids such as water and many natural gas liquids will flow through piping, valves, and fittings in a turbulent flow pattern, with essentially uniform velocity distribution and random movement of fluid particles across the pipe. Thicker, more viscous fluids such as oils would tend to flow in a laminar pattern, with velocity gradually increasing from near zero at the pipe wall to a maximum value at the center-line. As a measure of the degree of laminar or turbulent flow, the Reynolds number is a dimensionless parameter that can be calculated based on flow quantity, fluid viscosity and specific gravity, and internal flow area. As outlined in the valve sizing guidelines on pages 12 and 13, a viscosity correction factor should be determined based on the Reynolds number and factored into the orifice area sizing calculation.

Some closed-loop systems can have pressure present at the outlet of a relief valve with the inlet completely depressurized. Effective sealing of the spindle or disk must be engineered so as to prevent back-flow of the fluid into the inlet. As such leakage could occur if the pressure-assist drag seal were the only spindle seal, Flow Safe's F84L has a second O-ring (static backflow seal) below the drag seal to isolate backpressure from it.

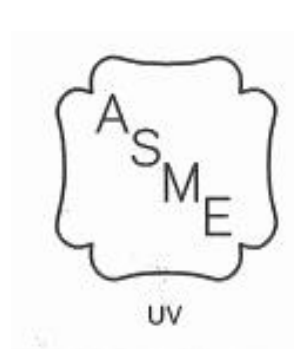
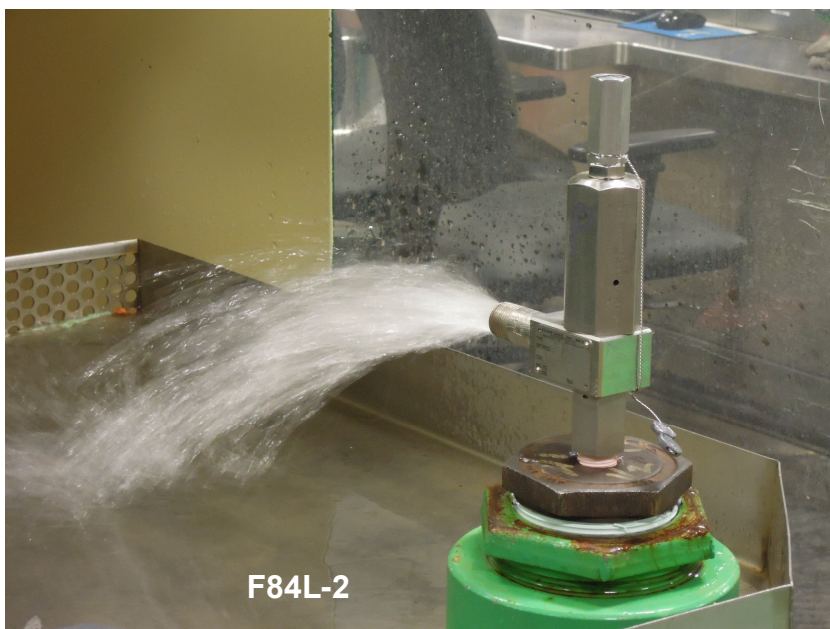

Comparison Between Spring & Pilot Operated Relief Valve Performance

In addition to the F84L and F88, Flow Safe manufactures high-performance liquid pilot-operated relief valves — the F7000/8000 Series. The following table illustrates general selection considerations for both series. See F7000/8000 catalog for more information about that series.

F84L or F88 (Spring-operated)	F7000 / F8000 (Pilot-operated)
Competitive, especially in smaller sizes	Generally more expensive, except more competitive in larger sizes
10% overpressure standard	Valves can modulate fully open with zero overpressure
Orifices available: -2, -3, -4, -8, -G, -J (0.015 to 1.69 in ²)	Orifices available: D - W and full-bore (0.134 to 112 in ²)
Seat options: Teflon (PTFE), Kel-F (PCTFE), Vespel, PEEK	Seat options: Teflon (PTFE), Kel-F (PCTFE), Vespel, PEEK; or Elastomer O-ring
Seal options: Elastomer O-ring (F84L); Teflon (F88)	Seal options: Elastomer O-ring or Teflon
Connections: 1/2" x 1/2" to 2" x 3" NPT 1/2" x 1/2" to 6" x 6" Flanged	Connections: 1" x 2" to 1-1/2" x 3" NPT 1" x 2" to 12" x 16" Flanged
Pressure range: 30 - 24,277 psig (2.07 - 1674 barg) 50 psig min. for F88's, F84L-2, and F84L-3	Pressure range: 15 - 6,000 psig (1 - 413.8 barg)
Balanced against backpressure	Balanced against backpressure
Leak-tight to 90-95% of set pressures > 100 psig (For F84L-2, 90% of set pressures > 300 psig)	Leak-tight to 96% of set pressure
Action: Modulates at low flow, then pop-action	Action: Modulating action only (F100 or F300 flowing pilots, or F500 non-flowing pilot)
No field test connection available	Field test connection available

SERVICE ENVELOPE

Orifice Size		- 2 ²	- 3	- 4	- 8	- G	- J
Orifice Dia., in (mm)		0.138 (3.5)	0.287 (7.3) ³	0.384 (9.8) ³	0.577 (14.7)	0.919 (23.3)	1.467 (37.3)
Orifice Area, in ² (mm ²)		0.015 (9.7)	0.065 (41.9)	0.116 (74.8)	0.261 (168)	0.663 (428)	1.690 (1090)
Min. Set Pressure, psig (barg)		50 (3.45)		F84L: 30 (2.07) F88: 50 (3.45)			
Maximum Set Pressure, psig (barg) ¹	Micro body (2-piece)	24,277 (1674)	—	—	—	—	—
	Std. C, D, E body	—	720 (49.6)	720 (49.6)	720 (49.6)	668 (46)	298 (20.5)
	XL bonnet	—	4,292 (296)	4,292 (296)	4,292 (296)	3,705 (255)	2,700 (186)
	XXL bonnet	—	8,382 (578)	8,382 (578)	—	—	—
Service Temp. Range, °F (°C)	F84L	CS	-20 to 500 (-29 to 260)				
		SS	-65 to 500 (-54 to 260)				
	F88	CS	-20 to 400 (-29 to 204)				
		SS	-423 to 400 (-252 to 204)				

¹ Pressure ratings are for standard carbon steel or stainless steel construction.

² The - 2 orifice size available in F84L only.

³ Equivalent orifice diameter (actual orifice is annular area).

DIMENSIONS & WEIGHTS

F84L / F88 Series

Refer to figures on pages 8 and 10.

Orifice Size	Weight ¹ , lb (kg)	Standard Connections ²		Dimensions, in (mm) ¹		
		Inlet	Outlet	A	B	C
- 2	3.0 (1.4)	1/2", 3/4" FNPT	1/2", 3/4" FNPT	2.14 (54)	1.50 (38)	8.9 (226)
- 3	12.3 (5.6)	1/2", 3/4", 1" FNPT	1" FNPT	2.65 (67)	2.07 (53)	13.1 (333)
- 4	12.3 (5.6)	1/2", 3/4", 1" FNPT	1" FNPT	2.65 (67)	2.07 (53)	13.1 (333)
- 8	12.3 (5.6)	3/4", 1" FNPT	1" FNPT	2.65 (67)	2.07 (53)	13.1 (333)
- G	41 (19)	1-1/2" FNPT	2" FNPT	2.60 (66)	3.15 (80)	17.8 (452)
- J	70 (32)	2" FNPT	3" FNPT	2.72 (69)	4.25 (108)	22.0 (559)
Flanged Connections						
- 2	7 (3.2)	1/2" 150 - 600#	1/2" 150#	3.79 (96)	4.75 (121)	10.6 (269)
	9 (4.1)	1/2" 900 - 1500#	1/2" 300#	4.35 (110)	4.75 (121)	10.3 (262)
	12 (5.4)	1/2" 2500#	1/2" 300#	4.85 (123)	4.75 (121)	10.8 (274)
- 3	20 (9.1)	1" 150 - 600#	1" 150#	4.72 (120)	4.75 (121)	15.2 (386)
	29 (13.2)	1" 900 - 2500#	1" 300#	5.72 (145)	6.75 (171)	16.2 (411)
- 4	20 (9.1)	1" 150 - 600#	1" 150#	4.72 (120)	4.75 (121)	15.2 (386)
	29 (13.2)	1" 900 - 2500#	1" 300#	5.72 (145)	6.75 (171)	16.2 (411)
- 8	19 (8.6)	1" 150 - 600#	1" 150#	4.72 (120)	4.75 (121)	15.2 (386)
	29 (13.2)	1" 900 - 2500#	1" 300#	5.72 (145)	6.75 (171)	16.2 (411)
- G	54 (25)	1-1/2" 150 - 600#	2" 150#	4.87 (124)	4.75 (121)	20.0 (508)
	63 (29)	1-1/2" 900 - 1500#	2" 300#	5.25 (133)	5.06 (129)	20.4 (518)
- J	91 (41)	2" 150 - 600#	3" 150#	5.37 (136)	6.50 (165)	24.8 (630)
	110 (50)	2" 900 - 1500#	3" 300#	6.56 (167)	7.00 (178)	26.0 (660)

¹ Data shown is typically for largest bonnet / flange / spring range. Contact Flow Safe for submittal drawing whenever specific dimensions are needed for construction. API 526 dimensions available on request for applicable orifice sizes.

² Other available connections include SAE and MS / AS5202 thread bosses, and Grayloc hub. Minimum inlet size per ASME VIII is 1/2" for liquid valve.

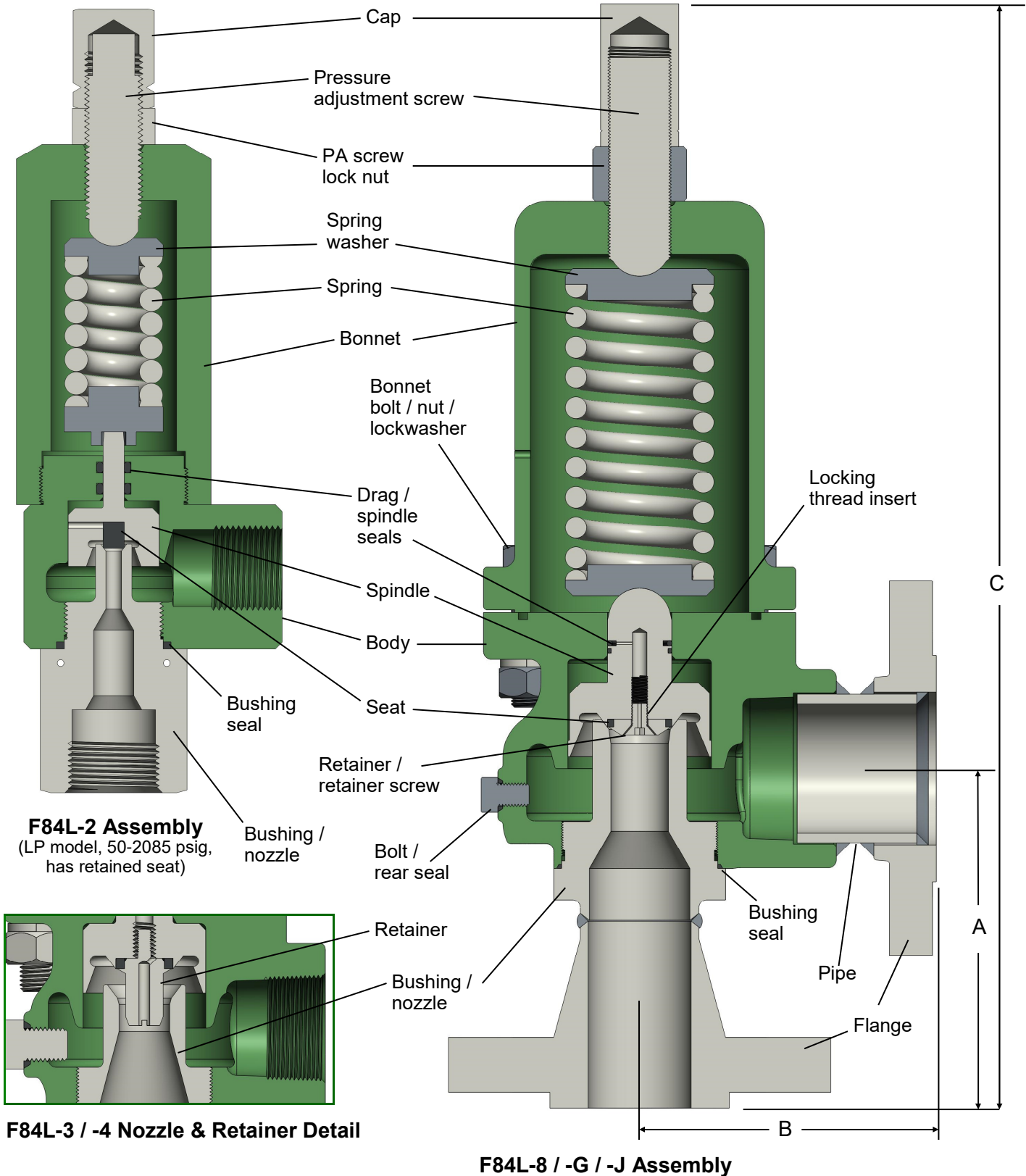

F84L Part Name	Standard Materials of Construction ¹	
	Carbon Steel	Stainless Steel
Body (-3, -4, -8, -G, -J)	SA-351 CF8M	SA-351 CF8M
Body (-2)	SA-479 316/316L	SA-479 316/316L
Bonnet (-3, -4, -8, -G, -J)	SB-221 6061 or SA-216 WCB	SA-479 316/316L or SA-351 CF8M
Bonnet (-2)	SA-479 316/316L	SA-479 316/316L
Spring	A401 chromium-silicon	A313 302/304 or 17-7
Spring washer	Carbon steel / plated	A479 316/316L
Cap	6061 Aluminum	6061 Aluminum
Pressure adjustment screw	Carbon steel / plated	A479 316/316L
PA screw lock nut	316 SS	316 SS
Bonnet bolt	SA-193 Gr. B8	SA-193 Gr. B8
Nut	SA-194 Gr. 8	SA-194 Gr. 8
Lockwasher	316 SS	316 SS
Bushing / nozzle	SA-479 316/316L or SA-564 630 ⁴	SA-479 316/316L or SA-564 630 ⁴
Spindle	A479 316/316L	A479 316/316L
Seat	Plastic ²	Plastic ²
Retainer	A479 316/316L	A479 316/316L
Retainer screw (-2LP, -8, -G, -J)	316 SS	316 SS
Locking thread insert	304 SS ³	304 SS ³
Drag & spindle seals	Elastomer	Elastomer
Bolt	316 SS	316 SS
Bushing & rear seals	Teflon / PTFE	Teflon / PTFE
Flanges (optional)	SA-105	SA-182 F316/316L
Pipe (optional)	SA-106 B or SA-53 E/B	SA-312 316/316L

¹ Materials are subject to change without notice. Contact Flow Safe for availability of materials not shown.

² See "Seat / Seal Data" below for selections.

³ Inconel X750 provided for service in accordance with NACE MR0175 / ISO 15156.

⁴ SA-564 630 (17-4 PH) used for most applications above 10,000 psig.

SEAT / SEAL DATA - F84L

Seat Material	Continuous Process Temperature, °F (°C)		Pressure Range, psig (barg)	
	Min.	Max.	- 2	- 3, - 4, - 8, - G, - J
Teflon ® (PTFE)	-65 (-54)	400 (204)	200-500 (13.8-34.5)	30-900 (2.1-62)
Kel-F (PCTFE)	-65 (-54)	400 (204)	501-1000 (34.6-69)	901-1500 (62.1-103.4)
Polyimide or Polyamide-imide - Vespel ®, Duratron ®, or equal	-65 (-54)	500 (260)	> 1000 (69)	> 1500 (103)
Polyetheretherketone (PEEK)	0 (-17)	525 (274)	> 800 (55)	> 900 (62)
Seal Material				
Buna-N	-30 (-34)	275 (135)		
Fluorocarbon - Viton ® or equal	-30 (-34)	400 (204)		
Ethylene propylene (EPR / EPDM)	-65 (-54)	325 (163)		
Perfluoroelastomer - Kalrez ® or equal	0 (-18)	525 (274)		

Teflon, Vespel, Viton, and Kalrez are registered trademarks of E.I. Du Pont de Nemours and Co. or affiliates. Duratron is a registered trademark of Mitsubishi Chemical Advanced Materials.

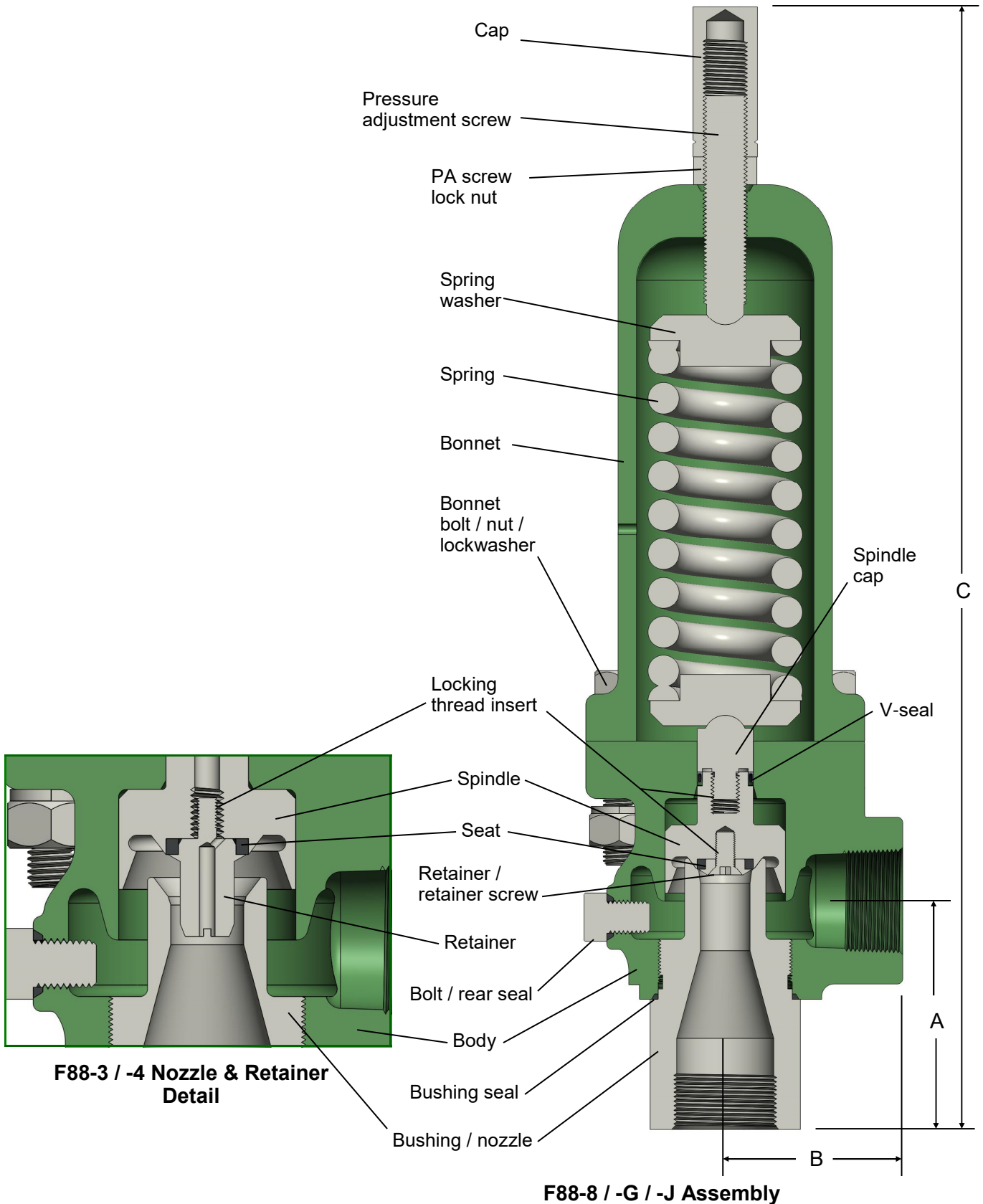

F88 Part Name	Standard Materials of Construction ¹	
	Carbon Steel	Stainless Steel
Body	SA-351 CF8M	SA-351 CF8M
Bonnet	SB-221 6061 or SA-216 WCB	SA-479 316/316L or SA-351 CF8M
Spring	A401 chromium-silicon	A313 302/304 or 17-7 SS
Spring washer	Carbon steel / plated	A479 316/316L
Cap	6061 Aluminum	6061 Aluminum
Pressure adjustment screw	Carbon steel / plated	A479 316/316L
PA screw lock nut	316 SS	316 SS
Bonnet bolt	SA-193 Gr. B8	SA-193 Gr. B8
Nut	SA-194 Gr. 8	SA-194 Gr. 8
Lockwasher	316 SS	316 SS
Bushing / nozzle	SA-479 316/316L	SA-479 316/316L
Spindle	A479 316/316L	A479 316/316L
Spindle cap	A479 316/316L	A479 316/316L
Seat	Plastic ²	Plastic ²
Retainer	A479 316/316L	A479 316/316L
Retainer screw (-8, -G, -J)	316 SS	316 SS
Locking thread insert	304 SS ³	304 SS ³
V-seal	Teflon w/316 SS spring ⁴	Teflon w/316 SS spring ⁴
Bolt	316 SS	316 SS
Bushing & rear seals	Teflon / PTFE	Teflon / PTFE
Flanges (optional)	SA-105	SA-182 F316/316L
Pipe (optional)	SA-106 B or SA-53 E/B	SA-312 316/316L

¹ Materials are subject to change without notice. Contact Flow Safe for availability of materials not shown.

² See "Seat / Seal Data" below for selections.

³ Inconel X750 provided for service in accordance with NACE MR0175 / ISO 15156.

⁴ Elgiloy or Inconel X750 spring provided for service in accordance with NACE MR0175 / ISO 15156.

SEAT / SEAL DATA - F88

Seat Material	Continuous Process Temperature, °F (°C)		Pressure Range, psig (barg)
	Min.	Max.	
Teflon ® (PTFE)	-423 (-252)	400 (204)	50-900 (2.1-62)
Kel-F (PCTFE)	-423 (-252)	400 (204)	901-1500 (62.1-103.4)
Polyimide or Polyamide-imide — Vespel ®, Duratron ®, or equal	-423 (-252)	400 (204)	> 1500 (103)
Polyetheretherketone (PEEK)	0 (-17)	400 (204)	> 900 (62)
Seal Material			
Teflon ® (PTFE)	-423 (-252)	400 (204)	

Teflon, Vespel, Viton, and Kalrez are registered trademarks of E.I. Du Pont de Nemours and Co. or affiliates. Duratron is a registered trademark of Mitsubishi Chemical Advanced Materials.

The ASME Boiler & Pressure Vessel Code, Section XIII, requires that capacity certification be obtained for pressure relief valves designed for liquid service. Certification tests include determination of the rated coefficient of discharge for the PRVs at an overpressure of 10% or 3 psi, whichever is greater.

To size the F84L and F88 Series liquid service relief valve, the following information is required:

- Required flow capacity
- Required set pressure
- Backpressure (pressure at valve outlet)
- Acceptable overpressure (10% or 3 psi max.)
- Operating pressure, to assure that it is below valve reseal pressure
- Fluid properties, including viscosity and specific gravity

To select the required orifice size for a liquid application, the following equations should be used:

In US customary units:

$$A = \frac{Q}{38K_d K_w K_c K_v} \sqrt{\frac{G}{P_1 - P_2}}$$

In SI units:

$$A = \frac{11.78 Q}{K_d K_w K_c K_v} \sqrt{\frac{G}{P_1 - P_2}}$$

For viscous liquid service, determine preliminary orifice area A using 1.0 for K_v in the above equations. Then select the next larger Flow Safe orifice area for determining Reynolds number (Re) below. Using Re, determine K_v from graph on p. 13 for final calculation of A.

In US customary units:

$$Re = \frac{Q(2800G)}{\mu \sqrt{A}} \quad \text{or} \quad Re = \frac{12,700Q}{U \sqrt{A}}$$

In SI units:

$$Re = \frac{Q(18,800G)}{\mu \sqrt{A}} \quad \text{or} \quad Re = \frac{85,220Q}{U \sqrt{A}}$$

- A = Required discharge orifice area, in² or mm²
- Q = Required flow rate, US gpm or liters/min
- K_d = Rated ASME discharge coefficient (see p. 14 for F84L & F88)
- K_w = Backpressure correction factor, for balanced bellows valves only (otherwise, use 1.0)
- K_c = Rupture disk correction factor:
1.0 with no disk
0.9 with disk in combination
- K_v = Viscosity correction factor (from graph on p. 13)
- G = Specific gravity (water = 1.0 at standard conditions)
- P_1 = Inlet pressure (including overpressure), psig or kPag
- P_2 = Total backpressure, psig or kPag
- Re = Reynolds number
- μ = Absolute viscosity at flowing temperature, centipoise (cP)
- U = Kinematic viscosity at flowing temperature, Saybolt universal seconds (SUS or SSU)

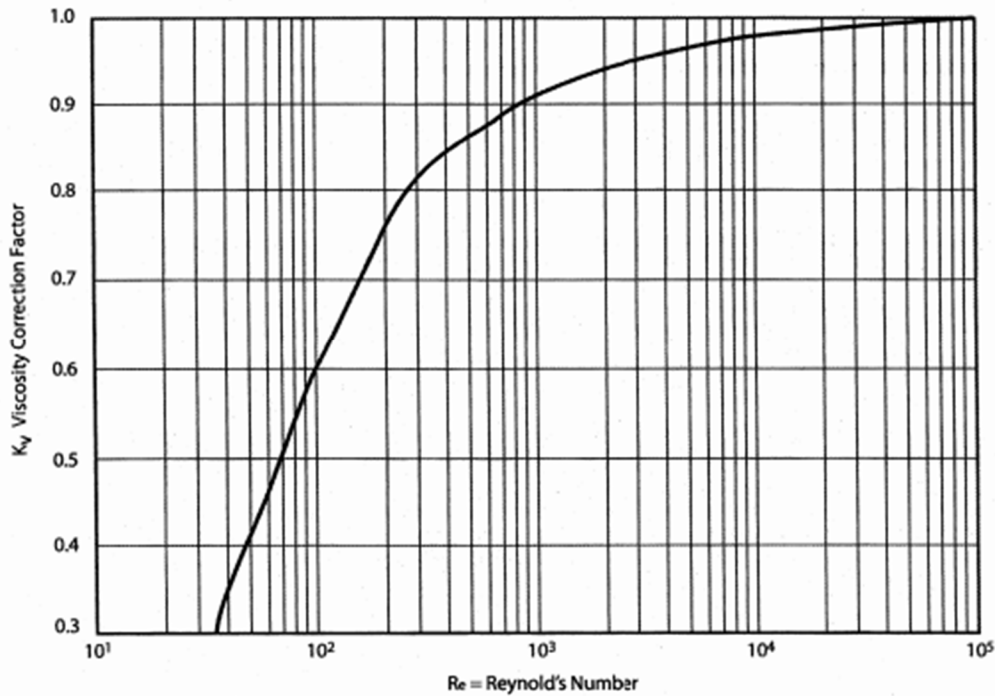

SIZING EXAMPLE

Service conditions: Set pressure = 200 psig; 10% overpressure; zero backpressure
 Mineral oil, SAE 20W at 0 °F: Viscosity = 5000 cP; SG = 0.91
 Capacity required = 125 gpm
 Assume Flow Safe F84L with $K_d = 0.798$; initial $K_v = 1.0$

$$\begin{aligned} \text{Preliminary area, } A &= \frac{Q}{38K_dK_wK_cK_v} \sqrt{\frac{G}{P_1 - P_2}} \\ &= \frac{125}{38(0.798)(1)(1)(1)} \sqrt{\frac{0.91}{220 - 0}} = 0.265 \text{ in}^2 \end{aligned}$$

Select F84L-G with 0.663 in² orifice area (from service envelope table on p. 6 or capacity table on p. 14).

Mineral oil is a viscous liquid, so its viscosity factor (K_v) must be determined to see the effect on calculated area. First, determine flow (Q) through the selected orifice using K_v for water (1.0); then use that flow to calculate Reynolds number (Re). Finally, determine K_v based on Reynolds number and recalculate the area.

$$Q = 38AK_dK_wK_cK_v \sqrt{\frac{P_1 - P_2}{G}} = 38(0.663)(0.798)(1)(1)(1)(220/0.91)^{1/2} = 313 \text{ gpm}$$

$$Re = \frac{Q(2800G)}{\mu(A)^{1/2}} = \frac{313(2800)(0.91)}{5000(0.663)^{1/2}} = 196$$

From graph above, $K_v = 0.75$ for $Re = 196$ (1.96×10^2)

$$\text{Final area, } A = \frac{125}{38(0.798)(1)(1)(0.75)} \sqrt{\frac{0.91}{220 - 0}} = 0.353 \text{ in}^2 \longrightarrow \text{Initial selection of F84L-G (0.663 in}^2\text{) is confirmed.}$$

FLOW CAPACITIES - GPM of WATER, 70 °F, Sp. Gravity = 1.0 10% Overpressure, Zero Backpressure

Orifice Size	- 2	- 3	- 4	- 8	- G	- J
Orifice Area, in ² (mm ²)	0.015 (9.7)	0.065 (41.9)	0.116 (74.8)	0.261 (168)	0.663 (428)	1.690 (1090)
ASME Discharge Coeff. K _d	0.635/0.619 ¹	0.838 ²	0.859 ³	0.798	0.798	0.798
Set Pressure, psig	gpm	gpm	gpm	gpm	gpm	gpm
30	---	---	21.7	45	115	294
40	---	---	25.1	52	133	339
50	2.7	15.4	28.1	58	149	380
60	2.9	16.8	30.7	64	163	416
70	3.1	18.2	33.2	69	176	449
80	3.4	19.4	35.5	74	188	480
90	3.6	20.6	37	78	200	509
100	3.8	21.7	39	83	210	537
125	4.2	24.2	44	92	235	600
150	4.6	26.6	48	101	258	658
175	5.0	28.7	52	109	279	711
200	5.3	30	56	117	298	760
400	7.6	43	79	166	421	1075
600	9.3	53	97	203	516	1316
800	10.7	61	112	234	596	1520
1000	12.0	68	125	262	666	1699
1500	14.7	84	153	321	816	2081
2000	17.0	97	177	371	943	2403
2500	18.5	108	198	415	1054	2687
2700	19.2	112	206	431	1095	2792
3000	20.3	118	217	454	1155	---
3500	21.9	128	234	491	1247	---
3705	22.5	132	241	505	1283	---
4000	23.4	137	251	525	---	---
4292	24.2	142	260	543	---	---
5000	26.2	153	280	---	---	---
6000	28.6	168	307	---	---	---
7000	30.9	181	332	---	---	---
8000	33.1	194	355	---	---	---
8382	33.9	198	363	---	---	---
10000	37	---	---	---	---	---
12000	40	---	---	---	---	---
14000	43	---	---	---	---	---
16000	46	---	---	---	---	---
18000	49	---	---	---	---	---
20000	52	---	---	---	---	---
22000	54	---	---	---	---	---
24277	57	---	---	---	---	---

¹ Equivalent K_d shown: From 50 to 2085 psig (K_d = 0.635), ASME certified value is "flow factor" of 0.362 gpm / √psid
Above 2085 psig (K_d = 0.619), ASME certified value is "flow factor" of 0.353 gpm / √psid

² Equivalent K_d shown. ASME certified value is "flow factor" of 2.07 gpm / √psid

³ Equivalent K_d shown. ASME certified value is "flow factor" of 3.79 gpm / √psid

PART NUMBERING

F84L / F88 Series

S 8 L G D - 1 5 R F 2 - 0 2 R F 1 - C S - S S - K V N

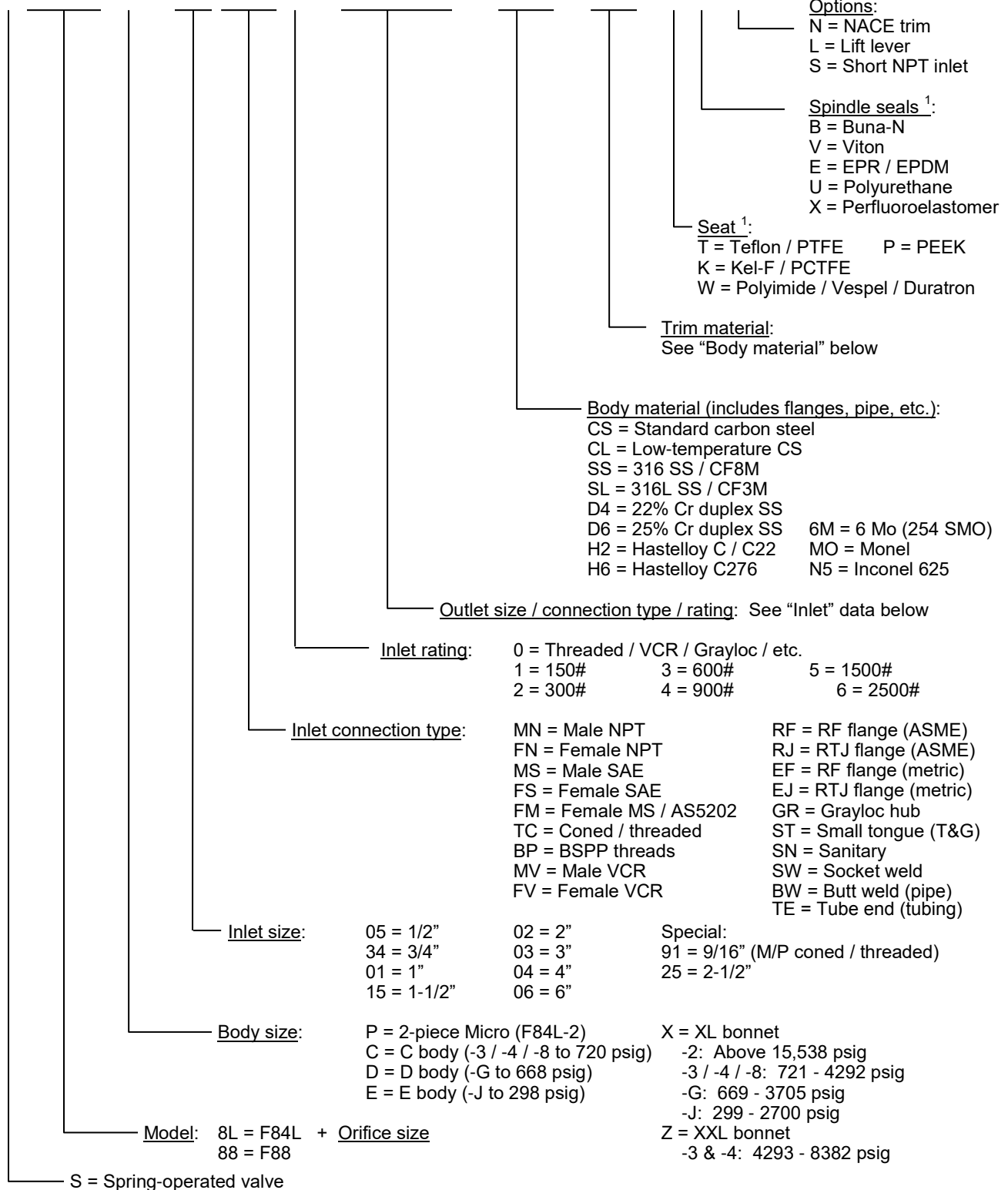

¹ See pp. 9, 11 for details on seats and seals

Experts in Soft-Seated Technology



F84/85/88 Series
Safety Relief Valve (Gas) - ASME VIII



F7000/8000 Series
Pilot-Operated Relief Valve - ASME VIII



F70U Series
Unloader Valve



F9000 Series
Liquid Surge Relief



F70PR Series
Pilot-Operated Relief Valve - DOT

Leaders in “true” High Performance with
commitment to value through:

- Soft seats offering unsurpassed tightness
- Large coefficients and orifice areas = Best capacities
- Backpressure-balanced without bellows
- ASME Sec. VIII, API, DOT, ISO 9001, CE, Marine class societies (e.g., DNV, BV)
- Trained representatives with solid factory support
- Quick-ship program through Flow Safe Supply

Texas Office

Flow Safe, Inc.
16240 Port Northwest Drive
Houston, TX 77041
P: (832) 678-2070
F: (716) 662-2580

New York Office

Flow Safe, Inc.
3865 Taylor Road
Orchard Park, NY, USA 14127
P: (716) 662-2585
F: (716) 662-2580

© 2022 Natural Gas Solutions North America, LLC - All rights reserved. Flow Safe reserves the right to make changes in specifications and features shown herein, or discontinue the product described at any time without notice or obligation. Contact your Flow Safe representative for the most current information.



www.flowsafe.com