



F80M (F80 'Micro') Series Safety Relief Valve

- TYPES F84M (PLASTIC-SEATED) / F85M (ELASTOMER-SEATED)
- -1,-2,-3,-4 Orifices



INSTALLATION, OPERATION, & MAINTENANCE MANUAL

Revision: G
Date of Issue: Oct. 21, 2011

Approved by: *NRT*
Design Engineer

 JWO
Engineering Mgr.

TABLE OF CONTENTS

<u>Topic</u>	<u>Page</u>
1.0 General	3
2.0 Description, Operation, Service Envelope, Installation, & Startup	
2.1 Description / Operation	4
2.2 Service Envelope	4
2.3 Installation.....	5
2.4 Startup	5
3.0 Valve Maintenance	
3.1 Disassembly.....	6
3.2 Reassembly.....	6
4.0 Valve Testing and Adjustment	
4.1 Test Equipment.....	7
4.2 Setting / Adjustment Tolerances	7
4.3 Set Pressure and Blowdown Adjustments	7
4.4 Seat Tightness	8
5.0 Softgoods Kits.....	8
6.0 Troubleshooting Guide	9

Illustrations

F84M 'A' Body (Integral Bonnet) Assembly.....	11
F85M 'A' Body (Integral Bonnet) Assembly	12
F85M-1 High-Pressure 'A' Body (Integral Bonnet) Assembly.....	13

1.0 GENERAL

- 1) This manual is intended to provide users with direction and guidance for the maintenance of FLOW SAFE F80M Series safety relief valves. This manual indicates the proper method of valve disassembly, soft goods replacement, and valve reassembly. FLOW SAFE provides this manual as a guideline and reference only. It is not intended to serve as a training manual or manufacturing guide. FLOW SAFE assumes no responsibility for personal or property damage that may occur in conjunction with this manual.

- 2) FLOW SAFE recommends that all valves be placed on a regular maintenance schedule that includes softgoods replacement every three years, but cautions that each customer make their own determination and set their own schedule based upon use and environment. FLOW SAFE believes that when maintenance and reassembly is performed as outlined in this manual there is no safety hazard.

During routine maintenance the internal components of the valve should be inspected for damage or abnormal wear. The valve should also be inspected for excessive corrosion. A corrosion allowance of 0.06" (1.5 mm) is designed into all carbon steel components subject to corrosion. Operating the valve with corrosion exceeding this allowance is not recommended.

Cycling the valve at least once a year is considered to be good practice to verify operation and to confirm that parts are not seized.

- 3) When a new valve leaves FLOW SAFE, it has been manufactured and tested by trained and experienced personnel. When you remove a valve from your system and perform the maintenance tasks that are outlined herein you will need proper training.

Do **not** attempt to accomplish these tasks without adequate training and understanding of the valve operation.

- 4) Any and all stated or implied warranties that are in effect during the purchase of a new FLOW SAFE valve are null and void once the valve has been disassembled by someone other than approved FLOW SAFE personnel.

All repair and resetting of "UV"-stamped safety relief valves should be performed either by FLOW SAFE, Inc., or by a National Board-certified valve repair shop holding a "VR" (Valve Repair) stamp.

- 5) It is highly recommended that all instructions herein be read in full prior to any assembly, disassembly, or operation of this equipment.
- 6) The noted manufacturer's standard lubricants should be used only if compatible with process fluid and application.
- 7) Specific design details described in this document are subject to change without notice.
- 8) Should the need arise for general assistance, contact the FLOW SAFE Sales department at (716) 662-2585 or (800) 828-1036. For more detailed technical assistance, contact the FLOW SAFE Engineering department at (716) 667-3640.

2.0 DESCRIPTION, OPERATION, SERVICE ENVELOPE, INSTALLATION, and STARTUP

2.1 DESCRIPTION / OPERATION

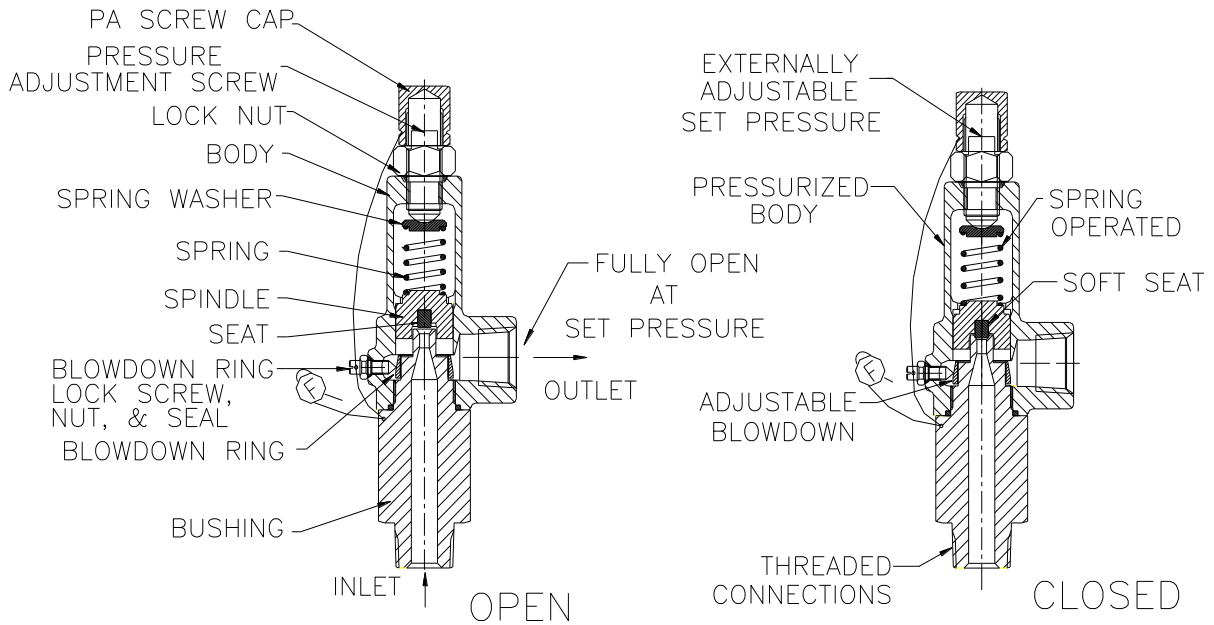

The FLOW SAFE F80M Series safety relief valve is a direct-acting spring-loaded relief valve, suitable for gas service. The Type F84M is plastic-seated and the F85M is elastomer-seated.

Orifice sizes are available in -1,-2,-3, and -4 with set pressures from 15 to 10,313 psig (depending on the orifice size).

Blowdown, up to approx. 20%, is readily controlled by adjusting the blowdown ring. FLOW SAFE valves are typically shipped with 7-10% blowdown, allowing the valve to reseal bubbletight to approximately 90-93% of set point.

2.2 SERVICE ENVELOPE

	F84M				F85M			
ORIFICE	-1	-2	-3	-4	-1	-2	-3	-4
Minimum Set Pressure (psig)	500	15	15	15	90	15	15	15
Maximum Set Pressure (psig)	9944	9944	890	350	10,313	9944	890	350

SEAT MATERIAL	Temp. (°F)	
	Max.	Min. *
F84M		
Vespel	500	-423
PEEK	525	0
Teflon	400	-423
Kel-F	400	-423
F85M		
Buna-N	275	-30
Viton	400	-30
EPR	325	-65
Kalrez	500	0
Polyurethane	225	-60

* Confirm service / application with factory.

2.3 INSTALLATION

Prior to installation, check that the set pressure on the nameplate is as required, and meets the system requirements.

The F80M Series safety relief valve should be installed in the upright position per the figure below, as close as possible to the pressure source, to minimize pressure losses between the system and the valve. This should be in accordance with accepted piping practices, as set forth in the API RP 520, Part II, which recommends that inlet piping pressure losses should not exceed 3% of the set pressure when the valve is flowing.

The valve discharge pipe should be sufficiently large so that backpressure does not exceed 10% of the set pressure when relieving. Higher backpressures may cause the valve to chatter (rapid cycle), or affect capacity.

The F80M Series valves are **unbalanced** against superimposed backpressure, so that the set pressure will change one-for-one with the backpressure. This means that for each 1 psi of backpressure, the set pressure will increase by 1 psi. Refer to Section 4.3 for setting instructions. **Check the valve manufacturer's nameplate(s) to determine if the valve was already set with a correction for backpressure.**

Make sure that the inlet piping/flanges have an opening equal to or greater than the valve's inlet diameter. Make sure that there are no obstructions like gaskets, fittings, etc., in the flow path to restrict the flow or cause chatter. Also, misaligned piping connections may result in leaks or induce stresses in the valve assembly that interfere with good operation. Discharge stacks exposed to the elements should be configured so as to avoid the accumulation of ice and snow.

If a block valve is used below the relief valve, it should be opened before pressurizing the system. This block valve should be locked open during normal system operation.

Use only the wrench flats on the valve inlet bushing, taking care not to make any wrench marks, for tightening and installation. Do not wrench on cast body or bonnet.

2.4 STARTUP

Foreign particles or dirt can damage the valve and make it inoperative. Prior to installation, clean out the piping thoroughly. If the valve is not installed immediately, inlet and outlet connections should be protected and covered.

Pressure can be applied to the valve as system pressure increases, or by opening the block valve (if there is one) after the system has attained operating pressure. Verify the valve seat is leak-tight, in accordance with Section 4.4.

The valve is now ready for service. Inspection and maintenance should be performed on a regular basis, typically once a year, depending on the service conditions.

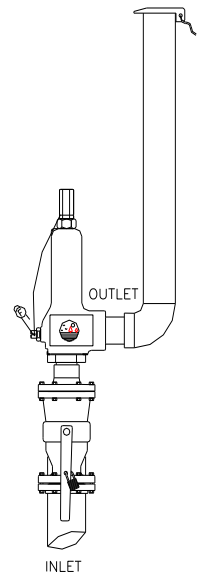

F80 SERIES
TYPICAL INSTALLATION

3.0 VALVE MAINTENANCE

WARNING: It is extremely dangerous to attempt to disassemble any valve while it remains in service with incoming line pressure. Also, improper assembly of the valve may result in leakage or failure of the valve when returned to service.

3.1 DISASSEMBLY OF THE F80M SERIES - 'A' BODY ASSEMBLY

(See Illustrations on pages 11, 12, and 13)

- 1) Remove the valve from service, or adequately and safely block the incoming pressure before disassembling the valve and performing maintenance. **NOTE:** If bushing remains connected to the system piping, then the valve's internal components (spring, washer, spindle) will fall out of the body as it is removed.
- 2) Cut and remove the lockwire.
- 3) Remove the pressure adjusting (PA) screw cap. Measure height of PA screw above body and record value. Loosen the PA screw jam nut. Loosen PA screw until spring load is removed.
- 4) Record gap between bottom of blowdown (BD) ring and bushing shoulder. Then loosen the BD lock nut and lock screw.
- 5) Unscrew and remove the bushing, using wrench flats.
- 6) If valve has a 2-piece body / bonnet (some high-pressure models), unscrew the bonnet from the body. This will expose the spring, spring washer, and lower end of the PA screw.
- 7) Remove the spindle assembly. Remove retainer screw / retainer (as applicable) and seat.
- 8) Remove spring washer and spring.
- 9) Replace softgoods per the instructions in Section 3.2.
 - Replacement parts may be found in the appropriate FLOW SAFE softgoods kit, as listed in Section 5.0 of this manual.

3.2 REASSEMBLY OF THE F80M SERIES - 'A' BODY ASSEMBLY

- 1) Reassembly of these valves is basically the reverse of the disassembly.
NOTE: Care must be taken in the handling of all items, particularly softgoods and nozzle surfaces.
- 2) Apply Neverseez or DuPont Krytox (for oxygen service) to all straight threads.
- 3) Complete seat assembly as follows:
 - a) **F84M:** Insert the plastic seat into the spindle. Apply Loctite or Vibra-tite to retainer screw threads (if applicable). The F84M-1 and F84M-2 (above 890 psig) have a solid, one-piece seat, with no retainer screw. It does have a set screw which should be installed flush with the top of the spindle. The F84M-2 (15-890 psig), -3, and -4 uses a retainer screw to hold the seat in place. Install the seat dry. Tighten retainer screws firmly.
 - b) **F85M:** Insert the O-ring seat into the spindle. To ease seat installation, apply a light coat of Dow Corning 33 or 55 (or Molykote) or Krytox (for oxygen service). The F85M-1, -2, and -3 uses a threaded retainer that enters the top of the spindle. The F85M-4 uses a push-in retainer for the O-ring, except that newer models will incorporate a retainer screw. The push-in retainer must fit tight against the seat, with the tapered end inwards. If fitted with a set screw, install the screw in the top of the spindle. Apply Loctite or Vibra-tite to all threaded retainers and fasteners, and tighten firmly.
- 4) Assemble the spring washer, spring, and spindle assembly into the body .
- 5) Make sure that the spindle moves freely in the guide surface in the body.
- 6) Screw the BD ring onto the bushing, to the same gap as previously recorded.
- 7) Position the bushing seal on the appropriate shoulder of the bushing.
- 8) Screw the bushing / seal / BD ring assembly into the body and tighten.

- 9) For models with 2-piece body / bonnet, check placement of the Teflon crush ring in the bonnet recess near the threads and tighten the bonnet onto the body.
- 10) Screw the PA screw, lock nut, and seal into the top of the body, with screw at previously recorded height.
- 11) Assemble the BD lock screw, lock nut, and seal into the back of the body.

4.0 VALVE TESTING AND ADJUSTMENT

The following tests and adjustments are necessary for gas service valves: set pressure, reseal pressure (blowdown), and seat tightness.

4.1 TEST EQUIPMENT

Where practical, a sufficiently large accumulator or pressure vessel should be used to read and set blowdown. At a minimum a four (4) ft³ vessel is recommended for the -1 orifice to 10,313 psig, -2 orifice to 4072 psig, -3 to 890 psig, and -4 to 350 psig. The supply pipe should have an ID equal to or greater than the valve's, and should be no more than 10" long.

4.2 SETTING / ADJUSTMENT TOLERANCES

<u>Set Pressure:</u>	<u>Set Pressure</u> > 70 psig ≤ 70 psig	<u>Tolerance</u> ± 3% of specified set pressure ± 2 psi
----------------------	---	---

Seat Tightness: There should be ZERO leakage with inlet pressure at or below:

- **0.90 x set pressure**, if set pressure > 50 psig
- **5 psi below set pressure**, if set pressure ≤ 50 psig

4.3 SET PRESSURE and BLOWDOWN ADJUSTMENTS

- NOTES:
- 1) If the set pressure is changed more than ± 5% from the nameplate set pressure, then the spring, spring washer, body, and PA screw may need to be changed. Consult the factory or an authorized FLOW SAFE assembler for the correct parts.
 - 2) If the valve must be set to compensate for constant superimposed backpressure, the set pressure to be used on a test stand ('cold differential test pressure' or CDTP – with zero backpressure) is obtained by subtracting the amount of backpressure from the desired in-service set pressure.

Example:	Desired set point (in service):	100 psig
	Superimposed backpressure:	10 psig
	CDTP (<i>without</i> backpressure):	90 psig

- 1) Remove the PA screw cap (if installed), loosen the PA screw lock nut, and screw the PA screw in (clockwise) most of the way.
- 2) Increase the inlet pressure to the desired level, and then unscrew (counterclockwise) the PA screw until the valve pops. Tighten down the lock nut and retest. Readjust as required.

- 3) To adjust blowdown:
 - a) Be sure the blowdown lock screw and lock nut are loosened.
 - b) Raise or lower the blowdown ring using a screwdriver through the valve outlet. Raising the ring shortens blowdown; lowering the ring lengthens blowdown.
 - c) Re-tighten lock screw and jam nut after adjustments have been made. Only tighten lock screw into blowdown ring knurls enough to prevent ring from turning.
- 4) Install and tighten down the PA screw cap. Test valve at least one more time to verify pop pressure and blowdown.

4.4 SEAT TIGHTNESS

- 1) After any repairs and set pressure adjustments, seat tightness should meet the criteria stated in Section 4.2.
- 2) If the valve leaks after repair refer to the troubleshooting guide on Pages 9 & 10. Check for:
 - Even seating between the spindle and bushing. With the F84M's, you should be able to see a full circular line contact on the bushing surface. Make sure that the seat is installed all the way in the spindle and that the retainer is tight.
 - Foreign particles trapped between the seat and bushing. If found, they may have damaged the seat, requiring that it be replaced.
 - Scratches in the seating area of the bushing.

5.0 SOFTGOODS KITS

Orifice	Kit Part Number	
	F84M	F85M
- 1	F84M-2H-XT	F85M-1-DXT
- 2 (≤ 890)	F84M-2L-XT	F85M-2-DXT
- 2 (> 890)	F84M-2H-XT	F85M-2-DXT
- 3	F84M-3-XT	F85M-3-DXT
- 4	F84M-4-XT	F85M-4-DXT

Code	X = Seat Material		D = Seat Hardness (F85M)	
	F84M	F85M	Code	
T	Teflon	---	5	Soft: ≤ 50 psig
K	PCTFE / Kel-F	---	7	Medium: 51-999 psig
W	Vespel	---	9	Hard: ≥ 1000 psig
P	PEEK	---	0	“Universal”: 1 each of above seats
F	Ekonal-filled Teflon	---		
B	---	Buna-N		
V	---	Viton		
U	---	Polyurethane		
E	---	EPR / EPDM		
Z	---	Kalrez		
C	---	Chemraz		
N	---	Lo-temp nitrile		

Most common seat materials listed; contact Flow Safe for availability of other materials. Seat hardness vs. set pressure listings for F85M are approximate only. “T” in kit part number indicates seals are Teflon.

5.0 SOFTGOODS KITS (cont'd)

SOFTGOODS KIT CONTENTS (See pages 11 through 13)

Qty.	Description
1*	Seat
1	Bushing Seal
1	PA Screw Seal
1	Blowdown Lock Screw Seal

* Additional seats provided with “universal” kit.

6.0 TROUBLESHOOTING GUIDE

Symptom	Possible Cause	Remedy
The valve leaks around the bushing.	Inadequate bushing torque.	Tighten until the bushing bottoms firmly on the body.
	Sealing surface on body or bushing is damaged.	Inspect and polish sealing surfaces.
	Bushing seal is damaged or contaminated.	Remove bushing seal. If damaged, replace with new seal. If contaminated, clean and replace.
The valve leaks through the outlet.	Seat or nozzle seating surface is damaged or contaminated.	Disassemble the valve, remove the spindle, and examine the seat and seating surface under magnification. If damaged, replace with new seat; if contaminated, clean and reinstall.
The valve does not close.	The spindle is stuck.	Disassemble and check for binding. Deburr or replace parts.
The valve opens below the designated set point.	The spring preload is low due to misadjustment, vibration, or other.	Adjust pressure adjusting screw in (clockwise). Ensure PA screw lock nut and cap are tight.
	The seat leaks due to possible damage, allowing early simmer and pop.	Disassemble and inspect seat; replace if damaged.
The valve opens above the designated set point.	The spring preload is high.	Adjust PA screw out (counterclockwise).
	The spindle is stuck or sticking.	Disassemble and check for binding. Deburr or replace parts. Check for a permanent nozzle impression in the O-ring seat (F85M). Replace or contact factory.

6.0 TROUBLESHOOTING GUIDE (cont'd)

Symptom	Possible Cause	Remedy
The valve does not open.	Spindle is stuck closed.	Disassemble the valve and examine the sliding surfaces. If damaged, replace. If contaminated, clean.
	Nozzle stuck to seat.	Disassemble and check seat for permanent impression. Replace O-ring seat (F85M) with harder material.
	The set pressure has not been reached.	Increase inlet pressure. Confirm pressure gage is calibrated.
	Isolation valve is closed.	Open isolation (block) valve.
	There is superimposed backpressure.	Increase pressure until valve pops, or adjust (lower) set pressure (1:1) to compensate for backpressure [See Section 4.3].
The valve chatters or rapid-cycles	The valve is oversized for the application.	Install smaller valve.
	The inlet is choked.	Open the inlet to be equal to or greater than the valve orifice.
	Too much built-up backpressure due to excessive flow, or outlet piping undersized or too long.	At a backpressure equal to approximately 40% of set pressure, chatter / rapid-cycling may start. Reduce backpressure by reducing flow rate or reworking outlet piping (increase size; shorten; reduce number of turns). It is recommended that outlet piping size be equal to or greater than the valve outlet size.

***F84M SERIES (Plastic-Seated) Valve
with "A" Body (Integral Bonnet)
ASSEMBLY ILLUSTRATION***

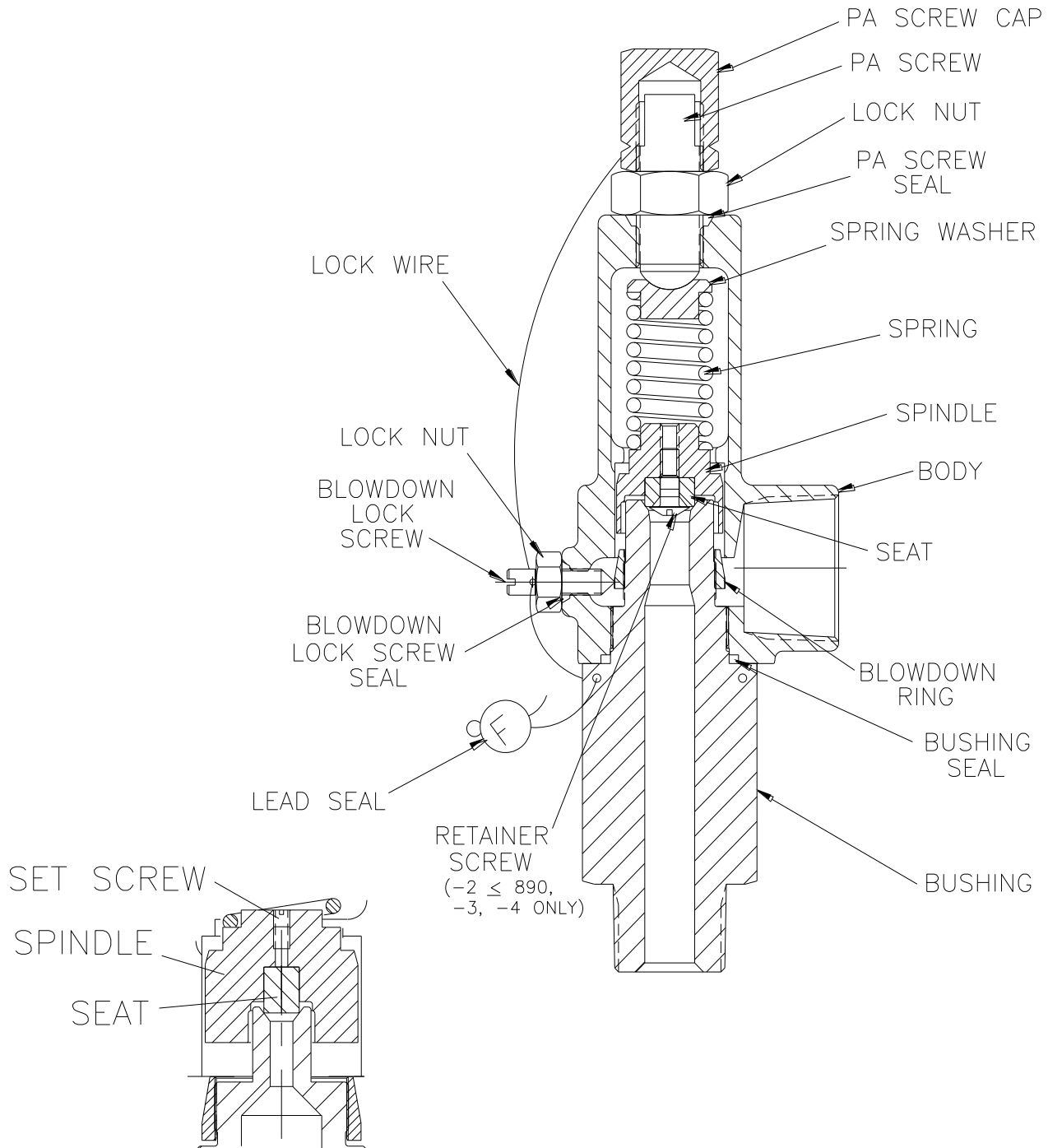

F84M-2 OVER 890 PSIG,
F84M-1

SPINDLE / SEAT DETAIL

***F85M SERIES (Elastomer-Seated) Valve
with "A" Body (Integral Bonnet)
ASSEMBLY ILLUSTRATION***

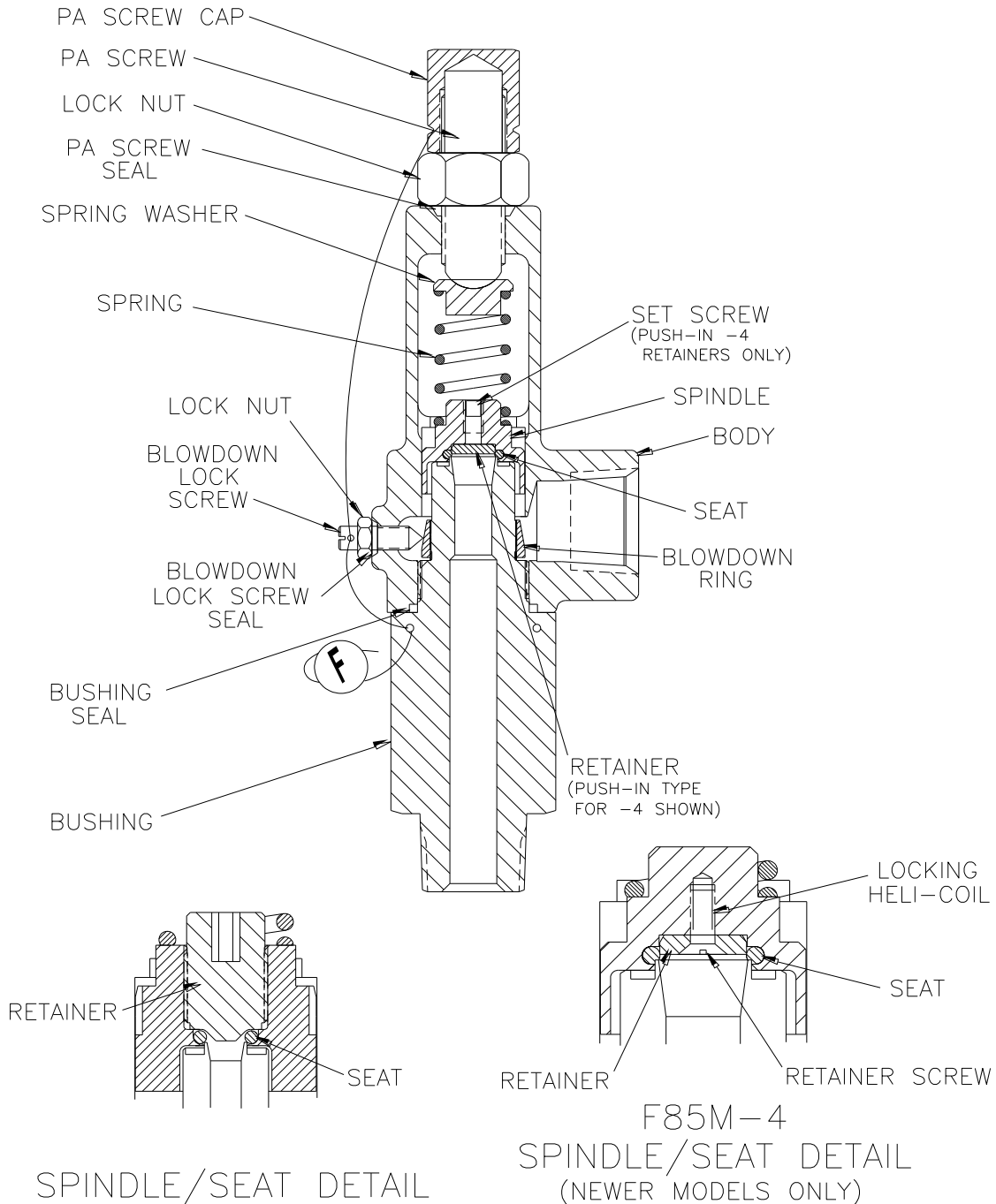

***F85M – 1 (Elastomer-Seated) Valve
with High-Pressure “A” Body (Integral Bonnet)***
ASSEMBLY ILLUSTRATION

