

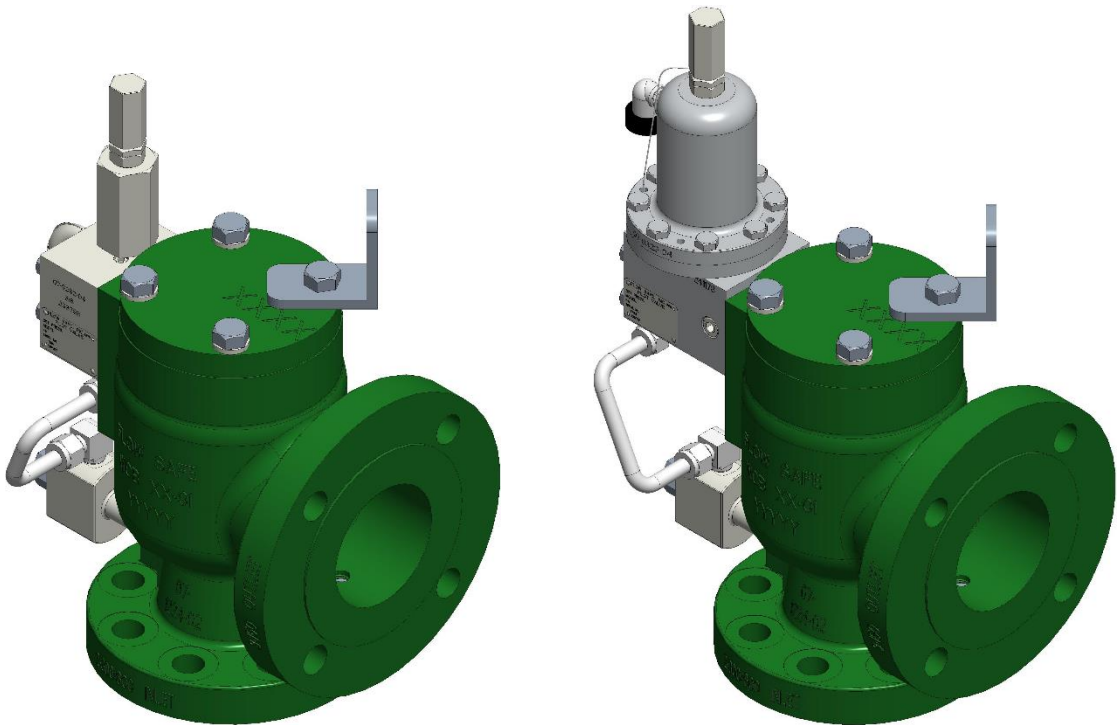

**F7000 / F8000 SERIES  
PILOT-OPERATED  
SAFETY RELIEF VALVE (GAS/LIQUID)**

- F7040: PLASTIC-SEATED, FULL BORE
- F8040: PLASTIC-SEATED, REDUCED BORE
- F7050: ELASTOMER-SEATED, FULL BORE
- F8050: ELASTOMER-SEATED, REDUCED BORE



**INSTALLATION,  
OPERATION, & MAINTENANCE MANUAL**

Revision: W

Date of Issue: June 26, 2024

Approved by:   
Director of Engineering & Quality

**TABLE OF CONTENTS**

<u>Topic</u>	<u>Page</u>
1.0 General .....	3
2.0 Description, Operation, Service Envelope, Installation, & Startup	
2.1 Description / Operation .....	5
2.2 Service Envelope .....	6
2.3 Storage and Handling .....	6
2.4 Installation .....	7
2.5 Remote Sense / Field Test Connection.....	8
2.6 Set Pressure Considerations for Backpressure .....	8
2.7 Startup .....	10
3.0 Main Valve Maintenance	
3.1 Disassembly of the F7000/8000 Series Main Valve .....	10
3.2 Reassembly of the F7000/8000 Series Main Valve.....	13
4.0 Pilot Valve Maintenance	
4.1 F100 Pilot Valve .....	14
4.2 F200 Pilot Valve .....	16
4.3 F300 Pilot Valve, Diaphragm-Style (15 to 500 psig).....	18
4.4 F300 Pilot Valve, Piston-Style (286 to 6000 psig) .....	20
4.5 F500 Pilot Valve .....	23
5.0 Pilot Valve Set Pressure Adjustment	
5.1 Definition / Tolerance.....	26
5.2 Pressure Adjustment / Verification.....	26
5.3 F100 Pilot Valve Adjustment.....	28
5.4 F200 Pilot Valve Adjustment .....	28
5.5 F300 Pilot Valve Adjustment .....	29
5.6 F500 Pilot Valve Adjustment .....	30
5.7 Pilot Auxiliary Setter Adjustment .....	31
6.0 Supplemental Testing and Accessories	
6.1 Testing of the Main Valve Subassembly .....	32
6.2 Final Assembly Testing .....	33
6.3 F300 Pilot Valve Proportional Band Adjustment.....	33
6.4 Inservice Testing with the Field Test Connection .....	34
6.5 Harguard Clean Pilot Supply Tank.....	36
7.0 Troubleshooting Guide .....	37
8.0 Softgoods Kits	
8.1 Main Valve Softgoods .....	38
8.2 Pilot Valve Softgoods .....	39

## 1.0 GENERAL

1) This manual is intended to provide users with direction and guidance for the maintenance of FLOW SAFE F7000 / 8000 Series safety relief valves. This manual indicates the proper method of valve disassembly, soft goods replacement, and valve reassembly. FLOW SAFE provides this manual as a guideline and reference only. It is not intended to serve as a training manual or manufacturing guide. FLOW SAFE assumes no responsibility for personal or property damage that may occur in conjunction with this manual.

2) FLOW SAFE believes that when maintenance and reassembly is performed as outlined in this manual there is no safety hazard. FLOW SAFE recommends that all valves be placed on a regular maintenance schedule that includes the routine replacement of softgoods. FLOW SAFE recommends softgoods replacement every three years but cautions that each customer make their own determination and set their own schedule based upon use and environment.

During routine maintenance the internal components of the valve should be inspected for damage or abnormal wear. The valve should also be inspected for excessive corrosion. A corrosion allowance of 0.06" (1.5 mm) is designed into all carbon steel components subject to corrosion. Operating the valve with corrosion exceeding this allowance is not recommended.

Cycling the valve at least once a year is considered to be good practice to verify operation and confirm parts are not seized.

3) When a new valve leaves FLOW SAFE, it has been manufactured and tested by trained and experienced personnel. When you remove a valve from your system and perform the maintenance tasks that are outlined herein you will need proper training.

Do **not** attempt to accomplish these tasks without adequate training and understanding of the valve operation.

4) Any and all stated or implied warranties that are in effect during the purchase of a new FLOW SAFE valve are null and void once the valve has been disassembled by someone other than approved FLOW SAFE personnel.

All repair and resetting of "UV"-stamped safety relief valves should be performed either by FLOW SAFE, Inc., or by a National Board-certified valve repair shop holding a "VR" (Valve Repair) or "T/O" (Test Only) stamp.

5) It is highly recommended that all instructions, especially WARNING and CAUTION statements, herein be read in full prior to any assembly, disassembly, or operation of this equipment.

6) The noted manufacturer's standard lubricants should be used only if compatible with process fluid and application.

7) Specific design details described in this document are subject to change without notice.

8) Should the need arise for general assistance, contact the FLOW SAFE Sales or Service department at (716) 662-2585 or (800) 828-1036 in Orchard Park NY. For more detailed technical assistance, contact the FLOW SAFE Engineering department at (716) 662-2585.

**2.0 DESCRIPTION, OPERATION, SERVICE ENVELOPE, INSTALLATION, and STARTUP**

**Conventional / Tubed Pilot:**

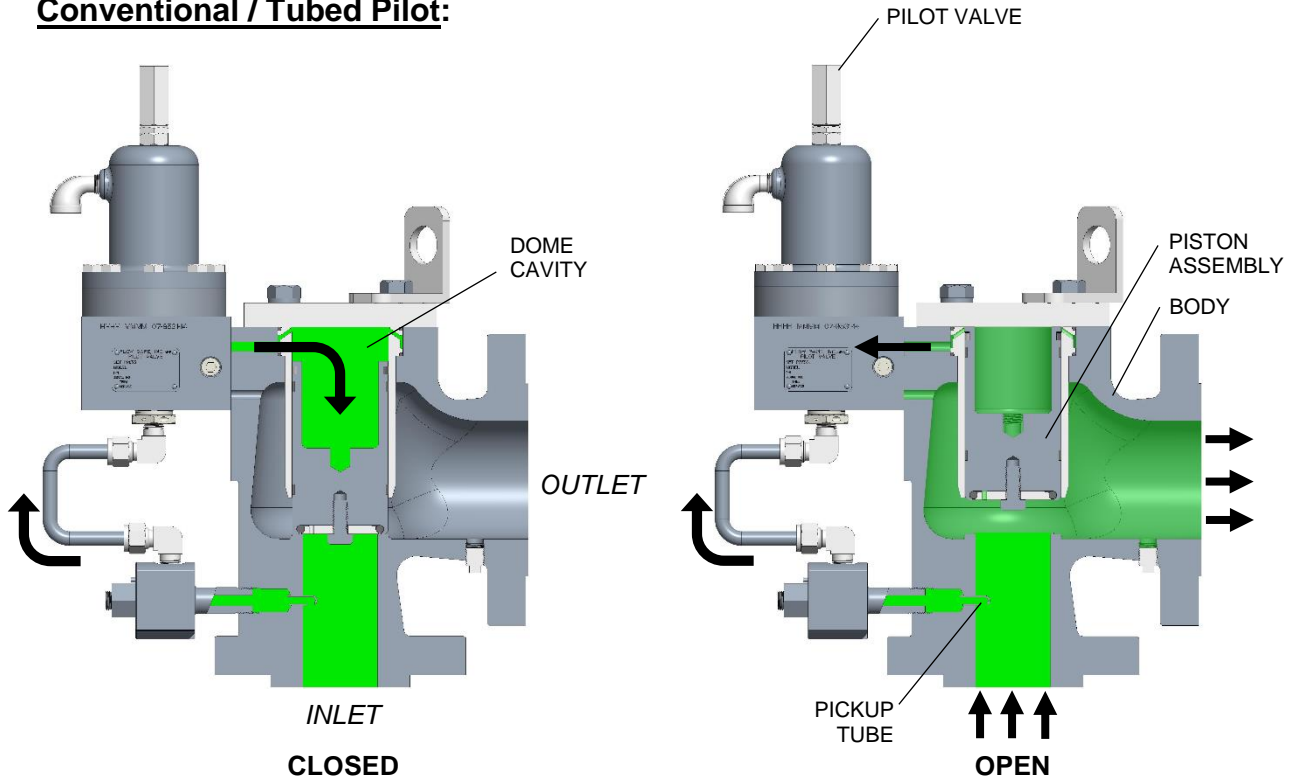

**Integral Module (IM) Construction (legacy):**

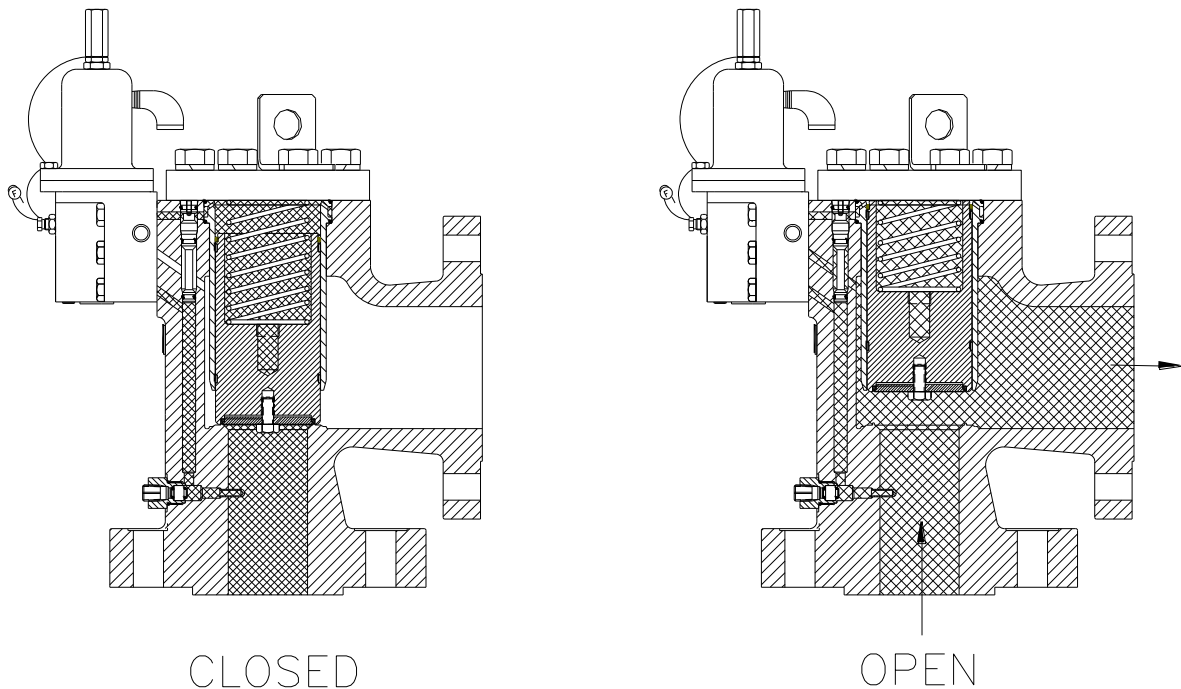

## 2.1 DESCRIPTION / OPERATION

FLOW SAFE F7000 / 8000 Series pilot-operated relief valves have been furnished to industry with a standard externally tubed pilot valve or, in nominal sizes up through 2 x 3 with an inlet rating of ANSI 900 or above, with Integral Module (IM) construction. IM construction eliminates external tubing by relying on porting within the main valve body for pressure actuation. Unless identified otherwise in this manual, installation, startup, operation, and maintenance is the same for both styles of F7000 / 8000 Series valves. Contact the factory for current availability of IM construction.

Referring to the figures on Page 4, system pressure is routed from below the valve through the pilot valve to the "dome" cavity of the main valve. This dome pressure, acting on a piston area larger than the seat area, creates a net positive downward force ( $F = P \times A$ ) which holds the main valve piston closed.

At the designated set pressure, the pilot valve reduces dome pressure, allowing system pressure to lift the main valve piston. With the modulating-style Model F100, F300, or F500 pilot, dome pressure is vented proportionally to demand at set pressure. With the snap-acting Model F200 pilot, dome pressure is completely vented at set pressure. Once system pressure is relieved, the pilot valve closes the main valve at set pressure for the F100, F300, or F500, or at the preset blowdown pressure for the F200. Once the dome is again pressurized up to system pressure, the main valve piston will be held in its closed position.

The F200 snap-acting pilot valve blowdown is adjustable from 3% to 20% of set pressure, and is normally factory-set at 7 to 10% unless otherwise specified. The F100, F300, and F500 modulating pilot valves provide zero blowdown; i.e., the main valve opens in proportion to demand and closes at the set pressure.

Set pressure for a valve with a pilot auxiliary setter is the pilot nameplate set pressure plus the auxiliary setter nameplate differential pressure. Auxiliary setters are designated for use with specific valves by means of matching serial numbers. If a valve has more than one auxiliary setter, different interface diameters prevent them from being installed in the wrong order.

The F7000 / 8000 uses either an elastomeric or plastic seat on the piston to achieve bubble-tight seating. A dynamic piston seal prevents any leakage from the dome to the discharge. Guide rings on the piston eliminate metal-to-metal contact with the liner and help to provide smooth and consistent operation. Elastomeric and plastic seals seal the main valve and pilot valves.

The orifice size may be easily selected by choosing a full-bore inlet nozzle (F7000 Series), or by converting to a reduced-size orifice (F8000 Series) through the attachment of FLOW SAFE's unique *annular-flow plug* to the bottom of the piston assembly. This plug reduces the effective flow area of the valve by directing the fluid between the plug O.D. and the nozzle I.D.

Flow Safe model numbering system is shown below for easy identification of the F7000 or F8000 product. This is designated on the main valve body's nameplate for TYPE.

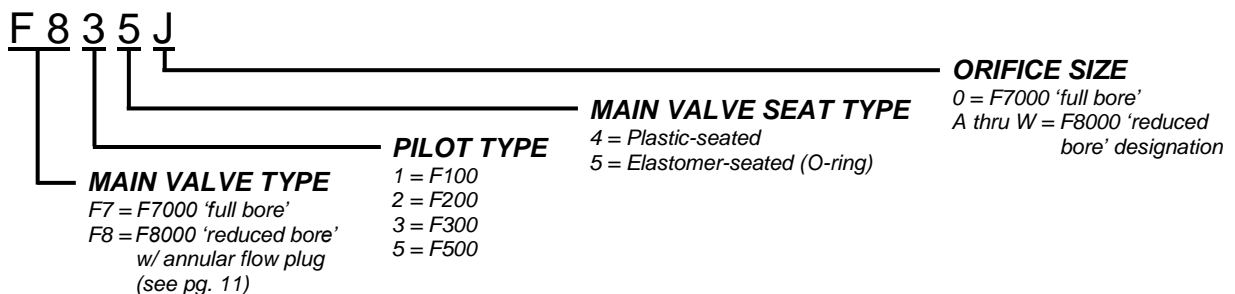

# INSTALLATION, OPERATION, & MAINTENANCE MANUAL



**TITLE: F7000 / 8000 Series  
Pilot-Operated Safety Relief Valve**

**Rev. W  
Page 6 of 41**

## 2.2 SERVICE ENVELOPE

SEAT MATERIAL	PROCESS TEMP., °F (°C)		SET PRESSURE, psig (barg)	
	Min. <sup>1</sup>	Max.	Min.	Max. <sup>2</sup>
Buna-N	-30 (-34)	275 (135)	15 (1)	6000 (413)
Viton®	-30 (-34)	400 (204)	15 (1)	6000 (413)
Polyurethane	-65 (-54)	225 (107)	15 (1)	6000 (413)
EPR	-65 (-54)	325 (163)	15 (1)	6000 (413)
Teflon®	-423 (-252)	400 (204)	15 (1)	1000 (69)
Kel-F	-423 (-252)	400 (204)	1000 (69)	3000 (207)
PEEK	0 (-18)	525 (273)	3000 (207)	6000 (413)
PI / PAI / Vespel®	-423 (-252)	500 (260)	3000 (207)	6000 (413)

<sup>1</sup> Confirm low-temperature applications with factory. Some O-ring seated valve configurations have had cryogenic qualification testing performed down to -261°F (-163°C).

<sup>2</sup> Pilot valve MAWP's: 740 psig (F100); 6000 psig (F200, F300, & F500)

## 2.3 STORAGE AND HANDLING

### A. STORAGE

Prior to installation, Flow Safe pressure relief valve assemblies and parts should be stored in a clean, dry environment if possible. Inlet and outlet connections should remain covered until the item is ready for installation.

For outside storage, protection from the elements is recommended particularly if plugs and flange covers are not weather-tight. Exposed carbon steel surfaces should remain coated with a suitable rust inhibitor until the assembly is ready for installation.

Even though elastomers and lubricants in the relief valve typically have a long shelf life and can be used in environments down to -40 °F/°C, operability of the main piston should be checked before placing the valve in service after extended storage. See Section 2.4.

### B. HANDLING AND LIFTING

Flange facings and other gasket sealing surfaces shall be isolated from contact with other hard objects through the use of cardboard or other soft materials. Placing flanged surfaces directly on wooden skids should be avoided due to possible contact with nails.

Valve assemblies shall be lifted only from installed lifting lugs or brackets, provided on all valves 2" x 3" and larger or with heavy flanges or accessories. Smaller valves can be carried by hand (by holding the main body and not tubing or other fittings). When two lifting lugs are provided, generally on valve assemblies 4" x 6" and larger, the load must be balanced by use of a sling (chain, web, or rope). See diagram below. All hooks, slings, and other lifting devices shall be rated for the valve assembly weight as identified by project drawings, shipping documents, or scales used at receiving.

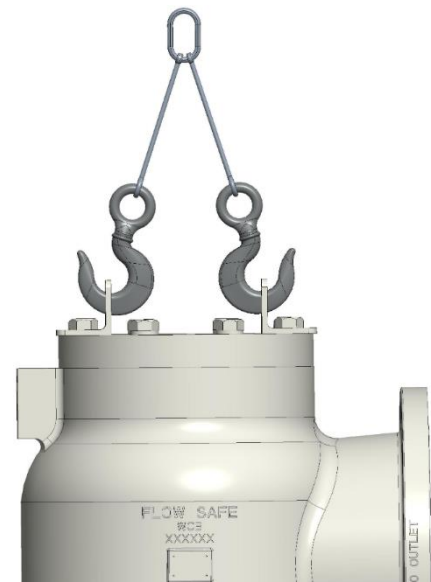

**TYPICAL LIFTING ARRANGEMENT**  
LIFTING BRACKETS  
ROTATED 60-90° IN THIS VIEW



## 2.4 INSTALLATION

**CAUTION:** Use lifting brackets provided on the cap for lifting the entire valve assembly.

Prior to installation, check that the set pressure on the nameplate is as required, and meets the system requirements. Lifting and handling should follow the instructions in Section 2.3.

If the valve has been in storage for a significant length of time, verify that the main piston can still freely move by pushing on it manually through the valve inlet. If it does not return to the closed position, it may be necessary to seat the piston using a pressure source connected to the field test, pilot, or main valve cap.

The F7000 or F8000 Series safety relief valve should be installed in the upright position per the figure below, in accordance with accepted piping practices. Proper gaskets, lubricants and torques, as specified in field procedures, must be used during assembly of bolted joints. Unless inlet pressure will be remotely sensed (see Section 2.5), inlet piping pressure losses should not exceed 3% of the set pressure when the valve is flowing [Ref. API 520 Part II]. Discharge piping should be configured so as to avoid accumulation of ice and snow. Severe misalignments of inlet and outlet piping to the valve's flanges should be avoided. Adequate bracing of the inlet and outlet discharge piping must be provided to withstand the thrust force created when the valve discharges.

If a block valve is used below the relief valve, it should be opened before pressurizing the system. This block valve should be locked open during normal system operation.

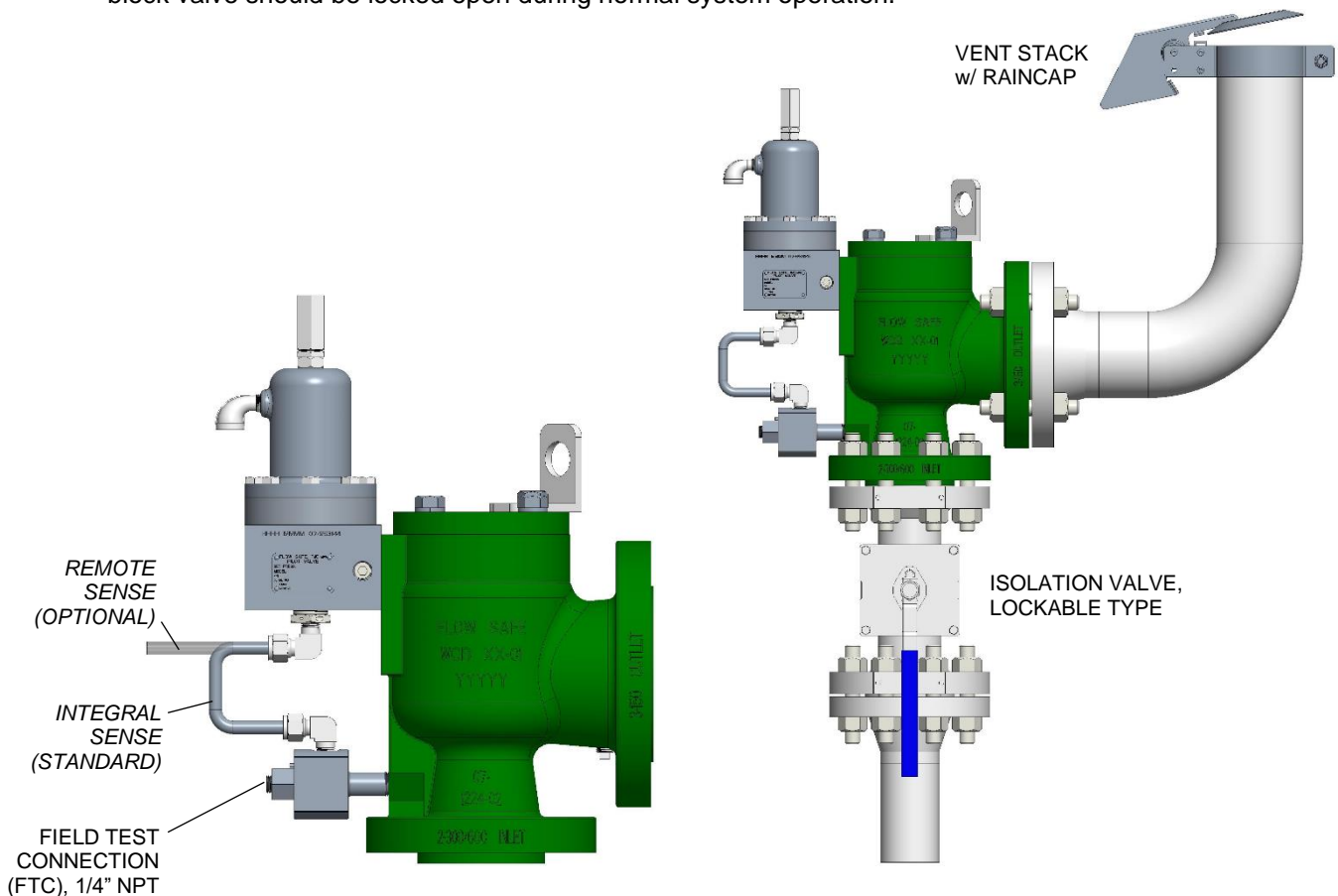

## 2.5 REMOTE SENSE / FIELD TEST CONNECTION (FTC)

### A. PURPOSE

As shown in the figure on Page 9, the F7000 / 8000 remote sense connection feeds system pressure directly into the pilot valve inlet line from the pressure vessel, bypassing the main relief valve inlet. Remote sense is recommended for installations where there is excessive pressure loss (exceeding 3%) in the inlet line between the vessel and an open, flowing safety relief valve.

The field test connection provides means to apply test pressure to the pilot valve to test its set pressure. Operation is covered in detail in Section 6.4.

### B. REMOTE SENSE INSTALLATION AND OPERATION

**CAUTION:** Extreme care must be taken and full compliance with procedures should be used when servicing or testing a safety relief valve used in gas or incompressible fluid service. These service media may be volatile or under high pressure and can be very dangerous.

- 1) Select a remote sense connection point at a pressure tap on the vessel or other selected location on the system. It is recommended to use a tap location that will not experience significant velocity flow to the relief valve inlet line should the relief valve open.
- 2) Route tubing or pipe (1/2" minimum recommended) from the pressure tap to the connection at the rear of the main valve. Minimize any bends or extensive lengths. Tighten all connections thoroughly.
- 3) To feed system pressure to the pilot valve, open the manual valve at the connection to the pilot inlet tubing. As main valve inlet pressure just below the seat lags pressure buildup in the vessel, pressure in the remote sense tubing should override valve inlet pressure and have a direct flow path to the pilot. The check valve or manual valve provided prevents back-flow into the relief valve inlet line. The manual valve should remain closed when remote-sensing pressure. On older valves where the remote sense line is connected to the field test assembly, the shuttle piston inside the field test will function as a check valve to ensure pressure is routed to the pilot valve.

## 2.6 SET PRESSURE CONSIDERATIONS FOR BACK PRESSURE

In general, backpressure has no effect on the flow capacity of the FLOW SAFE F7000 / 8000 Series of pilot-operated valves as long as a critical flow condition exists. The critical flow pressure ratio for a particular gas may be estimated by equations given in API 520 Part I, or by contacting FLOW SAFE Engineering.

Set pressures are not affected by backpressure when using the F300 or F500 pilot valves as they are balanced against such pressure, or by the F200 as it is normally vented to atmosphere. Caution should be used if the F200 vent is routed to the main valve discharge or other pressurized vessel, as the set pressure and blowdown may be affected.

Backpressure greater than the system inlet pressure normally would cause the main valve piston to open. Because the F200, F300, and F500 pilot valves are equipped with backflow preventers as standard features this cannot occur on the F7000 / 8000 valves. The backpressure is routed to the main valve piston dome, keeping the valve closed and bubble-tight.



# INSTALLATION, OPERATION, & MAINTENANCE MANUAL



**TITLE: F7000 / 8000 Series Pilot-Operated Safety Relief Valve**

**Rev. W  
Page 9 of 41**

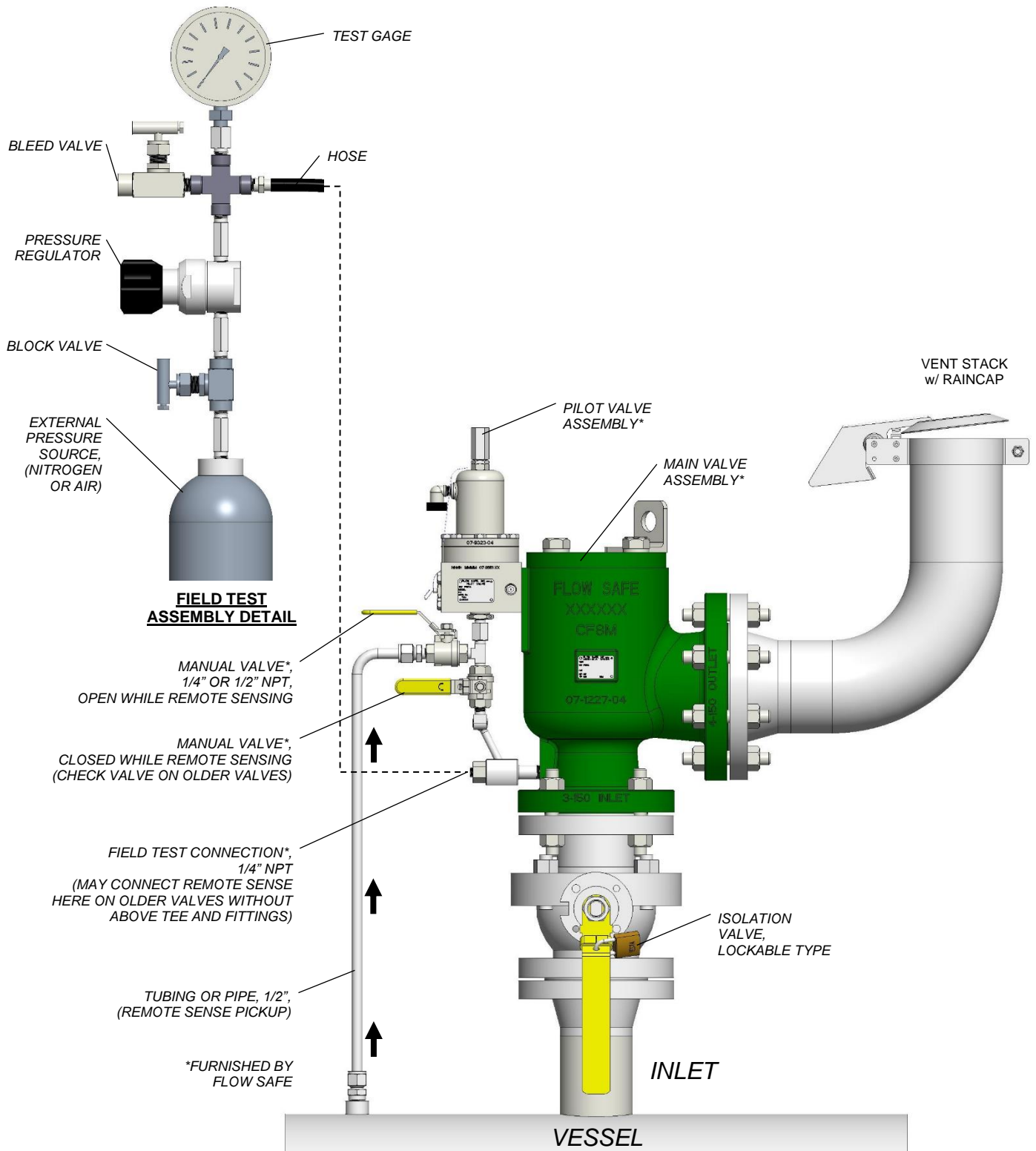

## **F7000 / F8000 SERIES RECOMMENDED INSTALLATION FOR REMOTE SENSE / FIELD TESTING**

## 2.7 STARTUP

Foreign particles or dirt can damage the valve and make it inoperative. Prior to installation, clean piping thoroughly. If valve is not installed immediately, inlet / outlet connections should be protected and covered.

Pressure can be applied to the valve as system pressure increases, or by opening the block valve (if there is one) after the system has attained operating pressure. Pressure should flow through the pilot valve into the dome cavity of the main valve and seat the piston. The valve may briefly vent to the exhaust before the dome is fully pressurized. A dome spring installed in newer valves is intended to help keep the piston seated with less-than-full dome pressure. Verify that the valve seat is leak-tight, in accordance with Section 6.1.

The valve is now ready for service. Inspection and maintenance should be performed on a regular basis, typically once a year, depending on the service conditions.

## 3.0 MAIN VALVE MAINTENANCE

**WARNING:** Improper assembly of the main valve or pilot may result in leakage and/or failure of the valve assembly.

### 3.1 DISASSEMBLY OF THE F7000 / 8000 SERIES MAIN VALVE (See Pages 11 and 12)

**WARNING:** It is extremely dangerous to attempt to disassemble any valve while it remains in service with incoming line pressure. Due to the possibility of pressure being trapped in the main valve dome region (above main piston) with valve out of service, pilot mounting bolts and cap bolts should be loosened very slowly at first when performing steps (2) and (3) below.

- 1) Remove the valve from service, or safely block the incoming pressure before disassembling the valve and performing maintenance.
- 2) If necessary, remove the pilot valve and interconnecting tubing. See Section 4.0 for pilot valve maintenance. The field test connection (FTC) may be removed by unscrewing the NPT connection to the main valve. Older FTC bodies have a straight thread, lock nut, and Teflon seal. See main valve assembly figures on Pages 11-12.
- 3) Remove the bolts, lockwashers, and any lifting brackets that hold the valve cap in place.
- 4) With the cap removed, remove the dome spring if present, and top liner seal.

**NOTE:** A dome spring has been furnished in many newer valves, except at very low pressures, to provide additional closing force on the main valve piston. At startup, this feature helps minimize venting of the piston during initial pressurization.

- 5) Carefully reach into the valve and remove the piston assembly. Newer pistons may have an interior threaded hole in which a cap bolt can be inserted to use for lifting. Note that the liner may come out with the piston assembly. Care must be taken during this removal because any damage might result in a sealing problem after the valve is reassembled.
- 6) The liner may then be removed; again, care must be taken not to damage the liner. Do not attempt to pry or force the liner out as you may score the surface and cause a sealing problem.
- 7) Remove the retainer bolt, annular flow plug [if F8000 Series], and seat retainer. Larger F8000 flow plugs may be fitted with a spring pin that locks its position on the piston and retainer. The spring pin should remain in the piston due to an interference fit.
- 8) If the valve is IM construction, remove the pressure isolation spool at the top rear of the body using a 1/4-20UNC bolt.
- 9) Replace softgoods in the piston, liner, and (if applicable) pressure isolation spool per the instructions in Section 3.2. Replacement soft goods are listed in Section 8.0 of this manual.

# INSTALLATION, OPERATION, & MAINTENANCE MANUAL



**TITLE:** F7000 / 8000 Series  
Pilot-Operated Safety Relief Valve

**Rev. W**  
**Page 11 of 41**

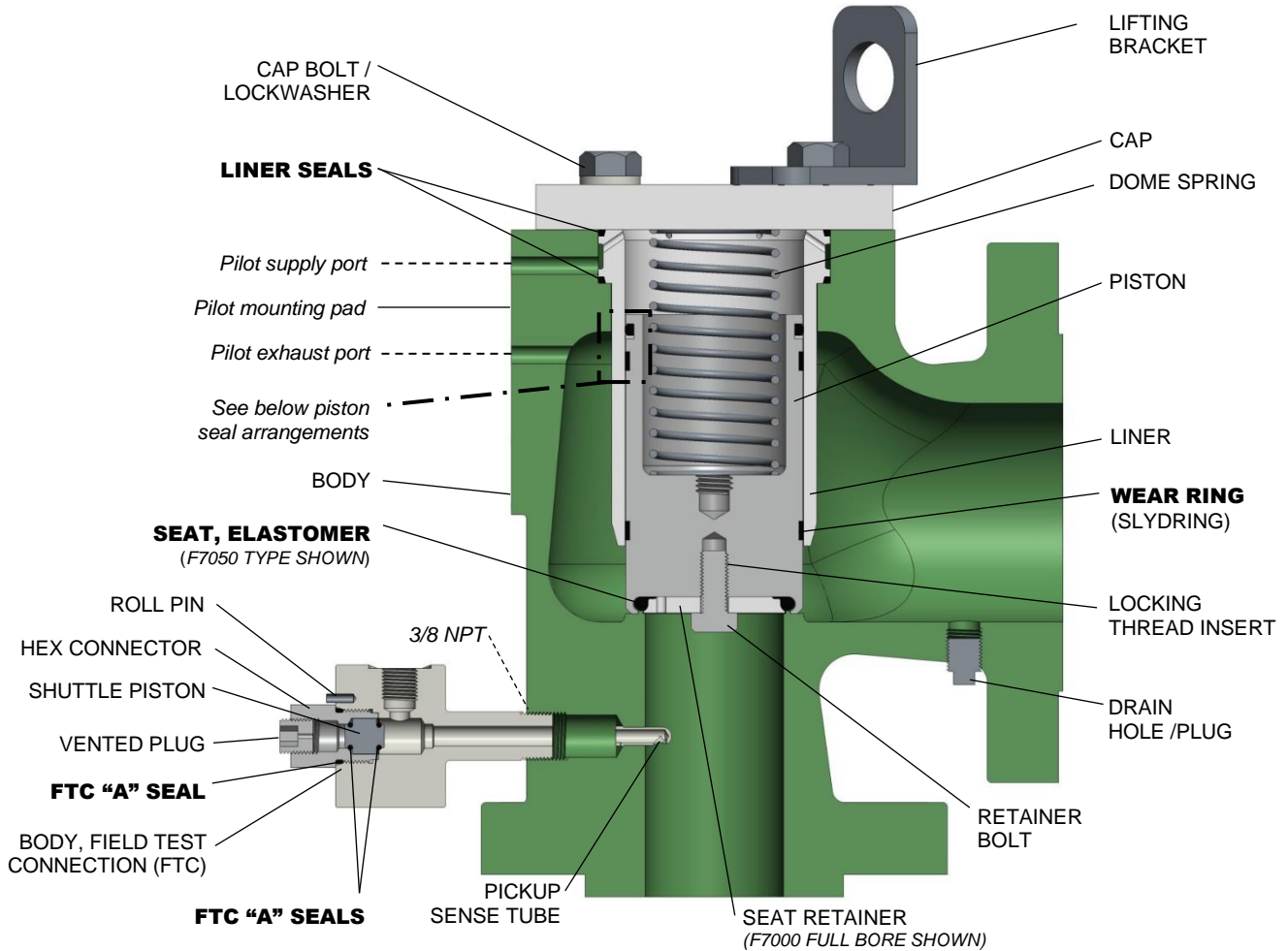

## F7040/F8040 (PLASTIC SEATED)

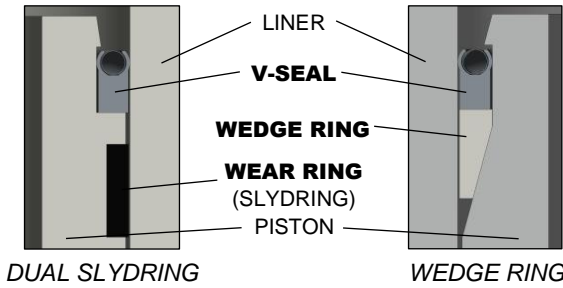

## F7050/F8050 (ELASTOMER SEATED)

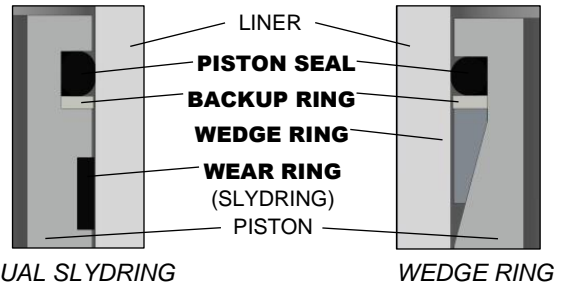

### PISTON SEAL ARRANGEMENTS

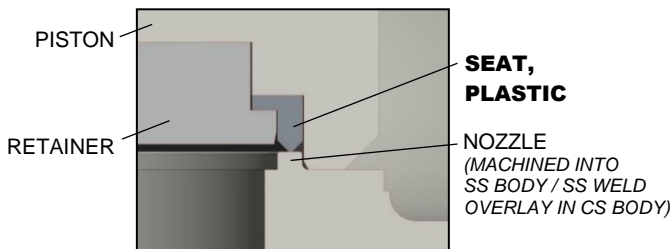

### F7040/F8040 PLASTIC SEAT

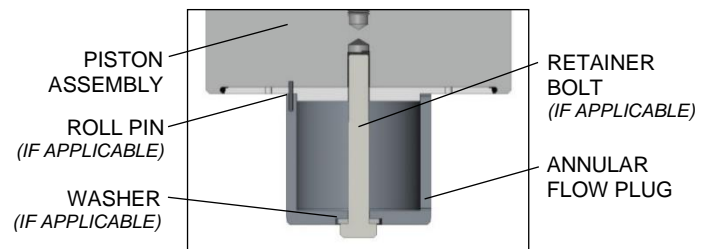

### F8000 ANNULAR FLOW PLUG

# INSTALLATION, OPERATION, & MAINTENANCE MANUAL



**TITLE: F7000 / 8000 Series  
Pilot-Operated Safety Relief Valve**

**Rev. W  
Page 12 of 41**

## Straight-thread style FTC (legacy):

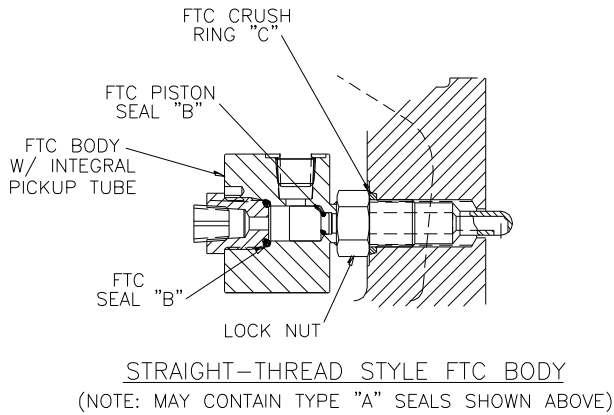

## Piston seal (legacy):

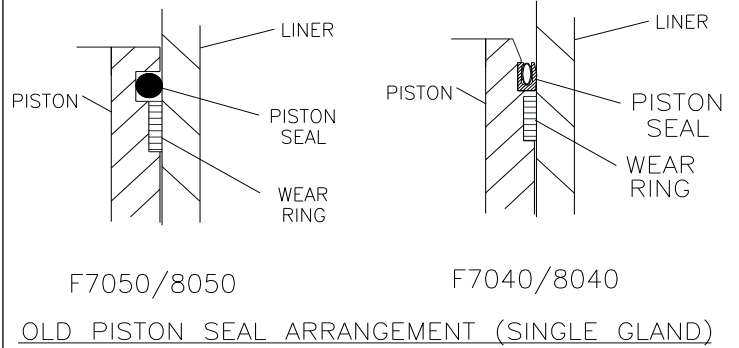

## Integral Module (IM) Construction (legacy):

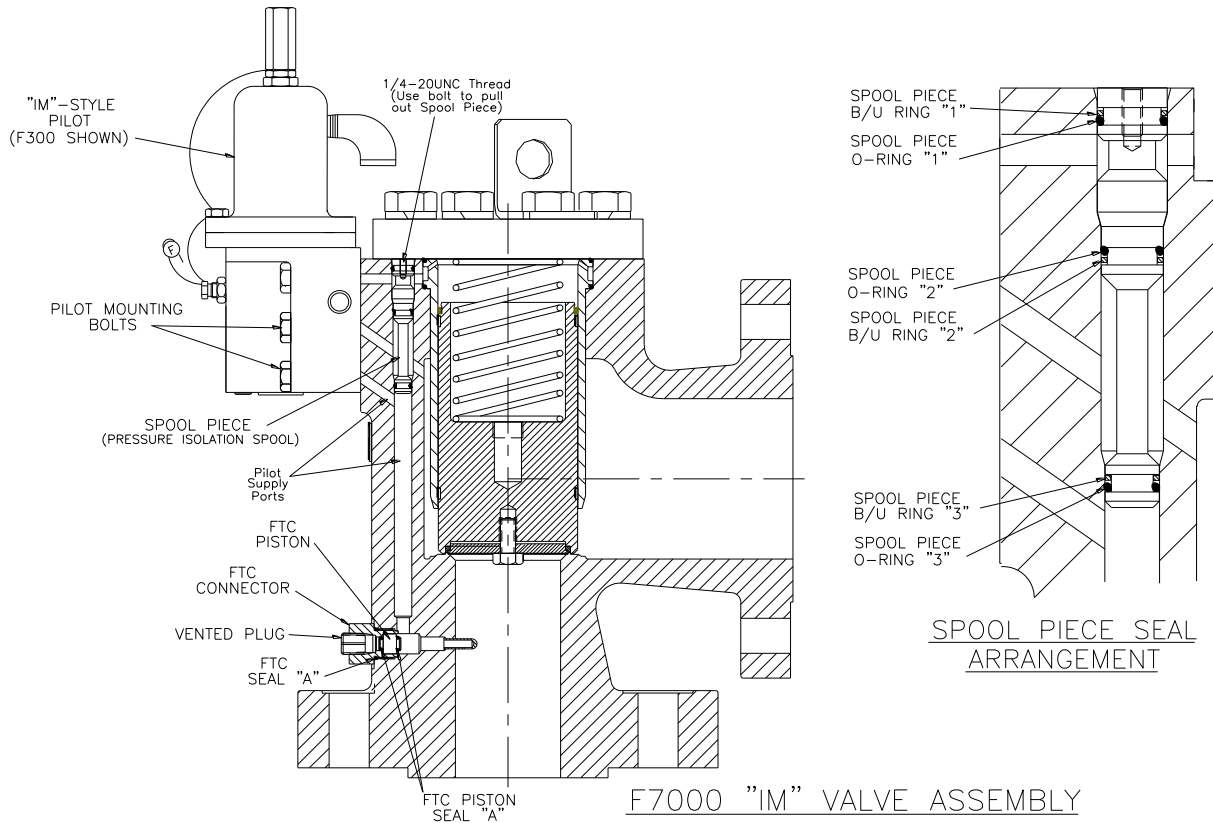

**3.2 REASSEMBLY OF THE F7000 / 8000 SERIES MAIN VALVE**

- 1) Reassembly of these valves is basically the reverse of disassembly. Care must be taken in the handling of all items, particularly sealing surfaces and softgoods. All parts should be clean and free of any debris or contaminants.
- 2) Reinstall the liner and liner seals into the body. Do not nick or excessively stretch the liner seal O-rings. The bottom O-ring may be carefully set in its sealing area in the body before the liner is inserted, or it may be fitted onto the liner and, if necessary, held in place with a suitable lubricant (e.g., Dow Corning Molykote 33). Lightly press top seal into place in its groove, such that it is evenly spread around the liner circumference and will not be pinched by the cap.
- 3) Insert the O-ring or plastic seat into the bottom of the piston, using care to position the seat completely within the piston cavity. NOTE that any scratches, gouges, or particles on the seat may result in a sealing problem. Carefully position retainer plate over the seat. For the F8000 series, position the annular flow plug over the retainer and, if applicable, the spring pin in the piston. Apply Loctite or Vibra-tite to the retainer bolt. Insert bolt and tighten to: 4-5 ft-lbs (1/4" bolt); 12-14 ft-lbs (3/8"); 34-37 ft-lbs (1/2"); 55-60 ft-lbs (3/4"). **IMPORTANT:** Retainer bolt must meet firm resistance against locking Heli-Coil in piston. Replace Heli-Coil if worn or damaged.
- 4) Install piston seal. Dow Corning Molykote 33 or equivalent may be lightly applied to the O-ring style (F7050 or F8050 model only). If the valve has a vacuum setpoint based on piston weight, Lubriplate 105 or other suitable slippery lubricant is recommended for the piston seal. Do not lubricate the Teflon V-seal used in the F7040/F8040 model.
- 5) Fit the wear / wedge ring(s) in their proper groove in the piston assembly. The flat wear ring(s) do not require any lubricant. If a wedge ring is used, it should be installed with a coating of Desco 600 (or equal) grease on the outside face. While holding the rings (especially free ends) in place, lower the piston assembly into liner. It is critically important that this installation result in even seating of the soft seat onto the raised nozzle lip in valve body.
- 6) If the valve is IM construction, reinstall the spool piece with new softgoods. Apply a light coat of lubricant (Molykote or equivalent) to the seals.
- 7) If the valve is fitted with a dome spring, reinstall the spring in the piston.
- 8) After checking placement of the top liner seal [see Step (2)], the valve cap can be positioned on top of the body.
- 9) The cap bolts, with washers, can then be reinserted and torqued to the values listed below.

<u>Main Valve Size</u>	<u>Cap Bolt Size</u>	<u>Torque (ft-lbs) – CS (B7) / SS</u>
1x2, 1-1/2x3 & 2x3 (thru 1500#), 4x6 (thru 300#)	1/2-13UNC *	50 / 25
1-1/2x3 and 2x3 (2500#)	5/8-11UNC *	65 / 45
3x4, 4x6 (600-1500#), 6x8, 8x10, 10x12, 12x16	3/4-10UNC *	120 / 80

\* UNF thread on older valves

- 10) If removed previously, reinstall the pilot valve and tubing. The pilot mounting bolts should be treated with Loctite or Vibra-tite, if available, and firmly tightened.
- 11) The main valve is now completely assembled, and should be tested per Section 6.0 before being returned to service.

## **4.0 PILOT VALVE MAINTENANCE**

### **4.1 F100 PILOT VALVE** (See Illustration on Page 15)

#### **A. F100 Disassembly**

**CAUTION:** It is extremely dangerous to attempt to disassemble any valve while it remains in service with incoming line pressure.

- 1) Remove the pilot valve from the main valve, or safely block the incoming pressure before disassembling the valve and performing maintenance.
- 2) Unscrew the pressure adjustment screw cap from the pressure adjustment screw. Loosen the lock nut.
- 3) Loosen but do not remove the pressure adjustment screw from the pilot valve bonnet.
- 4) Remove the bolts (also nuts and lockwashers on older bodies) that hold the valve body and bonnet in place. Separate the bonnet from the body. Remove the spring and two spring washers.
- 5) With a wrench on the diaphragm lock nut and screwdriver in the top of the spindle, loosen the lock nut and remove it from the spindle.
- 6) Remove inner/outer spacer(s) from the top of the valve body. Remove the diaphragm from the spindle by unscrewing it counter-clockwise.
- 7) Turn the pilot valve body over and remove the nozzle and spindle. Unscrew the retainer screw from the spindle. Remove the retainer and seat.
- 8) Replacement soft goods are listed in Section 8.0 of this manual.

#### **B. F100 Assembly**

**NOTE:** Exercise care in handling softgoods, nozzles, and other sealing surfaces.

- 1) Confirm pressure setting and associated parts required.
- 2) Place the valve body in a vise.
- 3) Apply Loctite 248 to retainer screw. Place the spindle, with the retainer and seat screwed into place into the valve body, and assemble the nozzle (with seal and O-ring) into the body. Dow Corning Molykote 33 or equivalent may be used to lubricate O-rings.
- 4) Carefully assemble the diaphragm to the top of the spindle by slowly turning the diaphragm clockwise on the spindle threads until it bottoms on the shoulder. Make sure that there are no tears or rips in the diaphragm material.
- 5) Apply small amount of Loctite 268 to diaphragm lock nut threads. Assemble inner/outer spacer(s) and lock nut to the spindle. With a wrench on the nut, and a screwdriver in the top of the spindle, tighten the parts together. Apply a small drop of Loctite to the nut threads. Make sure that the spacers are centered to the extent possible.
- 6) Assemble the spring and spring washers atop the spindle.
- 7) Assemble the gasket (only if using a Teflon diaphragm) and then the bonnet over the spring and spring washers onto the top of the diaphragm / body.
- 8) Apply Loctite 248 to 4 bonnet bolts and insert the bolts through the four holes in the body and bonnet (washers and nuts also for older bodies).
- 9) Tighten the bolts to a torque of 5 - 6 ft.-lbs.
- 10) Insert the pressure adjustment screw into the top of the bonnet and install the lock nut.
- 11) Attach the pressure adjustment screw cap to the top of the pressure adjustment screw, but do not tighten down.
- 12) Insert the inlet screen into the INLET port in the body.
- 13) Attach the vent / bug screen in the bonnet so that it faces away from the main valve mounting surface. Face seals should then be positioned on the mounting face.
- 14) The pilot valve is now completely assembled and ready to be set per Section 5.0.



# INSTALLATION, OPERATION, & MAINTENANCE MANUAL



TITLE: F7000 / 8000 Series  
Pilot-Operated Safety Relief Valve

Rev. W  
Page 15 of 41

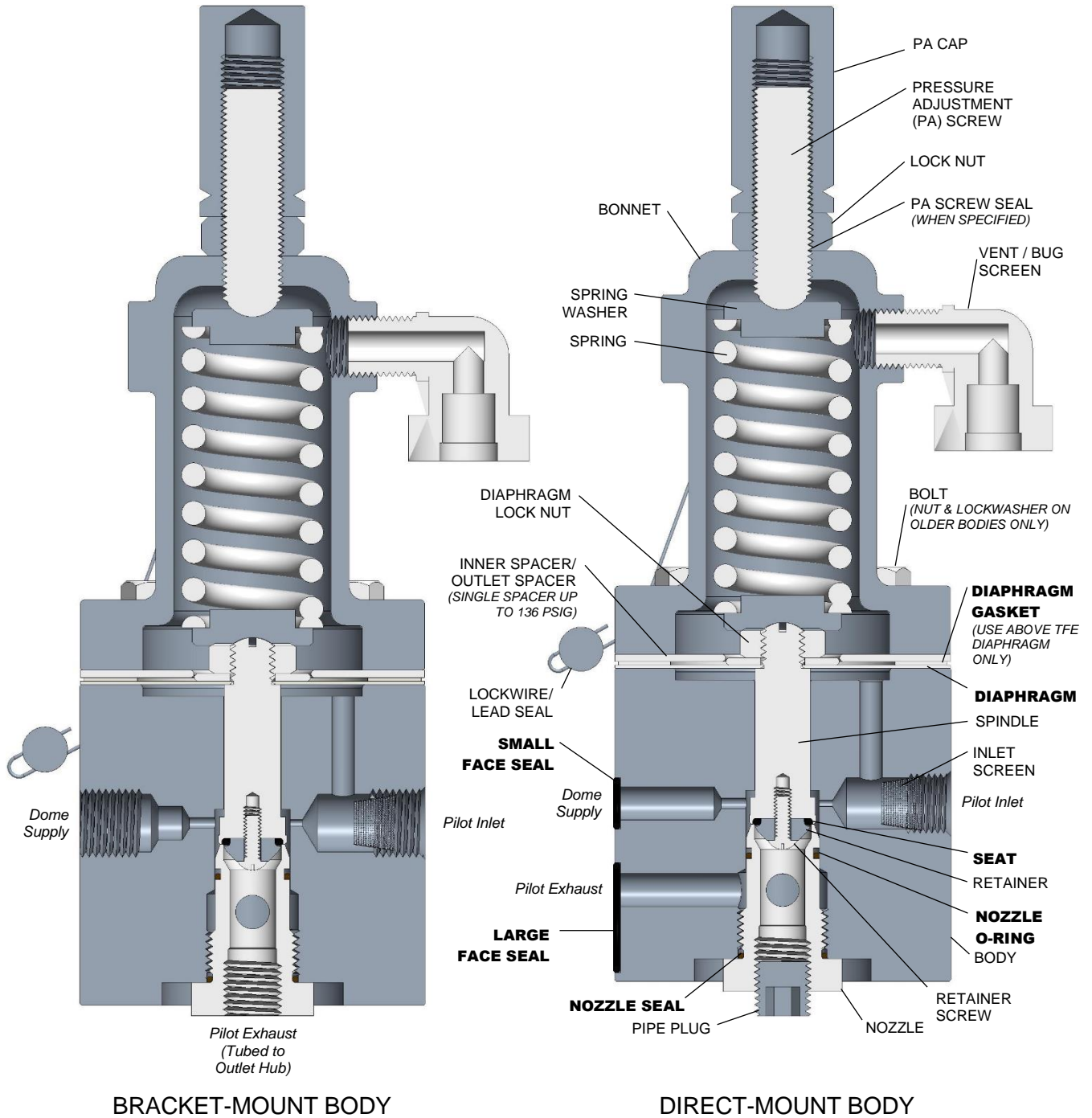

## F100 PILOT VALVE ASSEMBLY, HIGH PRESSURE 5 – 740 PSIG

## **4.2 F200 PILOT VALVE** (See Illustrations on Page 17)

### **A. F200 Disassembly**

**CAUTION:** It is extremely dangerous to attempt to disassemble any valve while it remains in service with incoming line pressure.

- 1) Remove the pilot valve from the main valve, or safely block the incoming pressure before disassembling the valve and performing maintenance.
- 2) Unscrew the pressure adjustment (PA) screw cap from the PA screw. Loosen the lock nut.
- 3) Loosen, but do not remove the pressure adjustment screw from the bonnet.
- 4) Further disassembly can proceed in the reverse order from the below assembly instructions.
- 5) Replacement soft goods are listed in Section 8.0 of this manual.

### **B. F200 Assembly**

**NOTE:** Exercise care in handling softgoods, nozzles, and other sealing surfaces.

- 1) Confirm pressure setting and associated parts required.
- 2) Place the valve body in a vise.
- 3) Place the seat onto the seating surface of the upper spindle.
- 4) After applying Vibra-tite to upper spindle threads, install upper spindle w/seat into upper piston and tighten. Check to ensure that seat is correctly retained and is not misaligned.
- 5) Lightly lubricate the upper nozzle seal with Dow Corning Molykote 33 or equivalent, and install it into the groove on the upper nozzle.
- 6) Place upper spindle / piston assembly onto upper nozzle and check for adequate seat squeeze.
- 7) Install upper spindle / piston / nozzle assembly into the valve body using a 5/16 wrench and tighten. Check to ensure that the upper spindle / piston moves freely in the valve body.
- 8) Install inlet screen into the bushing or body (for 'IM' style).
- 9) Install seat onto the lower retainer.
- 10) Insert lower retainer / seat into the lower piston.
- 11) Insert lower retainer / piston assembly into the bushing.
- 12) Install the lower nozzle into the bushing and tighten.
- 13) Assemble jam nut and bushing seal onto the lower nozzle / bushing assembly. For IM construction, also install 'IM' bushing O-ring onto the OD of the bushing.
- 14) Place the spacer into the opening of the lower nozzle / bushing assembly.
- 15) Install spacer / lower nozzle / bushing assembly into valve body, ensuring that the spacer enters the opening of the previously installed upper piston / spindle / nozzle assembly.
- 16) Install pipe plugs into valve body as shown in the illustration. For optional manual blowdown, replace 3/8" NPT plug with reducing bushing and 1/4" NPT ball valve.
- 17) Assemble spring and spring washers onto the upper spindle top which protrudes through the valve body.
- 18) Install bonnet over spring / washers and onto valve body and tighten. For the high-pressure model, also install the bonnet cap and set screw.
- 19) Assemble lock nut onto the pressure adjustment (PA) screw and then install the PA screw into the bonnet.
- 20) Attach the cap to the PA screw but do not tighten.
- 21) Install backflow preventer (BFP) O-ring onto BFP piston.
- 22) Insert BFP piston assembly into valve body.
- 23) Install BFP body and face seals into valve body.
- 24) The pilot valve is now completely assembled and ready to be set per Section 5.0.
- 25) If applicable, install lockwire and lead seal. Repair tag may be attached to wire.

# INSTALLATION, OPERATION, & MAINTENANCE MANUAL



**TITLE:** F7000 / 8000 Series  
Pilot-Operated Safety Relief Valve

Rev. W  
Page 17 of 41

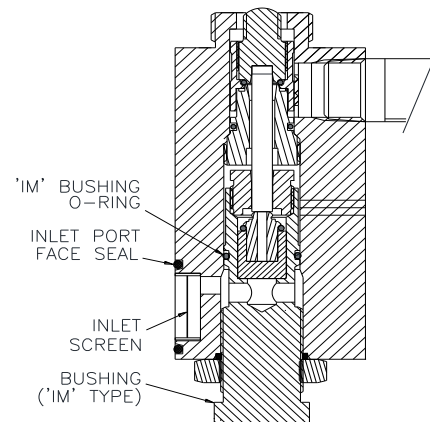
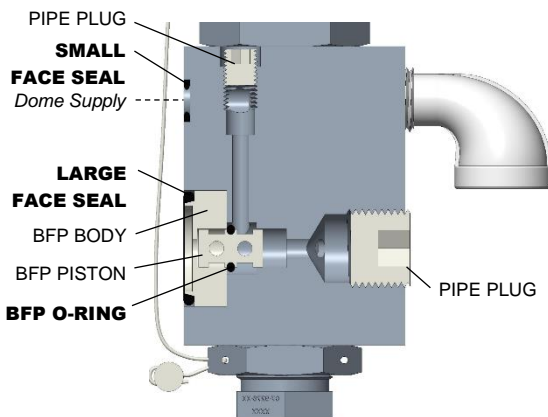
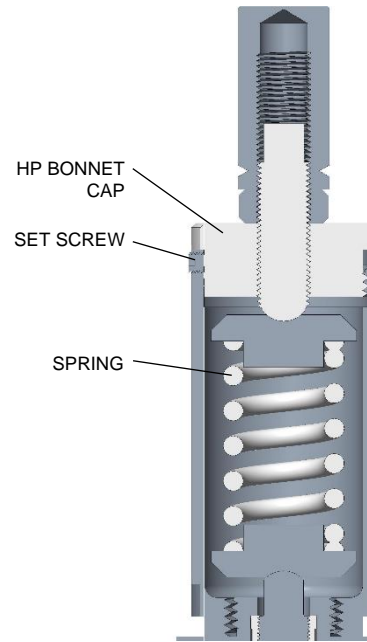
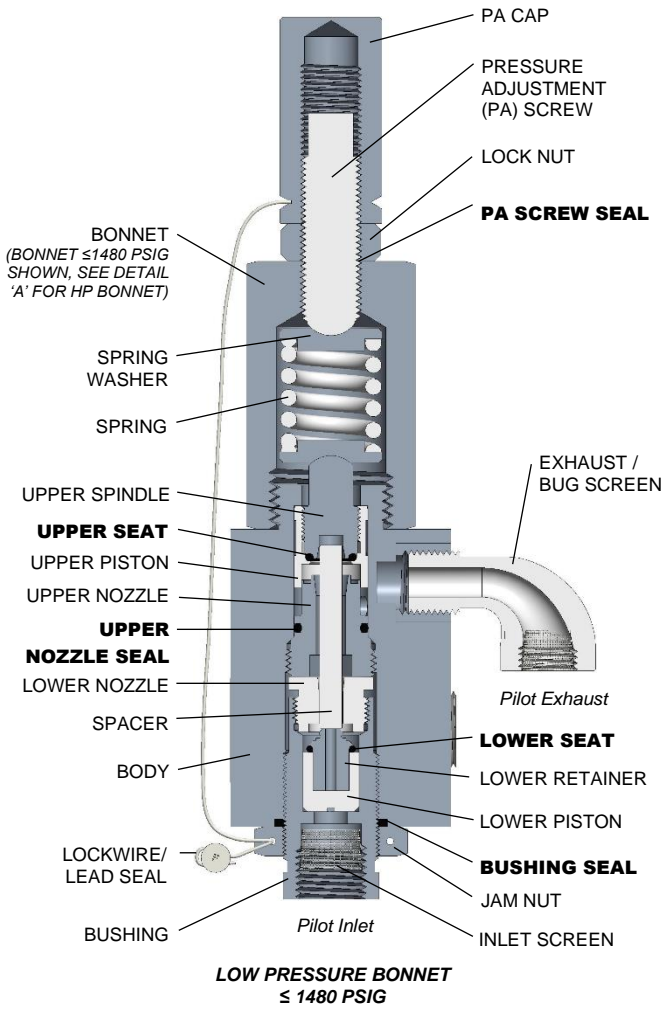

## F200 PILOT VALVE ASSEMBLY 15 – 6,000 PSIG

# INSTALLATION, OPERATION, & MAINTENANCE MANUAL



TITLE: F7000 / 8000 Series  
Pilot-Operated Safety Relief Valve

Rev. W  
Page 18 of 41

## 4.3 F300 PILOT VALVE, DIAPHRAGM-STYLE (15-500 psig) (See Illustration below)

### A. F300 (Diaphragm-style) Disassembly

**CAUTION:** It is extremely dangerous to attempt to disassemble any valve while it remains in service with incoming line pressure.

- 1) Remove the pilot valve from the main valve, or safely block the incoming pressure before disassembling the valve and performing maintenance.
- 2) Unscrew the pressure adjustment (PA) screw cap from the PA screw. Loosen the lock nut.
- 3) Loosen, but do not remove the PA screw from the bonnet.
- 4) Further disassembly can proceed in the reverse order from the assembly instructions on Page 19.
- 5) Replacement soft goods are listed in Section 8.0 of this manual.

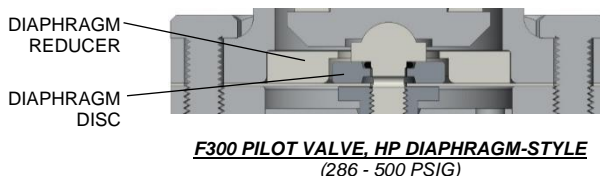
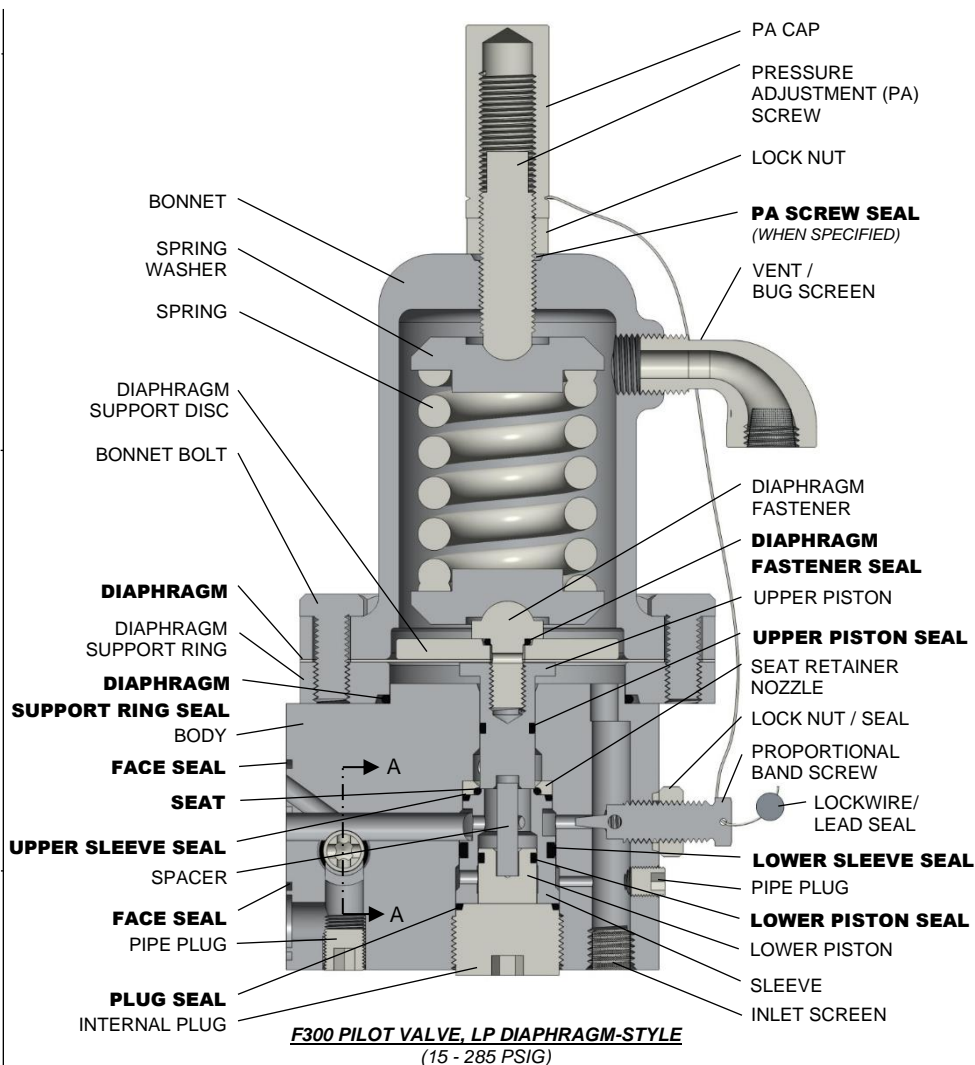
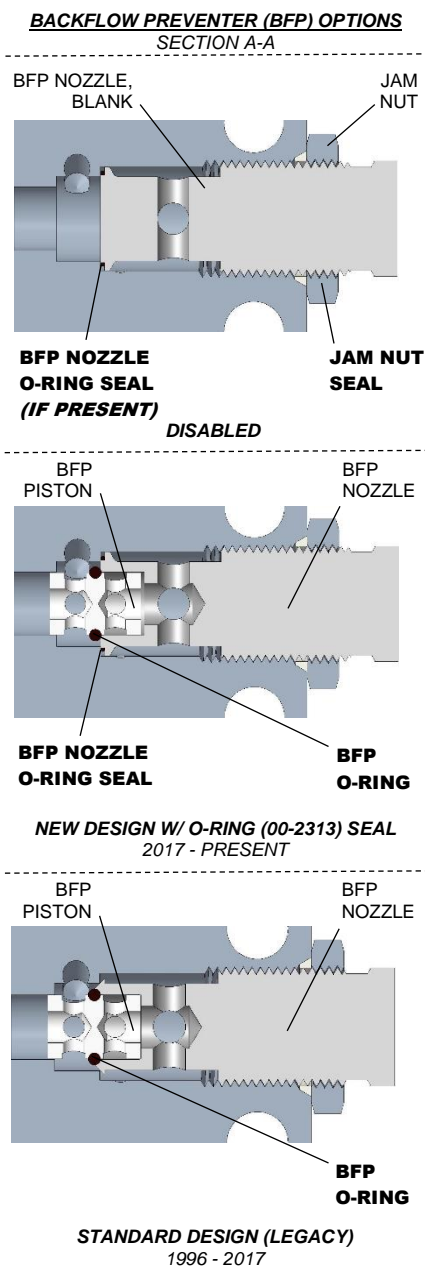



## **B. F300 (Diaphragm-style) Assembly**

NOTE: Exercise care in handling softgoods, nozzles, and other sealing surfaces.

- 1) Confirm pressure setting and associated parts required.
- 2) Place the valve body in a vise.
- 3) Install pipe plugs into the valve body.
- 4) Install backflow preventer (BFP) O-ring onto BFP piston.
- 5) Assemble BFP jam nut and seal onto BFP nozzle. For modified nozzle design with 00-2313-xx O-ring on leading edge, install O-ring with light coat of lubricant to hold it in place in its gland.
- 6) Place BFP piston with O-ring into end of nozzle. Install BFP assembly into valve body until very tight (conventional chamfered nozzle) or snug (O-ring-tipped nozzle), then tighten BFP jam nut so as to crush the Teflon seal.
- 7) Assemble lock nut and proportional band screw seal onto proportional band screw.
- 8) Install the proportional band screw assembly into the valve body. Screw in CW until the screw bottoms in the body, and then back out CCW 1-1/2 turns (also see Section 6.3 for band screw adjustment). Tighten lock nut.
- 9) Insert inlet screen into valve body.
- 10) Lightly lubricate lower sleeve seal with Dow Corning Molykote 33 or equivalent, and install into groove of sleeve.
- 11) Lightly lubricate upper sleeve seal and place onto the top of the sleeve. Install the seat into the bottom side of the seat retainer nozzle, and assemble on top of the sleeve.
- 12) Lightly lubricate lower piston seal and install into groove of lower piston. Insert the lower piston assembly into the sleeve until they are flush at the bottom. Then install the seat retainer sleeve lower piston subassembly into the valve body until it bottoms. Check to ensure that all seals and O-rings are correctly aligned. The PA screw cap can be used to verify proper fitup. Place the cap on a flat surface; then lower the pilot body with subassembly onto the cap and push down until the assembly snaps into place and is solid.
- 13) Place the plug seal onto bottom of the sleeve. Screw the internal plug into the body until tight. Make sure that this plug is very tight.
- 14) From the top, install spacer pin into the recess in lower piston previously installed.
- 15) Lightly lubricate upper piston seal and install into groove of upper piston.
- 16) Place the diaphragm fastener seal onto the diaphragm fastener.
- 17) For the low pressure diaphragm style pilots (15-285 psig) place the diaphragm support disc and diaphragm onto the diaphragm fastener. For the high pressure diaphragm style pilots (286-500 psig) place the diaphragm disc and diaphragm onto the diaphragm fastener. Apply a small amount of Loctite onto the fastener threads. Make sure that the center counterbore area on the diaphragm support disc faces the O-ring seal. NOTE: Older diaphragm support discs have an O-ring counterbore on both sides.
- 18) Install diaphragm assembly into the upper piston and tighten firmly.
- 19) Assemble diaphragm support ring seal and diaphragm support ring onto valve body.
- 20) Insert upper piston / diaphragm assembly into valve body. Ensure that the spacer pin fits into the recess in the bottom of the upper piston. Align the holes between the diaphragm and the support ring. For the high pressure diaphragm style pilots (286-500 psig) place the diaphragm area reducer onto the diaphragm.
- 21) Assemble spring and spring washers onto diaphragm fastener.
- 22) Install bonnet over spring and spring washers and onto diaphragm support ring. Align bonnet, diaphragm, and support ring so that the unthreaded through-hole in the support ring lines up with the bolt holes in the valve body, and the two small through-holes in the bonnet, diaphragm, and support ring align and clear the valve body. The vent / bug screen opening (1/4 FNPT) in the bonnet should face away from the main valve mounting surface.
- 23) Install the four long bolts through the bonnet / diaphragm / support ring into the valve body, and tighten.
- 24) Install the four short bolts through the bonnet / diaphragm into the diaphragm support ring, and tighten.

- 25) Assemble the pressure adjustment (PA) screw and lock nut into the top of the bonnet.
- 26) Attach the cap to the PA screw, but do not tighten.
- 27) Install vent / bug screen into bonnet, ensuring that the male NPT end does not contact the spring. Install the inlet screen into the body.
- 28) Mount the face seals onto the external mounting face of the body.
- 29) The pilot valve is now completely assembled and ready to be set per Section 5.0.
- 30) If applicable, install lockwire and lead seal between PA screw cap, bonnet, and proportional band screw. Repair tag may be attached to wire.

#### **4.4 F300 PILOT VALVE, PISTON-STYLE (501 to 6000 psig)** (See Illustrations below and on Page 21)

##### **A. F300 (Piston-style) Disassembly**

**CAUTION:** It is extremely dangerous to attempt to disassemble any valve while it remains in service with incoming line pressure.

- 1) Remove the pilot valve from the main valve, or safely block the incoming pressure before disassembling the valve and performing maintenance.
- 2) Unscrew the pressure adjustment (PA) screw cap from the PA screw. Loosen the lock nut.
- 3) Loosen, but do not remove the PA screw from the bonnet.
- 4) Further disassembly can proceed in the reverse order from the assembly instructions on Page 22.
- 5) Replacement soft goods are listed in Section 8.0 of this manual.

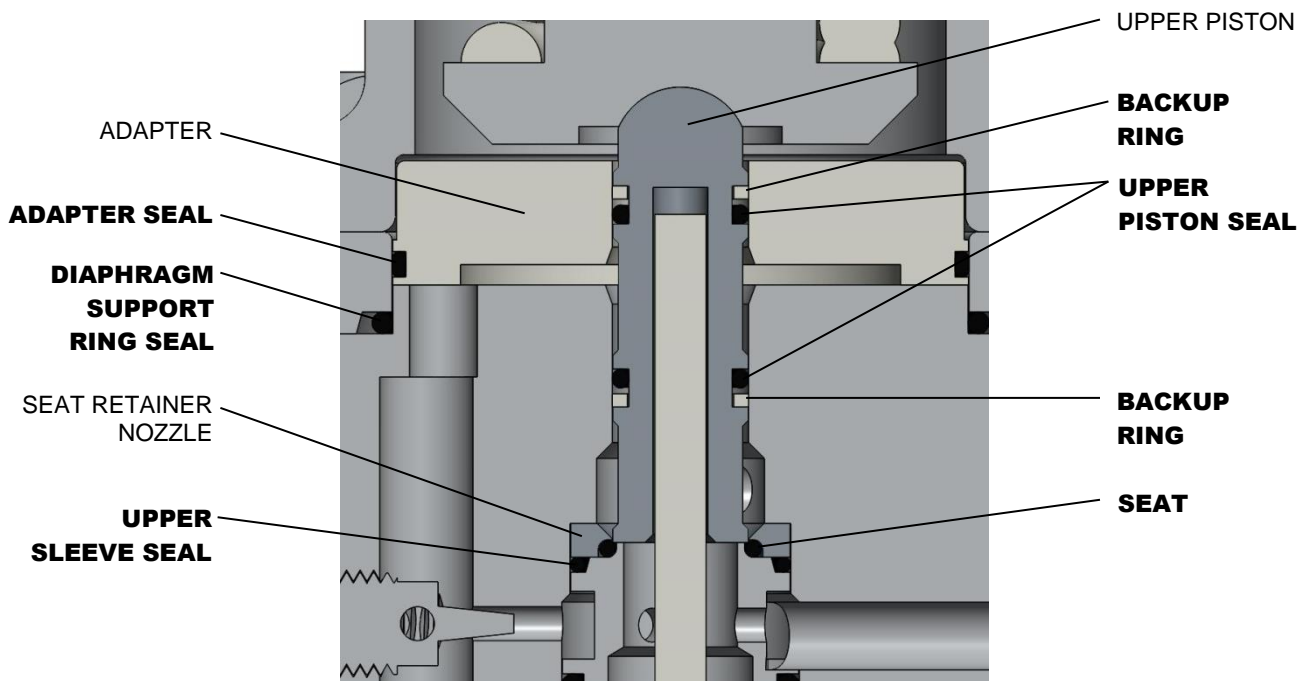

**F300 PILOT VALVE, HP PISTON-STYLE**  
(501 - 6,000 PSIG)  
SEE FULL ASSEMBLY ON PAGE 22

See Section A-A on Page 18 for Backflow Preventer (BFP) details



# INSTALLATION, OPERATION, & MAINTENANCE MANUAL



TITLE: F7000 / 8000 Series  
Pilot-Operated Safety Relief Valve

Rev. W  
Page 21 of 41

## LP Piston Style, 286-1480 psig (legacy):

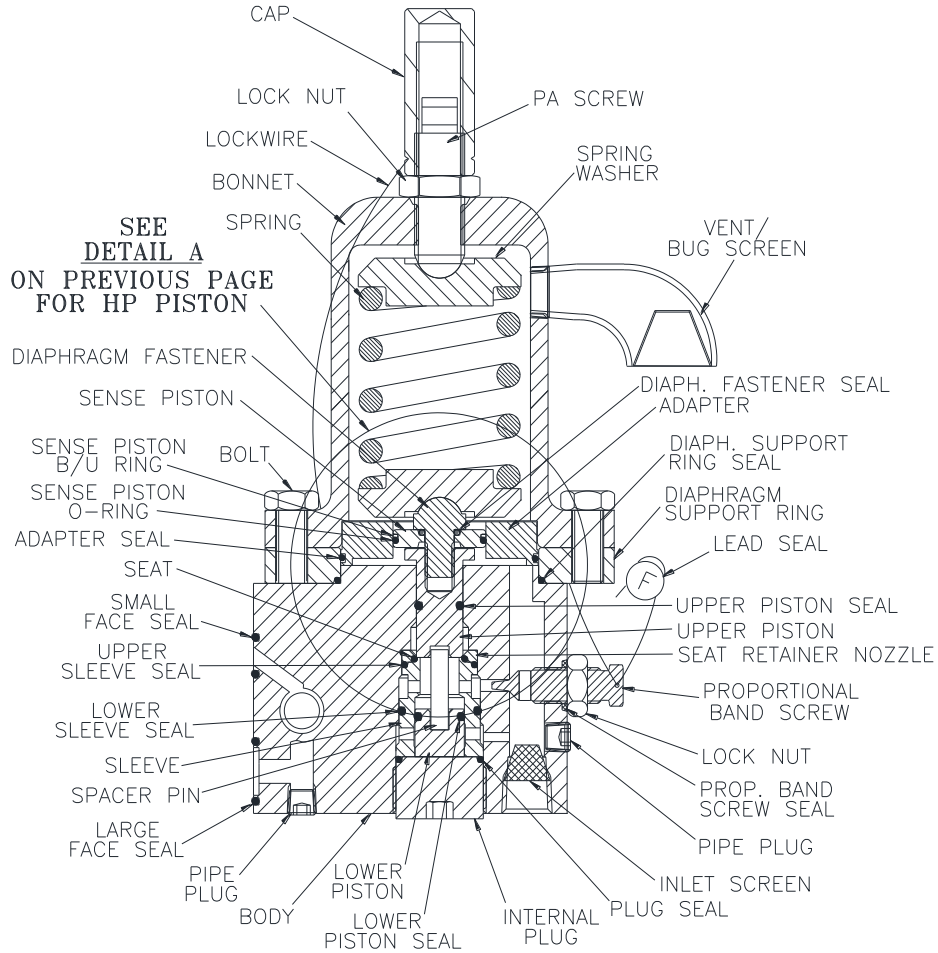

## Integral Module (IM) Construction (legacy):

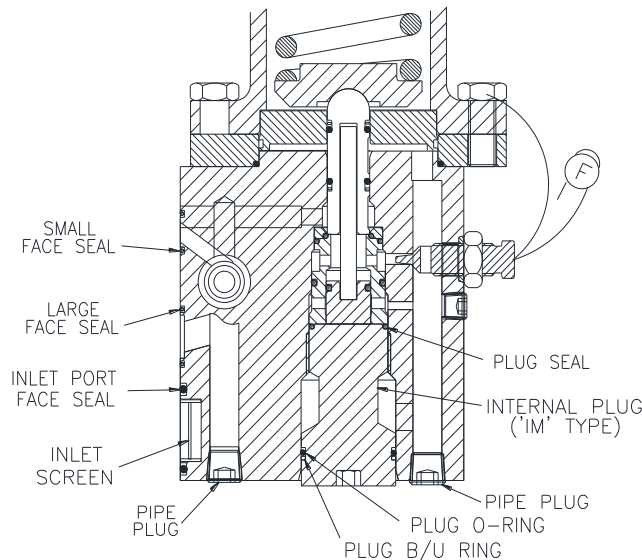

## B. F300 (Piston-style) Assembly

NOTE: Exercise care in handling softgoods, nozzles, and other sealing surfaces.

- 1) Confirm pressure setting and associated parts required.
- 2) Place the valve body in a vise.
- 3) Install pipe plugs into valve body.
- 4) Install backflow preventer (BFP) O-ring onto BFP piston.
- 5) Assemble BFP jam nut and seal onto BFP nozzle. For modified nozzle design with 00-2313-xx O-ring on leading edge, install O-ring with light coat of lubricant to hold it in place in its gland.
- 6) Place BFP piston with O-ring into end of nozzle. Install BFP assembly into valve body until very tight (conventional chamfered nozzle) or snug (O-ring-tipped nozzle), then tighten BFP jam nut so as to crush the Teflon seal.
- 7) Assemble lock nut and proportional band screw seal onto proportional band screw.
- 8) Install the proportional band screw assembly into the valve body. Screw in clockwise until the screw bottoms in the body, and then back out CCW 1-1/2 turns (also see Section 6.3 for band screw adjustment). Tighten lock nut.
- 9) For the IM-construction pilot valve, insert inlet screen into the valve body.
- 10) Lightly lubricate lower sleeve seal with Dow Corning Molykote 33 or equivalent and install into groove of sleeve.
- 11) Lightly lubricate upper sleeve seal and place onto the top of the sleeve. Install the seat into the bottom side of the seat retainer nozzle, and assemble on top of the sleeve.
- 12) Lightly lubricate lower piston seal and install into groove of lower piston. Insert the lower piston assembly into the sleeve until they are flush at the bottom. Then install the seat retainer / sleeve / lower piston subassembly into the valve body until it bottoms. Check to ensure that all seals and O-rings are correctly aligned. The PA screw cap can be used to verify proper fit up. Place the cap on a flat surface, and then lower the pilot body with subassembly onto the cap and push down until the assembly snaps into place and is solid.
- 13) Place the plug seal onto bottom of the sleeve. For IM-construction pilots, install plug O-ring and backup ring onto the internal plug. For all pilots, screw the internal plug into the body until tight. Make sure that the plug is very tight.
- 14) From the top, install spacer pin into the recess in the lower piston previously installed.
- 15) For high-pressure pilots (1481 - 6000 psig): Lightly lubricate upper piston seals and backup rings, and assemble to upper piston in the relative position shown in Detail A, Page 20. Assemble the adapter and adapter seal over the upper piston, making sure that it slides freely over the upper seal.
- 16) For low-pressure piston-style pilots (286-1480 psig): Lightly lubricate upper piston seal and install into groove of upper piston. Assemble diaphragm fastener seal, sense piston, sense piston O-ring, sense piston backup ring, and diaphragm fastener to upper piston. Apply a small amount of Loctite onto the fastener threads. Assemble the adapter and adapter seal over the sense piston.  
Important: The sense piston backup ring must be on top of the O-ring, on the side nearest to the spring. Tighten the diaphragm fastener tightly into the upper piston.
- 17) Install the upper piston assembly into body, making sure that it slides onto spacer pin properly.
- 18) Assemble diaphragm support ring seal and diaphragm support ring onto valve body.
- 19) Assemble spring and spring washers onto diaphragm fastener or HP upper piston, as applicable.
- 20) Install the bonnet over the spring / washers and onto the diaphragm support ring. Align the bonnet and support ring so that the unthreaded through-holes in the support ring line up with the bolt holes in the valve body, and the two small through-holes in the bonnet and support ring align and clear the valve body. The vent / bug screen opening in the bonnet should face away from the main valve mounting surface.
- 21) Install the four long bolts through the bonnet / support ring and into the valve body, and tighten.
- 22) Install the four short bolts through the bonnet and into the diaphragm support ring, and tighten.
- 23) Assemble the PA screw and lock nut into the top of the bonnet.
- 24) Attach the cap to the PA screw, but do not tighten.

- 25) Install vent / bug screen into the bonnet, and the inlet screen into the body.
- 26) Assemble the face seals to the external mounting face of the pilot body. The 'IM' style body has an additional face seal at the inlet port.
- 27) The pilot valve is now completely assembled and ready to be set per Section 5.0.
- 28) If applicable, install lockwire and lead seal between PA screw cap, bonnet, and proportional band screw. Repair tag may be attached to wire.

## **4.5 F500 PILOT VALVE** (See Illustrations on Page 25)

### **A. F500 Disassembly**

**CAUTION:** It is extremely dangerous to attempt to disassemble any valve while it remains in service with incoming line pressure.

- 1) Remove the pilot valve from the main valve, or safely block the incoming pressure before disassembling the valve and performing maintenance.
- 2) Unscrew the pressure adjustment (PA) screw cap from the PA screw. Loosen the lock nut.
- 3) Loosen, but do not remove the PA screw from the bonnet.
- 4) Further disassembly can proceed in the reverse order from the assembly instructions below.
- 5) Replacement soft goods are listed in Section 8.0 of this manual.

### **B. F500 Assembly**

**NOTE:** Exercise care in handling softgoods, nozzles, and other sealing surfaces.

- 1) Confirm pressure setting and associated parts required.
- 2) Place the valve body in a vise.
- 3) Install pipe plug into the valve body.
- 4) Install backflow preventer (BFP) O-ring onto BFP piston.
- 5) Assemble BFP jam nut and seal onto BFP nozzle. For modified nozzle design with 00-2313-xx O-ring on leading edge, install O-ring with light coat of lubricant to hold it in place in its gland.
- 6) Place BFP piston with O-ring into end of nozzle. Install BFP assembly into valve body until very tight (conventional chamfered nozzle) or snug (O-ring-tipped nozzle), then tighten BFP jam nut so as to crush the Teflon seal.
- 7) If the pilot includes the optional Set Point Indicator (SPI), install it as follows:
  - a) Lightly lubricate all O-ring seals.
  - b) Install SPI seat onto SPI pin.
  - c) Tighten SPI pin into SPI piston.
  - d) Install one SPI seal onto SPI piston.
  - e) Insert SPI pin and piston assembly completely into port in pilot body.
  - f) Install SPI pin seal, the other SPI seal, and SPI bushing seal onto SPI bushing.
  - g) Install the SPI bushing into the pilot body with the SPI pin protruding through it. Tighten the bushing securely into the pilot body.
- 8) Lightly lubricate one O-ring seat and install onto seat retainer.
- 9) Install seat and seat retainer into pilot body from bottom.
- 10) Lightly lubricate feedback piston seal and install onto feedback piston.
- 11) Install feedback piston into body from top.
- 12) Install lower seat onto bottom of feedback piston and tighten securely with 7/16" hex driver.
- 13) Lightly lubricate the other O-ring seat and install into retainer.
- 14) Apply small amount of Loctite to threads of spindle. Install retainer securely onto spindle using 3/16" Allen wrench in bottom of spindle and a wrench on the OD flats of the retainer.
- 15) Install the spindle assembly up through the bottom of the pilot body. The spindle should slide freely up and down through the feedback piston.
- 16) Place spindle spring onto top of feedback piston.

- 17) Low Pressure: Place piston into the spindle spring and over the end of the spindle. Install diaphragm fastener seal in top of piston and place the diaphragm on top of the piston. Put the diaphragm washer on top of diaphragm. Place the reducer ring on top of the diaphragm, around the diaphragm washer.  
Intermediate Pressure and High Pressure: Lightly lubricate piston seal and install onto piston. Place the piston into the spindle spring and over the end of the spindle. Lightly lubricate diaphragm fastener seal and install it onto diaphragm fastener.
- 18) Apply a small amount of Loctite (or equivalent) onto the threads of the diaphragm fastener. Tighten the diaphragm fastener into the top of the spindle using a 3/16" Allen wrench in the bottom of the spindle and a 9/16" wrench on the diaphragm fastener.
- 19) All except IM High Pressure: Install inlet screen into bushing. Lightly lubricate bushing seal and spindle seal and install them into bushing.  
IM High Pressure: Install inlet screen into inlet port of body. Lightly lubricate bushing seal, spindle seal, lower bushing seal, and lower bushing seal backup ring and install them into bushing.
- 20) Install the bushing into the bottom of the pilot body and tighten securely.
- 21) Low Pressure: Lightly lubricate diaphragm support ring seal and install it onto top of pilot body.  
Intermediate Pressure and High Pressure: Lightly lubricate piston ring seal and install it into piston ring.
- 22) Low Pressure: Place the diaphragm support ring underneath the diaphragm and onto the top of the pilot body. Align the four unthreaded clearance holes in the ring with the four threaded holes in the pilot body. The small lockwire hole in the ring should overhang the edge of the body where it will align with a lockwire hole in the bonnet.  
Intermediate Pressure: Place the piston ring around piston and onto the top of the pilot body. Align the four unthreaded clearance holes in the ring with the four threaded holes in the pilot body. The small lockwire hole in the ring should overhang the edge of the body where it will align with a lockwire hole in the bonnet.  
High Pressure: Place the piston ring around piston and onto the top of the pilot body. Install four socket head cap screws through ring into body and tighten securely.
- 23) Apply lubricant to center of each spring washer. Insert the small end of the spring washers into each end of the spring and place onto top end of diaphragm fastener.
- 24) Low Pressure and Intermediate Pressure: Place bonnet over spring and down onto top of diaphragm support ring or piston ring. Align bolt holes in bonnet with the bolt holes in the ring. The bonnet vent hole should be facing away from the front (mounting face) of the pilot. The lockwire holes in the bonnet and ring should be aligned.  
High Pressure: Place bonnet over spring and down onto top of piston ring. Screw bonnet onto ring until tight, then adjust position of bonnet until vent hole is facing away from the front (mounting face) of the pilot.
- 25) Low Pressure and Intermediate Pressure: Install the short bonnet bolts into the holes aligned with the threaded holes in the diaphragm support ring or piston ring. Install the long bolts into the holes aligned with the clearance holes in the ring and into the threaded holes in the body. Snug the bonnet bolts in an alternating pattern and then gradually tighten them securely in an alternating pattern.  
High Pressure: Apply Loctite to the two set screws, install them into the bonnet, and tighten them securely.
- 26) Install the vent / bug screen into the bonnet, ensuring that the male NPT end does not contact the spring. Apply Teflon tape to threads before installing.
- 27) Assemble the PA screw and lock nut into the top of the bonnet.
- 28) Attach the cap to the PA screw, but do not tighten.
- 29) Install the face seals onto the external mounting face of the body.
- 30) The pilot valve is now completely assembled and ready to be set per Section 5.0.
- 31) If applicable, install lockwire and lead seal between PA screw cap, bonnet and inlet bushing. Repair tag may be attached to wire.

# INSTALLATION, OPERATION, & MAINTENANCE MANUAL



TITLE: F7000 / 8000 Series  
Pilot-Operated Safety Relief Valve

Rev. W  
Page 25 of 41

**BACKFLOW PREVENTER (BFP) OPTIONS**  
SECTION A-A

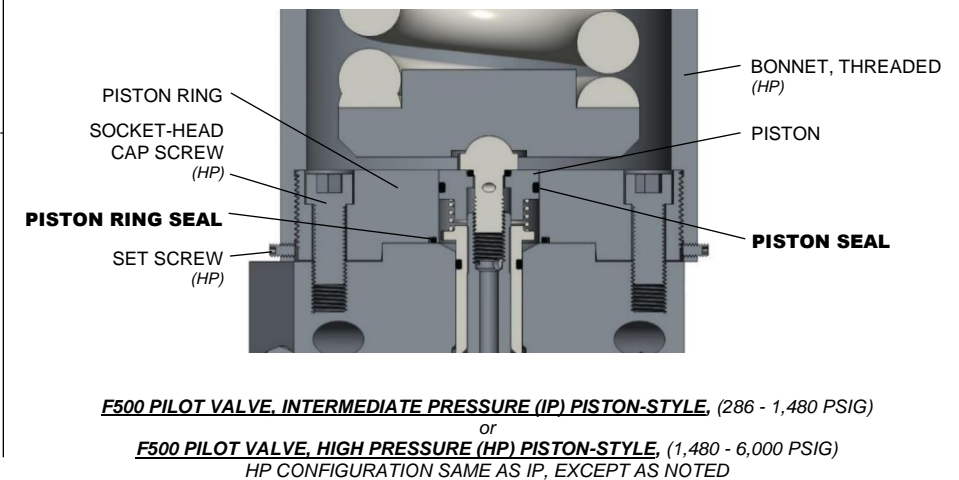
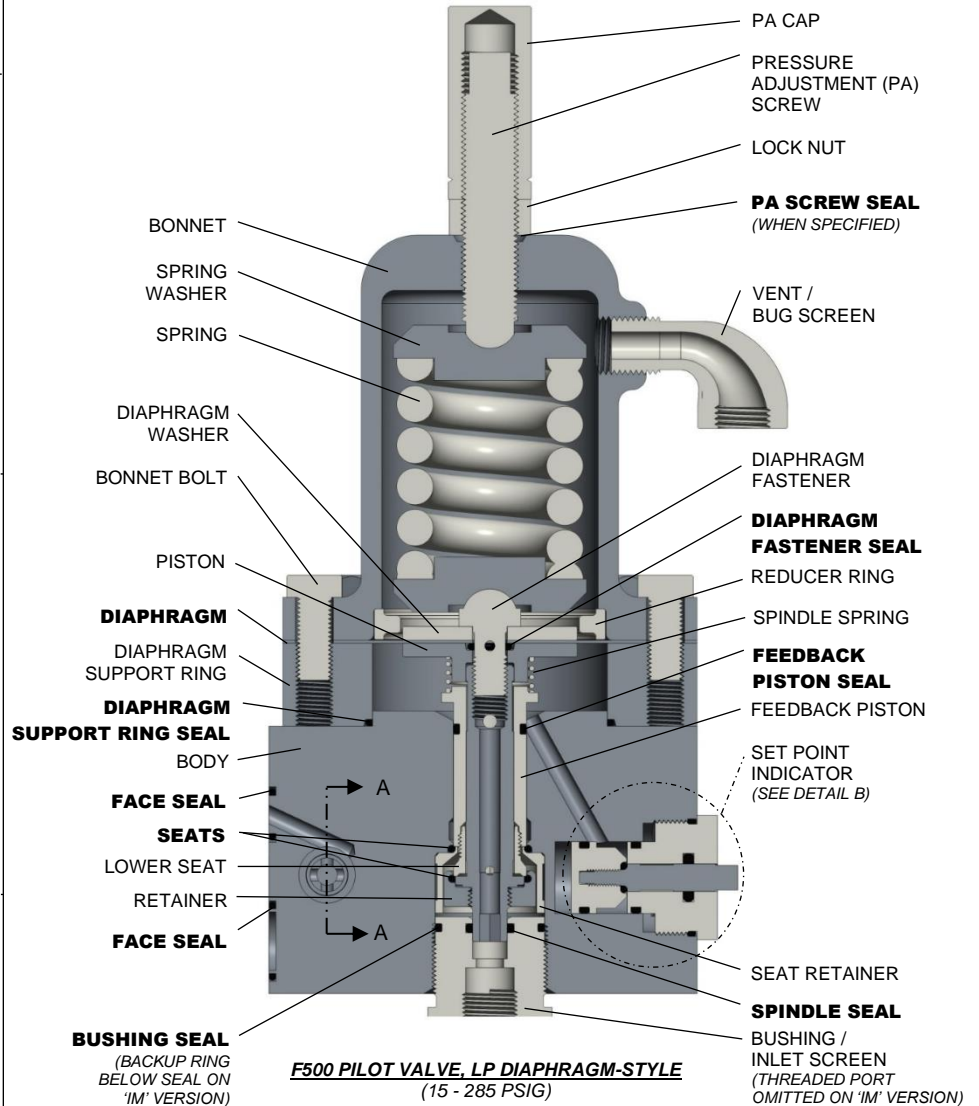
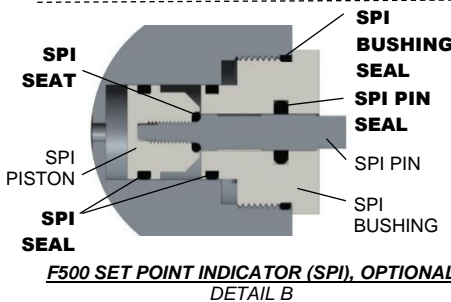
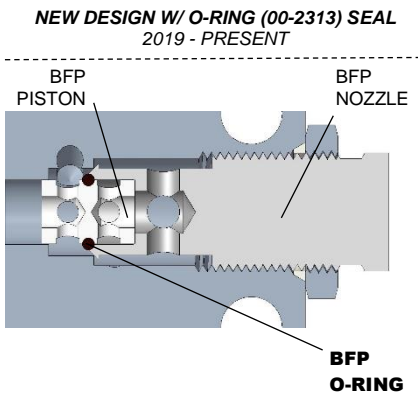
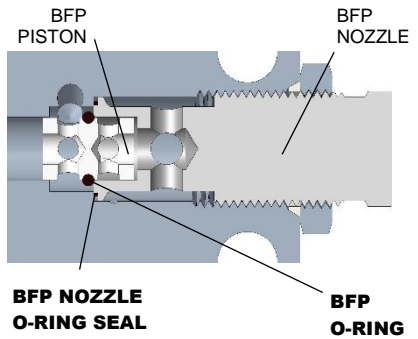
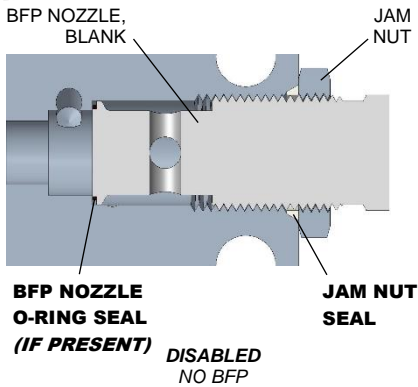

## F500 PILOT VALVE ASSEMBLY



**5.0 PILOT VALVE SET PRESSURE ADJUSTMENT**

**5.1** *Set pressure* may be defined in terms of ASME Section VIII or US DOT regulations for natural gas transmission and distribution, subject to the jurisdiction in effect at the particular valve installation. Contact Flow Safe for confirmation of spring range or new spring part number before resetting any pilot to a different set pressure.

5.1.1 ASME VIII: Set pressure is the inlet supply pressure at which the main piston opens or main valve dome pressure is reduced so as to permit the piston to open (based differential between piston seat and top seal). The ASME Sec. VIII tolerance on set pressure is  $\pm 2$  psi for set pressures  $\leq 70$  psig, and  $\pm 3\%$  of set pressure for set pressures  $> 70$  psig.

5.1.2 DOT: Set pressure is the point of first exhaust from the pilot. Tolerances are the same as in 5.1.1 above. Main piston lift should follow within 3 to 5% of set pressure value after pilot first exhaust. This setting method normally applies to the Flow Safe F70PR valve series, but may apply to the F7000/8000 series if ordered for a DOT application.

**5.2 PRESSURE ADJUSTMENT / VERIFICATION**

**5.2.1 Testing of Pilot Only**

Set pressure adjustments can be made with the pilot valve removed from the main valve and connected to a test plate assembly (available from Flow Safe), as shown below. The adjustment is made by turning the pressure adjusting screw clockwise (in) to increase set pressure and counterclockwise (out) to decrease set pressure.

The F200 snap-acting pilot will suddenly exhaust dome to zero in a “pop” action.

F100, F300, and F500 modulating pilots gradually reduce dome pressure to the point where the piston can lift, as follows:

<u>F7000/8000 Valve Size</u>	<u>Dome Pressure % at Set Point *</u>	<u>F7000/8000 Valve Size</u>	<u>Dome Pressure % at Set Point *</u>
1 x 2	50 %	6 x 8	80 %
1-1/2 x 3	63	8 x 10	84
2 x 3	68	10 x 12	78
3 x 4	76	12 x 16	73
4 x 6	76		

\* Dome pressure as a percentage of inlet pressure, to achieve main valve piston lift (F100, F300, F500)

**Example:** For a 3x4 set at 150 psig to begin discharging through the outlet, a modulating pilot must vent off dome pressure until it drops to approx. 114 psig (0.76 x 150).

Detailed pilot testing instructions are contained in Sections 5.3 through 5.6. Auxiliary setter adjustments are detailed in 5.7.



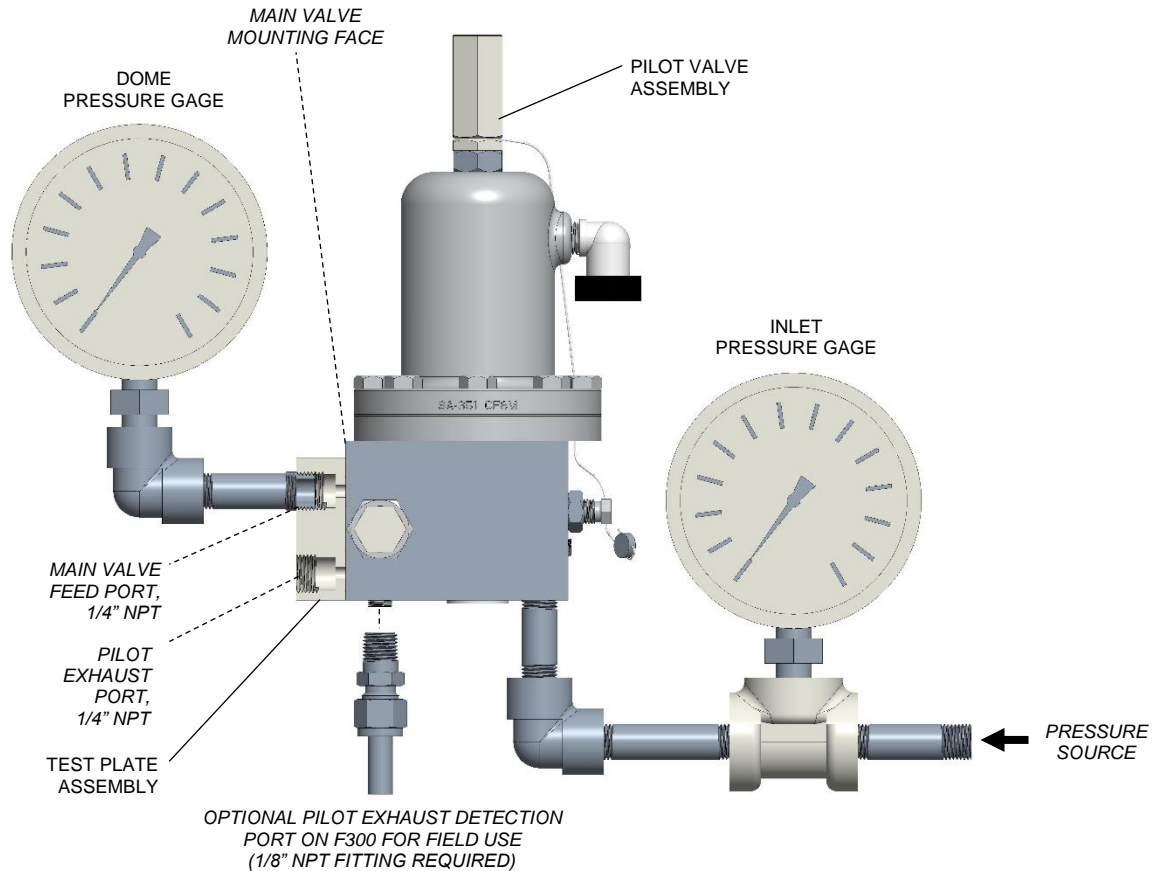

**PILOT VALVE TEST ARRANGEMENT**  
F300 PILOT SHOWN

## 5.2.2 Testing of Complete Assembly

**CAUTION:** Extreme care must be taken when testing or servicing a pressure relief valve used in gas or incompressible fluid service. The service medium may be volatile and under high pressure.

**CAUTION:** Performance of the procedure below will cause the main valve to open, unless inlet pressure is closed off by a block valve or the system is depressurized.

If a portion of the relief valve's system or a test tank large enough to mount the main valve inlet is available for test, set pressure can be checked on the complete relief valve assembly. The main valve outlet will need to be open and accessible in order to verify flow from the main piston, or alternate methods will need to be used to detect pilot set point per Section 6.4, step (B)(4). Refer to the detailed pilot testing instructions in Section 5.3, 5.4, 5.5, or 5.6 for making adjustments.

- 1) First, leak testing of main valve components should be performed per Section 6.0.
- 2) Slowly increase system or test tank pressure to set point. See 5.1 for set pressure definition.
- 3) Verify that the main piston starts to open or pilot starts to exhaust at set point, as applicable.
  - a) The F100, F300, and F500 will start exhausting dome pressure at approximately 95% to 98% of set pressure for ASME VIII applications, and at set pressure for DOT applications. Pilot flow will be audible on gas flow, and result in a small trickle in liquid service. Flow will increase significantly once the main piston opens.
  - b) The F200 pilot pops open at set pressure along with the main piston. Remain clear of main valve outlet during testing, as piston will pop open.

## **5.3 F100 PILOT VALVE ADJUSTMENT** (See Illustrations on Pages 15 and 27)

- 1) The set pressure for the F100 high-pressure pilot valve may be adjusted by turning the pressure adjusting (PA) screw, or changing springs or corresponding spacer combinations. Springs and spacers are matched in three different set pressure ranges: 4 to 136 psig, 100 to 405 psig, and 293 to 720 psig. Contact Flow Safe to verify the proper spring and spacer combination.
- 2) Attach pilot valve assembly to the test tank with the cap removed and the PA screw turned in to approximately where the set point is believed to be.
- 3) Slowly increase inlet pressure to set point, as defined in 5.1.
- 4) Dome pressure and inlet pressure should increase together until first bubble (or first flow of liquid) from the pilot exhaust occurs (at approx. 95 - 97% of set pressure for ASME settings), and then dome pressure should begin decreasing.
- 5) If dome pressure does not drop to the specified value within 3 – 5% after pilot first exhaust, adjust the PA screw as necessary. If further adjustments fail to achieve the required dome reduction, stop the test, disassemble the pilot valve, and inspect parts as required.
- 6) After dome pressure drops to the specified value (or lower), slowly lower the test tank pressure until the pilot closes and the exhaust flow stops. At this point dome pressure and inlet pressure will equalize. Pilot leakage should stop at an inlet pressure of no less than 90% of set pressure for ASME settings, or 95% for DOT settings.
- 7) Increase the test tank pressure slowly until the dome pressure drops again. Continue flowing test fluid to the pilot valve and check for modulation.
- 8) When the set pressure has been adjusted to the desired settings, tighten the PA screw lock nut.
- 9) Install and tighten the cap onto the PA screw.
- 10) Repeat the test to verify repeatable performance.
- 11) With the pilot valve assembly pressurized to just under set point, inspect all tubing, connections, and fasteners for leaks.

## **5.4 F200 PILOT VALVE ADJUSTMENT** (See Illustrations on Pages 17 and 27)

- 1) The set pressure for the F200 Pilot Valve may be adjusted only by turning the pressure adjusting (PA) screw or changing springs. Contact Flow Safe to verify the proper spring for the desired set pressure.
- 2) Attach pilot valve assembly to the test tank with the cap removed and the pressure adjustment screw turned in to above where the set point is believed to be.
- 3) Apply pressure to the test tank up to slightly less than the designated set pressure.
- 4) Slowly increase the test tank pressure toward the set point. The dome pressure gauge should increase at the same rate and reading as the test tank gauge.
- 5) At the designated set pressure value, slowly turn the PA screw counterclockwise until the pilot valve assembly exhausts. Check that the dome reservoir gauge drops to 0 (zero) psig.
- 6) If the dome pressure drops to zero, slowly lower the test tank pressure until the pilot closes and the dome gauge recovers back to the inlet pressure value. If the dome pressure does not drop to zero, stop the test and disassemble and inspect the parts.
- 7) At the point of dome gauge recovery, record the test tank pressure gauge reading. The difference between this pressure and set point will be the pilot valve blowdown.
- 8) The valve blowdown should be approximately 7% of set pressure, or as specified. To shorten blowdown turn the bushing into the valve body (clockwise). To lengthen blowdown turn the bushing out of the valve body (counterclockwise). Blowdown can also be adjusted by holding the bushing stationary and turning the valve body. The bushing jam nut must be tightened after each blowdown adjustment.
- 9) When the set pressure and blowdown have been adjusted to the desired settings, tighten the PA screw lock nut and bushing jam nut.
- 10) Install and tighten the cap onto the PA screw.
- 11) Repeat the test to verify repeatable performance.

- 12) Backflow preventer test:
  - a) Attach a pressure supply line to the exhaust port of the test fixture block.
  - b) Reduce the pressure in the test tank to approximately 50% of the pilot valve set pressure or 50 psig, whichever is lower.
  - c) Slowly increase the pressure through the exhaust port. As this pressure increases above the test tank pressure, the dome pressure gage should begin to increase and read the same as the exhaust port pressure. If this occurs, the backflow preventer is working properly. If this does not occur, disassemble and inspect the parts.

## **5.5 F300 PILOT VALVE ADJUSTMENT** (See Illustrations on Pages 18, 20, 21 and 27)

- 1) The set pressure for the F300 pilot valve may be adjusted by turning the pressure adjusting (PA) screw, changing springs, or by exchanging diaphragm-style and piston-style internals. Contact Flow Safe to verify the proper parts for the desired set pressure.
- 2) Attach pilot valve assembly to the test tank with the cap removed and the pressure adjustment screw turned out to below where the set point is believed to be.
- 3) Slowly increase inlet pressure to set point, as defined in 5.1.
- 4) Dome pressure and inlet pressure should increase together until first bubble (or first flow of liquid) from the pilot exhaust occurs (at approx. 96 - 98% of set pressure for ASME settings), and then dome pressure should begin decreasing.
- 5) Adjust the PA screw as necessary to cause dome pressure to drop to the specified value within 2 – 4% after pilot first exhaust . If further adjustments fail to achieve the required dome reduction, stop the test, disassemble the pilot valve, and inspect parts as required.
- 6) After dome pressure drops to the specified value (or lower), slowly lower the test tank pressure until the pilot closes and the exhaust flow stops. At this point dome pressure and inlet pressure will equalize. Pilot leakage should stop at an inlet pressure of no less than 94% of set pressure for ASME settings, or 96% for DOT settings.
- 7) Increase the test tank pressure slowly until the dome pressure drops again. Continue flowing test fluid to the pilot valve and check for modulation.
- 8) If necessary for smoother modulation, make minor adjustments to the proportional band screw as originally set in Section 4.3 or 4.4. The screw should not be backed out more than a total of about 2-1/2 turns. See Section 6.3 for more detail on this adjustment.
- 9) When the set pressure and modulating action have been adjusted to the desired settings, tighten the PA screw lock nut and proportional band screw lock nut.
- 10) Install and tighten the cap onto the PA screw.
- 11) Repeat the test to verify repeatable performance.
- 12) With the pilot valve assembly pressurized to just under set point, inspect all tubing, connections, and fasteners for leaks.
- 13) Backflow preventer test:
  - a) Attach a pressure supply line to the exhaust port of the test fixture block.
  - b) Reduce the pressure in the test tank to approximately 50% of the pilot valve set pressure or 50 psig, whichever is lower.
  - c) Slowly increase the pressure through the exhaust port. As this pressure increases above the test tank pressure, the dome pressure gage should begin to increase and read the same as the exhaust port pressure. If this occurs, the backflow preventer is working properly. If this does not occur, disassemble and inspect the parts.

## 5.6 F500 PILOT VALVE ADJUSTMENT (See Illustrations on Pages 25 and 27)

- 1) The set pressure for the F500 pilot valve may be adjusted by turning the pressure adjusting (PA) screw, or by changing springs, corresponding diaphragm, or sense piston arrangements. For the low pressure diaphragm-style pilot, springs and diaphragm parts are matched in a set pressure range of 15 to 285 psig. For the intermediate pressure piston-style pilot, springs and piston parts are matched in a set pressure range of 286 to 1480 psig. For the high pressure piston-style pilot, springs and piston parts are matched in a set pressure range of 1481 to 6000 psig. Contact Flow Safe to verify the proper parts for the desired set pressure.
- 2) Attach pilot valve assembly to the test tank with the cap removed and the PA screw turned out to below where the set point is believed to be.
- 3) Slowly increase inlet pressure to set point, as defined in 5.1.
- 4) Dome pressure and inlet pressure should increase together until dome pressure stops rising at approximately 93 - 94% of set pressure (this point is referred to as "lock-out"). As inlet pressure increases further, first bubble (or first flow of liquid) from the pilot exhaust should occur and dome pressure should begin decreasing at approximately 96 - 98% of set pressure for ASME settings. (NOTE: If optional Set Point Indicator is included, the set point indicator pin should move in when dome pressure has decreased to approximately 86% of inlet pressure.)
- 5) If dome pressure does not drop to the specified value within 2 – 4% after pilot first exhaust, adjust the pressure adjusting screw as necessary. Decrease pressure to 90% or less of set pressure, allowing inlet and dome pressure to equalize, before checking set pressure again. (NOTE: If optional Set Point Indicator (SPI) is included, the SPI pin should return to the out position when inlet and dome pressure equalize.) Tighten down the PA screw lock nut when adjustment is complete.
- 6) If the pilot leaks from exhaust at pressures less than first bubble point, as described above, or if set point cannot be properly set, discontinue the test and disassemble the valve and check parts.
- 7) Install and tighten the cap onto the PA screw.
- 8) Repeat the test to verify repeatable performance.
- 9) With the pilot valve assembly pressurized to just under set point, inspect all tubing, connections, and fasteners for leaks.
- 10) Backflow preventer test:
  - a) Attach a pressure supply line to the exhaust port of the test fixture block.
  - b) Reduce the pressure in the test tank to approximately 50% of the pilot valve set pressure or 50 psig, whichever is lower.
  - c) Slowly increase the pressure through the exhaust port. As this pressure increases above the test tank pressure, the dome pressure gage should begin to increase and read the same as the exhaust port pressure. If this occurs, the backflow preventer is working properly. If this does not occur, disassemble and inspect the parts.

## 5.7 PILOT AUXILIARY SETTER ADJUSTMENT (See Illustration below)

- 1) The set pressure for the pilot auxiliary setter may be adjusted by turning the pressure adjusting (PA) screw or changing springs. Contact Flow Safe to verify the proper spring for the desired set pressure.
- 2) The auxiliary setter must be installed on its designated pilot valve when being adjusted. This may be verified by means of matching serial numbers. The set pressure will be the pilot set pressure plus the auxiliary setter differential pressure.
- 3) Attach pilot valve assembly, with auxiliary setter, to the test tank.
- 4) The auxiliary setter cap and adapter cap should be removed and the pressure adjustment screw turned out to below where the set point is thought to be.
- 5) Slowly increase inlet pressure to set point, which occurs when dome pressure decreases to the percentage of inlet pressure listed in 5.2.1 (Page 26) for the particular valve size.
- 6) Adjust the PA screw as necessary to cause dome pressure to drop to the specified value at the required set pressure. If further adjustments fail to achieve the required dome reduction, stop the test, disassemble the auxiliary setter, and inspect parts as required.
- 7) When the total set pressure (i.e. original pilot set pressure plus the auxiliary setter differential pressure) has been adjusted to the desired setting, tighten the PA screw lock nut.
- 8) Install and tighten the adapter cap onto the bonnet and then install and tighten the cap onto the adapter cap.
- 9) Repeat the test to verify repeatable performance.

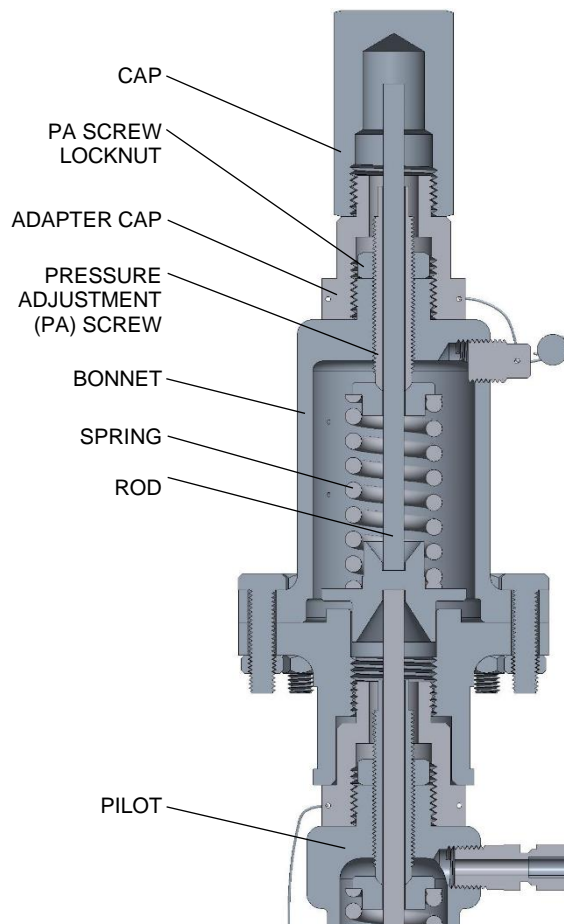

**PILOT AUXILIARY SETTER ARRANGEMENT**  
F100 PILOT SHOWN w/ SINGLE AUX SETTER



## 6.0 SUPPLEMENTAL TESTING AND ACCESSORIES

### 6.1 TESTING OF THE MAIN VALVE SUBASSEMBLY

When main valve reassembly is complete, the assembly should be tested for leakage and piston lift on a test stand according to the following:

- 1) To enable separate control of pressure sources to the main valve dome and inlet, a hydro test plate (available from FLOW SAFE) should be installed on the pilot mounting pad, as shown in the figure below.
- 2) To test the piston seal, liner seals, and (for 'IM' construction) top spool piece seals, pressurize the dome with 10% to 90% of set pressure. With a bubble tester, wet paper towel, or plastic wrap covering the outlet, verify that there is no leakage. Also verify no leakage around the cap and cap bolts by spraying the area thoroughly with soapy water.
- 3) To test the main valve seat, re-pressurize the dome as in (2), and introduce pressure at the inlet up to 40% of dome pressure. Check for leakage at the main valve outlet.
- 4) Apply pressure to the field test connection to test the integrity of the FTC seals and (for 'IM' construction) the lower spool seal.
- 5) With no pressure to the dome, pressurize the inlet up to 5 psig. The piston should open slightly, allowing air to discharge through the outlet of the valve.
- 6) To check for full piston lift, install a blind flange on the valve outlet. Again pressurize the inlet up to 5 psig. The piston should fully lift and hit the bottom of the cap, as indicated by a clear sound of metal-to-metal contact. When the outlet flange is removed, the piston will frequently fall to the closed position.
- 7) If the valve fails, disassemble the valve and examine the soft goods for contamination or damage, or consult the troubleshooting guide in Section 7.0 of this manual.

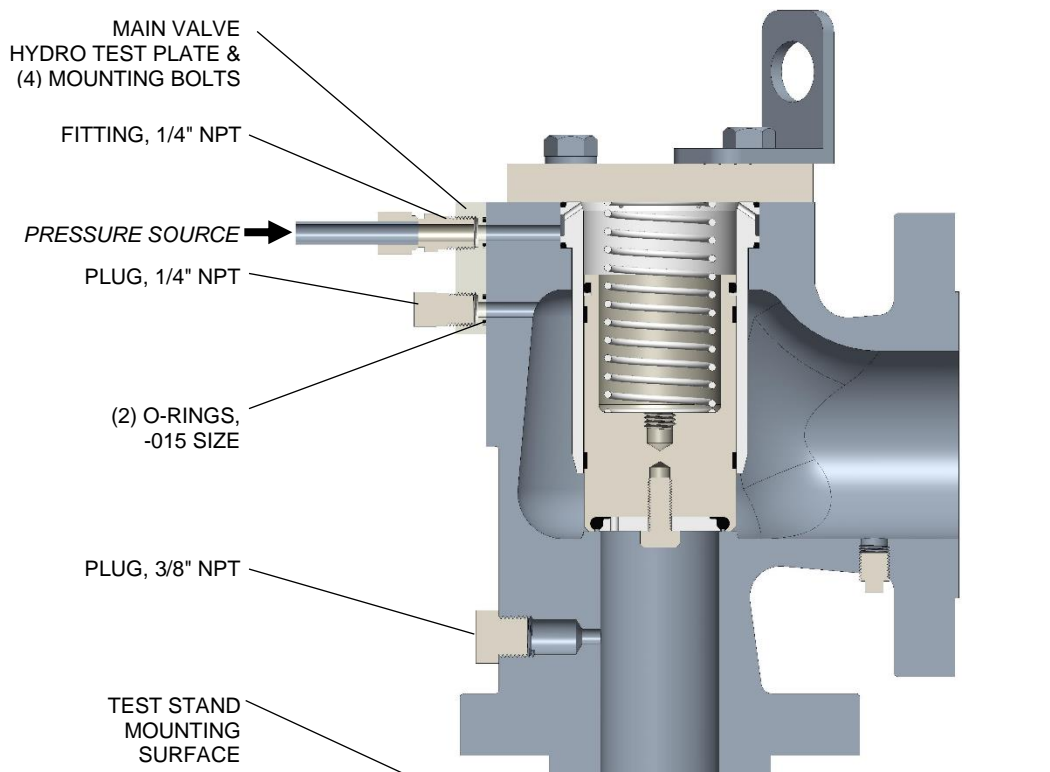

**MAIN VALVE TEST ASSEMBLY SETUP**  
F7000 SHOWN

## **6.2 FINAL ASSEMBLY TESTING**

- 1) Thoroughly clean off the mounting surfaces on both the main valve and pilot valve face. Make sure that the face seals are clean and in good condition.
- 2) Apply a light coat of lubricant (e.g., Dow Corning 33) to the face seals.
- 3) Assemble the pilot valve to the main valve with 5/16"-24UNF mounting bolts (4 for standard construction; 6 for 'IM' construction). A light coating of Loctite or Vibra-tite should be applied to the bolts. Tighten the bolts securely.
- 4) Install and tighten all pilot tubing connections, except for 'IM' construction valves.
- 5) Mount the assembly to the test stand and pressurize up to 90% of set pressure.
- 6) Check for leaks at all joints, including tubing connections, pilot valve mounting surface, field test connection, cap, cap bolts, and at valve outlet. There should be no leaks anywhere.
- 7) Once testing is complete, the valve assembly is ready for installation. If applicable, flange protectors should be installed and other protection measures taken during transport.

## **6.3 F300 PILOT VALVE PROPORTIONAL BAND ADJUSTMENT**

### **A. Purpose**

The FLOW SAFE F300 Series is a modulating-style pilot valve used with the F7000/8000 Series. As received from the factory, the F300 is lockwired to prevent any adjustments to the set pressure. This lockwire is also attached to the proportional band screw (see drawings on Page 18, 20, 21 and 27).

For the main valve to remain closed, system pressure must fill the valve dome at the same rate as the buildup below the piston. In an application where the relief valve may be prematurely lifting due to excessive inlet pressure increase, the proportional band screw may be adjusted to increase the dome fill rate through the pilot assembly.

The proportional band screw setting also affects the spread between pilot first-bubble (exhaust) and dome reduction required to open the main valve (see 5.2.1), by affecting the rate at which dome reduction occurs. As the screw is adjusted in the CW direction, the spread between first exhaust and dome reduction will decrease and dome reduction will occur at a faster rate. As the screw is turned CCW out to the maximum setting noted in (5) below, the spread between first exhaust and dome reduction increases slightly and the rate of dome reduction slows down.

This adjustment will not affect the set pressure of the valve.

### **B. Procedure**

- 1) Relieve the pressure below the relief valve as much as possible.
- 2) Close the block valve, if available, below the relief valve.
- 3) Pressurize the relief valve inlet. The relief valve should remain closed as pressure increases.
- 4) If the valve still opens prematurely, cut the lock wire at the proportional band screw and loosen the lock nut.
- 5) Back out the proportional band screw an additional 1/8 to 1/4 turn, but do not exceed a total of 2-1/2 CCW turns. Retest the valve per step (3). NOTE: The band screw should be 1-1/2 turns out (in the CCW direction) as a result of assembly performed per Section 4.3 or 4.4.
- 6) If the relief valve operates satisfactorily, tighten the lock nut and reinstall the lockwire.
- 7) If the valve continues to open prematurely, repeat step (5) as necessary. If the proportional band screw is at its adjustment limit, attach a remote pressure pickup directly to the pilot as described in Section 2.5.

## 6.4 INSERVICE TESTING WITH THE FIELD TEST CONNECTION (FTC)

**CAUTION:** Extreme care must be taken when testing or servicing a pressure relief valve used in gas or incompressible fluid service. The service medium may be volatile and under high pressure.

**CAUTION:** If a solid 1/4" NPT plug is present in the field test body when performing Step (1) below, do not remove it unless the relief valve inlet is depressurized. The shuttle piston inside the FTC body likely has been removed, which will prevent routine field testing with an external pressure source.

**CAUTION:** Performance of Step (4) below will cause the main valve to open, unless inlet pressure is closed off by a block valve or the system is depressurized.

### A. General

The FTC allows the user to verify set pressure and reseal pressure with the pressure relief valve in service. An external pressure source is attached to the FTC to direct pressure to the pilot valve, while blocking off system pressure to the pilot valve. Review 5.1 for definition of set pressure.

### B. Test Procedure

- 1) Unscrew the 1/4" vented plug from the outboard side of the FTC. The 1/16" diameter vent hole prevents pressure buildup behind the FTC piston and allows it to seat with system pressure.
- 2) Attach the test equipment to the FTC, as shown on Page 35. NOTE that the test pressure gage location close to the main valve will yield pressure readings more representative of what the pilot valve is sensing (especially the F100 or F300), without effects of pressure loss through the hose.
- 3) If there is a remote sense line with manual valve present, as shown on Page 9, close the manual valve. If present, open lower manual valve in-line in pilot tubing to allow field test pressure to pilot. With an external pressure source at a higher pressure than system pressure (but less than set pressure), slowly open the block valve to the source. This will close off the FTC shuttle piston against system pressure and open the passage between the hose and pilot valve.
- 4) a) Without dome gage installed: Set pressure will occur when pilot exhaust flow is detected on the F200 pilot or slightly after (2-5% of nominal set pressure) initial exhaust flow is detected on the F100, F300, or F500 pilot for ASME settings (at set pressure for DOT settings). Pilot flow may be audible at the main valve outlet, or some valves may be fitted with a special test block for detecting pilot flow. The F300 has an access port for detecting first exhaust with a tube and container of water (See diagram on p. 29). NOTE that sufficient dome reduction by pilot will open main valve with system pressure present at inlet.

If pilot exhaust flow cannot be detected at a field installation, set pressure of the F100 and F300 will be approximated by a stop in inlet pressure rise if this pressure is increased very slowly. These modulating pilots begin exhausting dome pressure before the main valve piston opens. The F500 pilot locks out dome from inlet as inlet pressure rises to 93-94% of set pressure, even throughout the brief exhaust period corresponding to set pressure.

b) With dome gage installed: Continue to increase the external pressure until the dome gage drops. The set pressure will be the pressure indicated on the test gage when the dome gage drops to zero for the F200 pilot, or to the value listed in 5.2.1 (Page 26) for the F100, F300, or F500 modulating pilot set per ASME VIII. NOTE that sufficient dome reduction by the pilot will open the main valve with system pressure present at the inlet.

- 5) Slowly open the bleed valve and decrease pressure to the pilot until the dome gage repressurizes. If not using a dome gage, pilot exhaust flow stops completely upon reseal.

# INSTALLATION, OPERATION, & MAINTENANCE MANUAL



**TITLE: F7000 / 8000 Series Pilot-Operated Safety Relief Valve**

**Rev. W  
Page 35 of 41**

- NOTE: 1. For an F200 snap-acting pilot, pilot valve “reseat” pressure will be that pressure at which the dome gage repressurizes.  
 2. For an F100 or F300 modulating pilot, the dome gage will start to increase back to test gage pressure as soon as test pressure drops below set pressure.  
 3. For an F500 no-flow modulating pilot, pilot valve “reseat” pressure will be that pressure at which the dome gage begins to repressurize.
- 6) To safely remove the test equipment, close the block valve to the external pressure source and keep the bleed valve open. This will cause system pressure to be routed to the pilot valve.
- 7) Screw the 1/4” NPT vented plug back into the FTC.

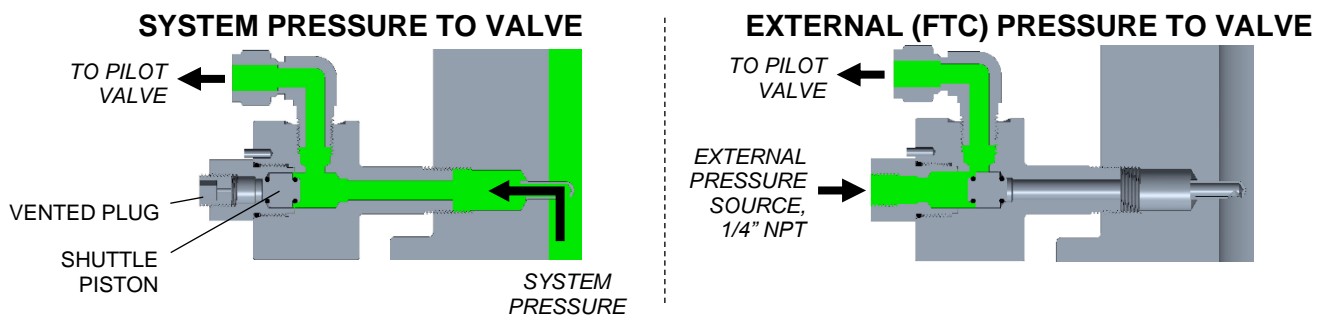
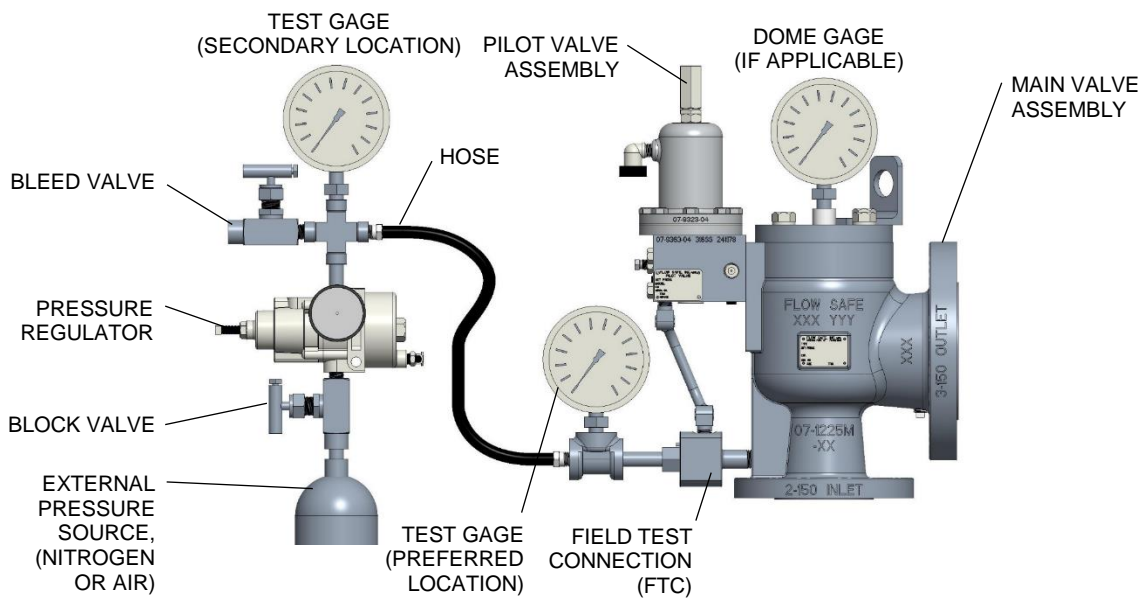

## FIELD TEST CONNECTION (FTC) OPERATION

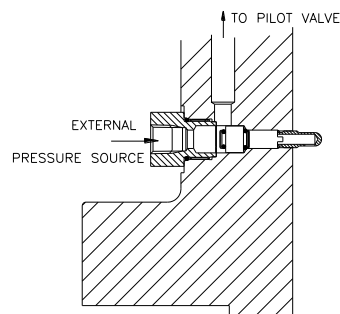

## Integral Module (IM) Construction (legacy)

## 6.5 HARGUARD CLEAN PILOT SUPPLY TANK

The Harguard clean pilot supply tank isolates critical relief valve parts from a corrosive or dirty system process, and permits only a clean liquid such as glycol and water to enter the pilot and main valve dome. A relief cycle will cause the initial charge of clean liquid to be exhausted through the main valve outlet. The subsequent repressurization through the tank will replenish clean liquid to the pilot and main valve dome for a fixed number of relief cycles, depending on the valve size. The tank will then need to be flushed and refilled for continued service.

- 1) For normal system operation, close the drain valve and vent / field test conn. valve, and open the filter inlet valve and system block valve. Refer to illustration below.
- 2) When the liquid level is a minimum of 1/4 full, the tank will need to be flushed and refilled. With the main valve inlet depressurized, close the system block valve and filter inlet valve, and open the vent / field test valve. Remove the pipe plug from the spare connection on top of the tank. Open the drain valve and flush the tank with a suitable liquid to remove sediment and other impurities.
- 3) To fill the tank, close the drain valve and open the filter inlet valve. The new liquid supply can be fed in through the vent / field test valve or the open pipe plug connection. At this time, the filter drain plug can be removed to provide a flush of the filter element.
- 3) Before pressurizing the relief valve, reinstall the filter drain plug and pipe plug at the top of the tank, and close the vent / field test valve. Open the system block valve when ready to admit pressure to the pilot and main valve dome. For remote-sensed systems, pressure should be restored to the main valve inlet only after the pilot and dome are pressurized.

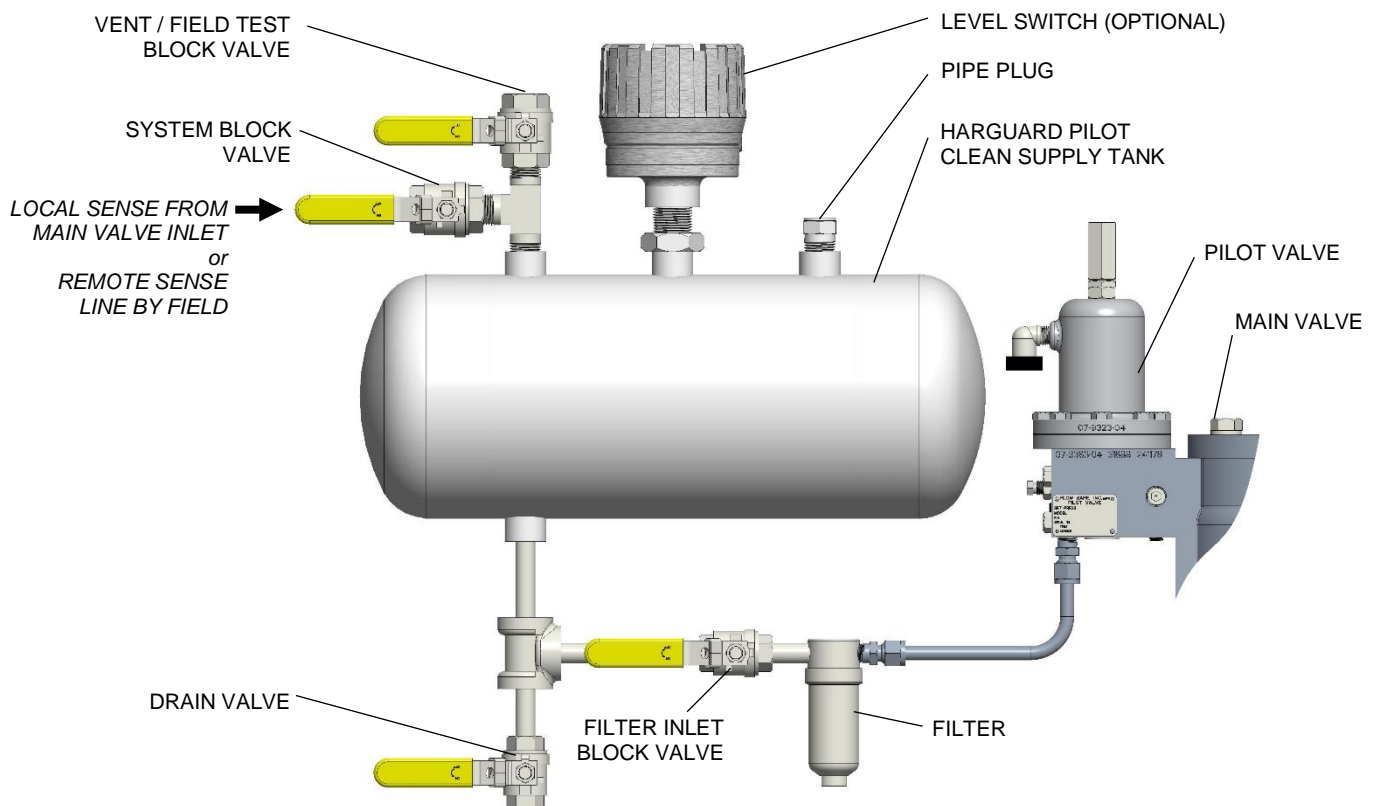



# INSTALLATION, OPERATION, & MAINTENANCE MANUAL



**TITLE: F7000 / 8000 Series  
Pilot-Operated Safety Relief Valve**

**Rev. W  
Page 37 of 41**

## 7.0 TROUBLESHOOTING GUIDE:

Symptom	Possible Cause	Remedy
The main valve leaks around the cap.	Inadequate or uneven bolt torque.	Retighten the cap bolts per Section 3.2.
	Sealing surface on cap is damaged.	Repair defect or replace cap.
	Upper liner seal is damaged, contaminated, or not properly seated.	If damaged, replace with new seal(s). If contaminated, clean and reinstall with light, even pressure in groove.
The main valve leaks through the outlet.	Damage to, or contamination on: piston seat or main valve nozzle, piston seal / sealing surface, or lower liner seal / sealing surface.	Disassemble the valve, remove the piston and liner, and examine the seat, seals, and sealing surfaces under magnification. If damaged, replace with new part(s); if contaminated, clean and reinstall.
	Dome is not loading properly through pilot.	See "The main valve does not close."
The main valve does not close.	Obstruction in pilot valve or tubing / filter from main valve inlet.	Clean / unplug.
	Field test connection or tube fitting is leaking.	Tighten FTC jam nut; replace seal. Tighten all fittings.
	On F200 pilot, bushing is too far into body.	Back out bushing and check for proper blowdown.
	F300 proportional band screw is inserted too far, restricting dome pressurization.	Back out (CCW) band screw until dome pressure is able to load through pilot.
	Pilot diaphragm is leaking.	Disassemble pilot valve, remove and inspect diaphragm. Replace diaphragm.
	The pickup tube is oriented incorrectly.	Reorient the pickup tube with the port facing upstream (down).
	The pickup tube is damaged or plugged.	Inspect the pickup tube for damage. Replace if necessary. If plugged, clean and reinstall.
	Manual blowdown valve left open.	Close manual blowdown valve.
	Excessive system debris, interfering with pilot or main valve seats / seals.	Clean system or provide filtration.
	Piston or liner seal is leaking.	Disassemble valve, remove the seals and examine. Clean or replace, as necessary.
	Outlet piping is obstructed or too small.	Check outlet piping for obstructions. Pipe size should be at least the nominal size of the valve outlet.
The main valve does not open.	Pilot valve inlet tubing is plugged.	Clean / unplug line.
	Contamination between piston and liner.	Disassemble valve and examine surfaces. Clean or replace parts as necessary. Determine origin of contamination within system, and clean or provide filtration.
	Inlet line blocked.	Clear blockage in a safe manner.
	Outlet line blocked.	Clear blockage in a safe manner.
	Pilot valve is plugged.	Disassemble and clean pilot assembly.
	Increased set pressure due to auxiliary setter.	Add auxiliary setter differential to set pressure.

# INSTALLATION, OPERATION, & MAINTENANCE MANUAL



TITLE: F7000 / 8000 Series  
Pilot-Operated Safety Relief Valve

Rev. W  
Page 38 of 41

## 8.0 SOFTGOODS KITS

NOTE: Provide valve serial number(s) whenever possible when ordering softgoods kits.

### 8.1 MAIN VALVE SOFTGOODS

Valve Size	Softgoods Part Number			
	F7050 / F8050 (Elastomer-seated)		F7040 / F8040 (Plastic-seated)	
	Conventional	'IM' Construction	Conventional	'IM' Construction
1 x 2	MV75-01X02- <b>DXY</b>	MV75IM-01X02- <b>DXY</b>	MV74-01X02- <b>XY</b>	MV74IM-01X02- <b>XY</b>
1-1/2 x 3	MV75-15X03- <b>DXY</b>	MV75IM-15X03- <b>DXY</b>	MV74-15X03- <b>XY</b>	MV74IM-15X03- <b>XY</b>
2 x 3	MV75-02X03- <b>DXY</b>	MV75IM-02X03- <b>DXY</b>	MV74-02X03- <b>XY</b>	MV74IM-02X03- <b>XY</b>
3 x 4	MV75-03X04- <b>DXY</b>	MV75IM-03X04- <b>DXY</b>	MV74-03X04- <b>XY</b>	MV74IM-03X04- <b>XY</b>
4 x 6	MV75-04X06- <b>DXY</b>	----	MV74-04X06- <b>XY</b>	----
6 x 8	MV75-06X08- <b>DXY</b>	----	MV74-06X08- <b>XY</b>	----
8 x 10	MV75-08X10- <b>DXY</b>	----	MV74-08X10- <b>XY</b>	----
10 x 12	MV75-10X12- <b>DXY</b>	----	MV74-10X12- <b>XY</b>	----
12 x 16	MV75-12X16- <b>DXY</b>	----	MV74-12X16- <b>XY</b>	----

<u>X / Y = Seat / Seal Material</u>			<u>D = Seat Hardness</u>	
Code	F7040/8040 Seat (X)	F7050/8050 Seat (X) & Seals (Y) F7040/8040 Seals (Y)	Code	(F7050/8050)
T	Teflon	Teflon-encapsulated silicone	5	Soft: ≤ 50 psig
K	PCTFE / Kel-F	---	6	Medium soft: 40-80 psig
W	PI / PAI / Vespel	---	7	Medium: 51-999 psig
P	PEEK	---	9	Hard: ≥ 1000 psig
F	Ekonol-filled Teflon	---	0	"Universal": 1 each of above seats
B	---	Buna-N		<i>These pressure ranges are approximate only.</i>
V	---	Viton		
U	---	Polyurethane		
E	---	EPR / EPDM		
Z	---	Kalrez		
C	---	Chemraz		
N	---	Lo-temp nitrile		

Most common materials listed; contact Flow Safe for availability of other materials.  
Approximate pressure ranges of plastic seats shown in Section 2.2 on Page 6.

### Main Valve Softgoods Kit contents:

<u>Standard kit</u>	<u>Qty.</u>	<u>Additional items in 'IM' kit</u>	<u>Qty.</u>
Seat	1	Spool piece O-ring "1"	1
Liner seal	2	Spool piece B/U ring "1"	1
Piston seal	1	Spool piece O-ring "2"	1
Piston seal B/U ring (F7050/8050)	1	Spool piece B/U ring "2"	1
Wear ring	2 *	Spool piece O-ring "3"	1
FTC seal "A"	1 **	Spool piece B/U ring "3"	1
FTC piston seal "A"	2 **		
FTC seal "B"	1 **		
FTC piston seal "B"	1 **		
FTC crush ring "C"	1 **		

\* Wedge ring substituted for one wear ring for applicable valves (provide serial number).  
\*\* Specific FTC seal arrangement for valve can be provided based on serial number.

# INSTALLATION, OPERATION, & MAINTENANCE MANUAL



TITLE: F7000 / 8000 Series  
Pilot-Operated Safety Relief Valve

Rev. W  
Page 39 of 41

## 8.2 PILOT VALVE SOFTGOODS

<u>X / Y / Z = Pilot Seat / Seal / Diaphragm Material</u>		<u>D = Pilot Seat Hardness</u>	
Code		Code	
B	Buna-N	5	Soft: ≤ 50 psig
V	Viton	6	Medium soft: 40-80 psig
U	Polyurethane	7	Medium: 51-999 psig
E	EPR / EPDM	9	Hard: ≥ 1000 psig
Z	Kalrez	0	"Universal": 1 each of above seats
C	Chemraz		
N	Lo-temp nitrile		
T	Teflon – FEP film (diaphragms only)		<i>These pressure ranges are approximate only.</i>

*Most common materials listed; contact Flow Safe for availability of other materials.  
Seals made from other materials noted below.*

NOTE: Softgoods kits may contain extra O-rings for older part versions that may not be needed.

**F100 Softgoods Kit:** P/N F100-DHP-***DXYZ*** High pressure, direct-mount  
or F100-HP-***DXYZ*** High pressure, direct- or bracket-mount

<u>Contents (See drawing on Page 15):</u>	<u>Qty.</u>
Seat *	1
Diaphragm	1
Nozzle O-ring	1
Nozzle seal	1
Small face seal	1
Large face seal	1
Gasket (For use with Teflon diaphragm only)	1

\* Hardness per Code "D" above (Code "9" not applicable to F100 pilot)

**F200 Softgoods Kit:** P/N F200-***DXY*** Conventional style  
F200IM-***DXY*** 'IM' style

<u>Contents (See drawings on Page 17)</u>	<u>Qty.</u>
Upper / lower seat *	2
BFP O-ring	1
Upper nozzle seal	1
Small face seal	1
BFP face seal	1
Bushing seal (PTFE / Teflon)	1
'IM' bushing O-ring	1 **
Inlet port face seal	1 **

\* Hardness per Code "D" above  
\*\* For 'IM' style only

# INSTALLATION, OPERATION, & MAINTENANCE MANUAL



TITLE: F7000 / 8000 Series  
Pilot-Operated Safety Relief Valve

Rev. W  
Page 40 of 41

## 8.2 PILOT VALVE SOFTGOODS (cont'd) See Page 39 for terminal digits "D", "X", "Y", & "Z".

### F300 Softgoods Kits:

P/N F300-DI-**DXYZ** Diaphragm-style (15 - 500 psig)

<u>Contents (See drawings on Page 18):</u>	<u>Qty.</u>	
Seat *	1	
Diaphragm	1	
Small face seal	3	
Large face seal	1	
Upper sleeve seal	1	
Lower sleeve seal	1	
Upper piston seal	1	
Lower piston seal	1	
Plug seal	1	
BFP piston O-ring	1	
BFP nozzle O-ring **	1	
Diaphragm fastener seal	1	
Diaphragm support ring seal	1	
BFP seal (Teflon)	1	* Hardness per Code "D" (P. 40)
Proportional band screw seal (Teflon)	1	** on new pilots starting in 2019

P/N F300-LP-**DXY** LP piston-style (286 - 1480 psig), Conventional body (older valves)  
F300-HP-**DXY** HP piston-style (501 - 6000 psig), Conventional body

F300IM-LP-**DXY** LP piston-style (286 - 1480 psig), 'IM'-style body (older valves)  
F300IM-HP-**DXY** HP piston-style (501 - 6000 psig), 'IM'-style body

<u>Contents (See drawings on Pages 20-21):</u>	<u>Qty.</u>			
	<u>F300LP-</u>	<u>F300HP-</u>	<u>F300IM-LP-</u>	<u>F300IM-HP-</u>
Seat *	1	1	1	1
Small face seal	3	3	3	3
Large face seal	1	1	1	1
Inlet port face seal	--	--	1	1
Upper sleeve seal	1	1	1	1
Lower sleeve seal	1	1	1	1
Upper piston seal	1	2	1	2
Upper piston backup ring (Teflon)	--	2	--	2
Lower piston seal	1	1	1	1
Sense piston O-ring	1	--	1	--
Sense piston backup ring (Teflon)	1	--	1	--
Plug seal	1	1	1	1
Plug O-ring	--	--	1	1
Plug backup ring (Teflon)	--	--	1	1
BFP piston O-ring	1	1	1	1
BFP nozzle O-ring **	1	1	1	1
Diaphragm fastener seal	1	--	1	--
Diaphragm support ring seal	1	1	1	1
Adapter seal	1	1	1	1
BFP seal (Teflon)	1	1	1	1
Proportional band screw seal (Teflon)	1	1	1	1

\* Hardness per Code "D" (P. 41)

\*\* on new pilots starting in 2019

**8.2 PILOT VALVE SOFTGOODS (cont'd)** See Page 39 for terminal digits “D”, “X”, “Y”, & “Z”.

**F500 Softgoods Kits:**

P/N	<b>F500-LPS-<i>DXYZ</i></b>	LP (to 285 psig)
	<b>F500-LPT-<i>DXYZ</i></b>	LP (to 285 psig), with set point indicator

Contents (See drawings on Page 25):

	<u>F500-LPS-</u>	<u>F500-LPT-</u>
Seat *	2	2
Diaphragm	1	1
Small face seal	2	2
Large face seal	1	1
Bushing seal	1	1
Feedback piston seal	1	1
Spindle seal	1	1
Diaphragm fastener seal	1	1
BFP piston O-ring	1	1
BFP nozzle O-ring **	1	1
Diaphragm support ring seal	1	1
BFP seal (Teflon)	1	1
SPI seal	--	2
SPI bushing seal	--	1
SPI pin seal	--	1
SPI seat	--	1

\* Hardness per Code “D” (P. 41)

\*\* on new pilots starting in 2019

P/N	<b>F500-MPS-<i>7XY</i></b>	IP (286 - 999 psig), Conventional body
	<b>F500-MPT-<i>7XY</i></b>	IP (286 - 999 psig), Conventional body, with set point indicator
	<b>F500-HPS-<i>9XY</i></b>	HP (1000 - 6000 psig), Conventional body
	<b>F500-HPT-<i>9XY</i></b>	HP (1000 - 6000 psig), Conventional body, with set point indicator
	<b>F500IM-HPS-<i>9XY</i></b>	HP (1000 - 6000 psig), ‘IM’-style body
	<b>F500IM-HPT-<i>9XY</i></b>	HP (1000 - 6000 psig), ‘IM’-style body, with set point indicator

Qty.

Contents:  
(See drawings on Page 25)

	<u>F500-MPS-</u>	<u>F500-MPT-</u>	<u>F500IM-HPS-</u>	<u>F500IM-HPT-</u>
	<u>F500-HPS-</u>	<u>F500-HPT-</u>		
Seat *	2	2	2	2
Piston seal	1	1	1	1
Small face seal	2	2	2	2
Large face seal	1	1	1	1
Bushing seal	1	1	1	1
Feedback piston seal	1	1	1	1
Spindle seal	1	1	1	1
Diaphragm fastener seal	1	1	1	1
BFP piston O-ring	1	1	1	1
BFP nozzle O-ring **	1	1	1	1
Piston ring seal	1	1	1	1
BFP seal (Teflon)	1	1	1	1
Inlet port face seal	--	--	1	1
Lower bushing seal	--	--	1	1
Lower bushing seal backup ring (Teflon)	--	--	1	1
SPI seal	--	2	--	2
SPI bushing seal	--	1	--	1
SPI pin seal	--	1	--	1
SPI seat	--	1	--	1

\* Hardness per Code “D” (P. 41)

\*\* on new pilots starting in 2019