

GAS REPAIR PRODUCTS

for Natural Gas Piping Systems

Split repair sleeves, weld-on repair and reinforcing sleeves, bell-joint and full-wrap repair clamps

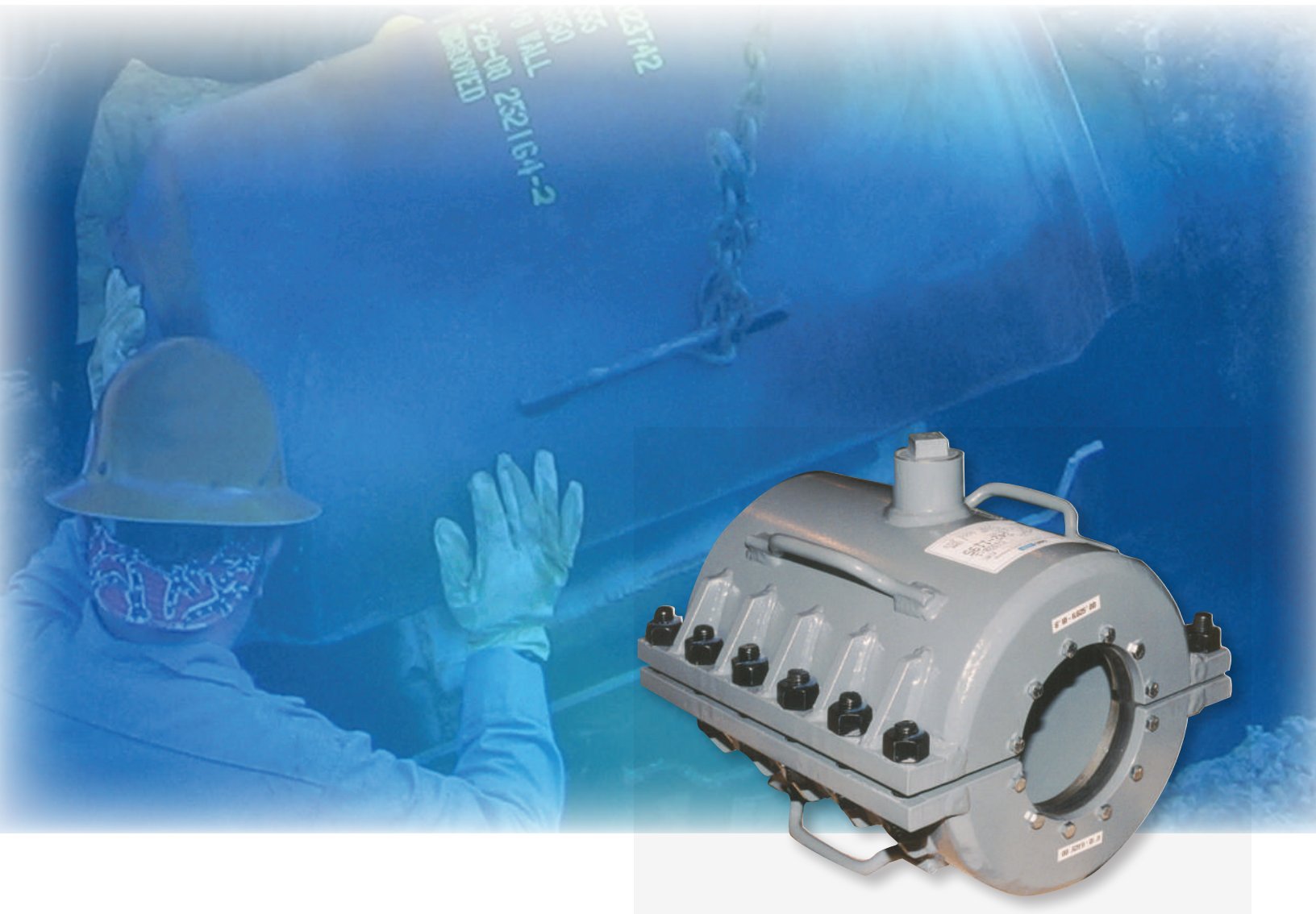



Table of Contents

Defects/Repair Product GuidelinesPages 2-4

Repair Clamps

Style 4 and 41 Collar Leak Clamps for Steel 2" - 12"	5
Style 60 and 160 Bell Joint Clamps for Cast Iron 3" - 48"	6
Style 77 Band Clamps.....	7
Style 118 Handiband Clamps 1/2" - 8"	8
Style 360 Clamps 2" - 24"	9

Repair Sleeves

Style 50 Split Repair & Tapping Sleeves	10
Style 54 and 73 Split Repair Sleeves for Steel Pipe 2", 3", 4"	11
Style 80 Ready-pack Sleeves for Cast Iron	12
Style 96 Innerpak Sleeves for High Pressure Steel - Expanded Body.....	13
Style 126 "Bell-Pack" Split Repair Sleeve for CIP.....	14
Style 110 Reinforcing Sleeves for Welded Joints.....	15-16
Style 220 Reinforcing Sleeves - Encasement	17-18
Style 220-S Reinforcing Sleeves for Small Diameter Welds & Couplings.....	18

Dresser Pipeline Solutions offers natural gas pipeline industry customers an array of high-pressure repair products and solutions, including clamps, split sleeves and weld-on reinforcing sleeves for pipeline integrity. These ruggedly built products, made of high-quality materials, are indispensable parts of a Dresser pipeline solutions portfolio that has been distinguished by industry-leading innovation and performance excellence for more than 135 years.

Our gas pipeline repair fittings are used to repair the most challenging pipe repair problems, fix pinhole leaks, cracks, and splits in steel and cast iron mains.

Dresser network of field sales representatives can make sure you get the solution that meets your pipeline repair needs. They are complemented by inside customer care specialists who understand the features, capabilities, and application requirements of each Dresser product.

Dresser Utility Solutions reserves the right to make changes in specifications and features shown herein, or discontinue the product described at any time without notice or obligation. Contact your Dresser sales representative for the most current information.

STEEL Pipeline Defects and Dresser Repair Product Options

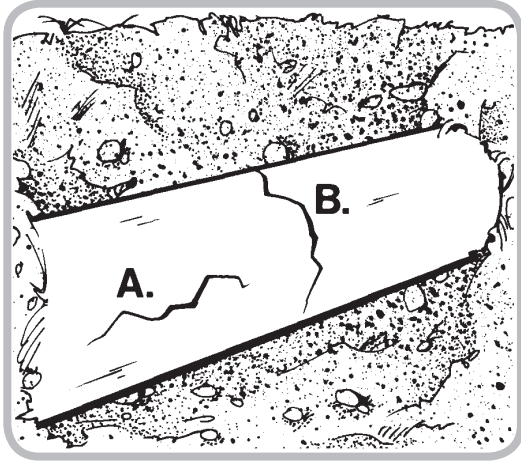

A. Longitudinal Breaks up to 8"
OR
B. Circumferential Breaks

Product	Size	Maximum Pressure
Style 54 Split Sleeve	2" - 4"	500 psi
Style 73 Split Sleeve	2"	500 psi
Style 96 Split Sleeve	6" - 24"	500 psi
Style 360 Clamp	2" - 12" 14" - 24"	See Chart, Page 9

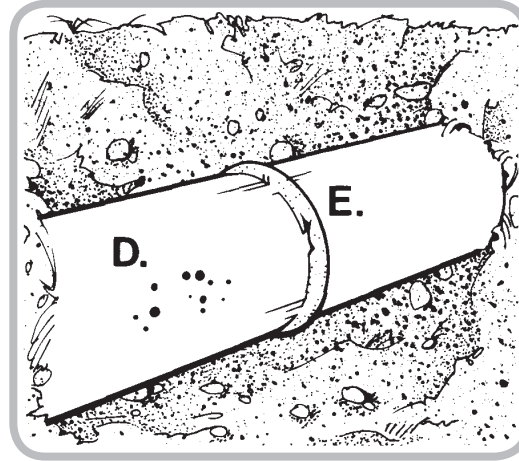

D. Small Pinhole Leaks, Splits and
Corrosion Cracks or
E. Broken Weld

Product	Size	Maximum Pressure
Style 54 Split Sleeve	2" - 4"	500 psi
Style 73 Split Sleeve	2"	500 psi
Style 77 Band Clamp	2" - 24"	150 psi
Style 118 Handiband Clamp (D only)	1/2" - 4" 6" - 8"	150 psi 100 psi
Style 360 Clamp (D only)	2" - 12" 14" - 24"	See Chart, Page 9

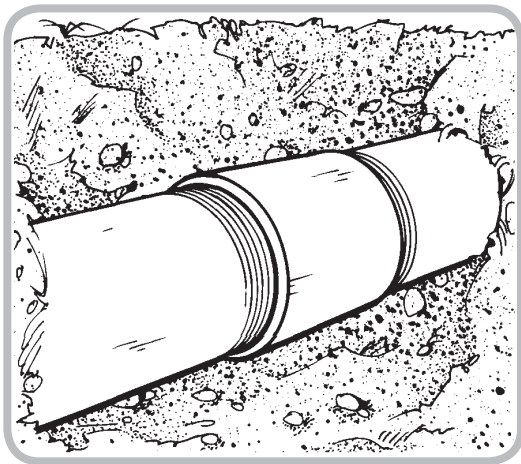

C. Leaking Collars

Product	Size	Maximum Pressure
Style 4 Collar Clamp	2" - 4"	1000 psi
Style 41 Collar Clamp	6" - 12"	1000 psi
Style 54 Split Sleeve	2" - 4"	500 psi
Style 73 Split Sleeve	2"	500 psi
Style 96 Split Sleeve	6" - 24"	500 psi

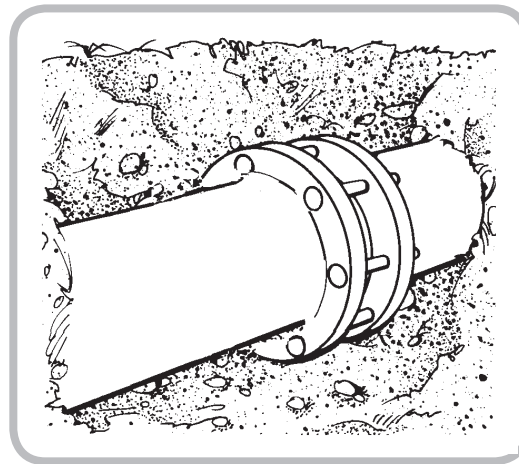

F. Leaking Coupled Joints

Product	Size	Maximum Pressure
Style 54 Split Sleeve	2" - 4"	See Chart, Page 9
Style 96 Split Sleeve	6" - 24"	500 psi
Style 220 Weld Sleeve	2" - 26"	400 - 1600 psi See chart page 18

CIP/DIP Pipeline Defects and Dresser Repair Product Options

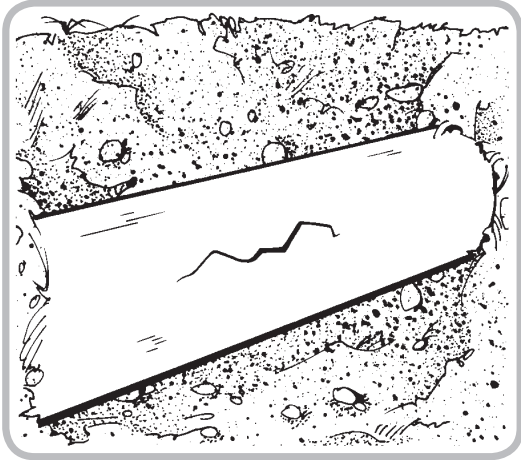

Longitudinal Breaks up to 8"

Product	Size	Maximum Pressure
Style 50 Split Sleeve	4" and above	100 psi
Style 80 Split Sleeve	4" - 8"	150 psi
Style 360 Clamp	3" - 8" 10" - 24"	See Chart, Page 9

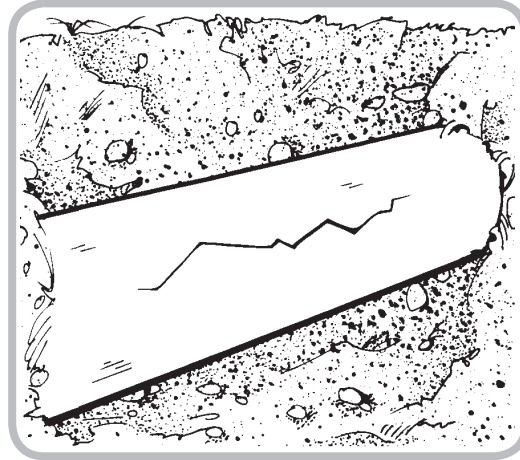

Longitudinal Breaks from 8" - 16"

Product	Size	Maximum Pressure
Style 50 Special	4" and above	100 psi
Style 360 Clamp	3" - 8" 10" - 24"	See Chart, Page 9

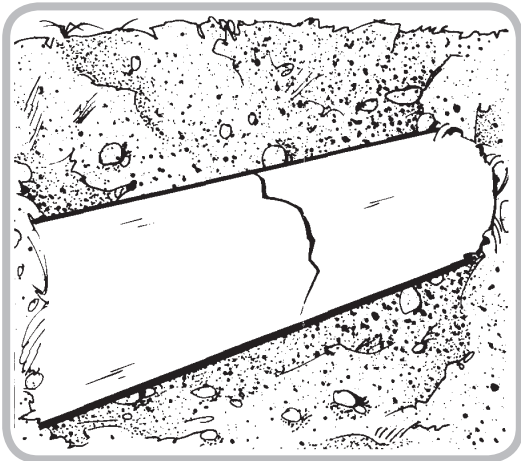

Circumferential Breaks

Product	Size	Maximum Pressure
Style 50 Split Sleeve	4" and above	100 psi
Style 80 Split Sleeve	4" - 8"	150 psi
Style 360 Clamp	3" - 8" 10" - 24"	See Chart, Page 9

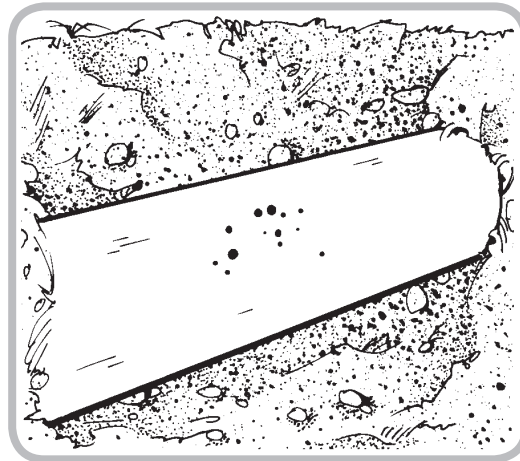

Small Pinhole or Corrosion Leaks

Product	Size	Maximum Pressure
Style 50 Split Sleeve	4" and above	100 psi
Style 80 Split Sleeve	4" - 8"	150 psi
Style 360 Clamp	3" - 8" 10" - 24"	See Chart, Page 9

CIP/DIP Pipeline Defects and Dresser Repair Product Options

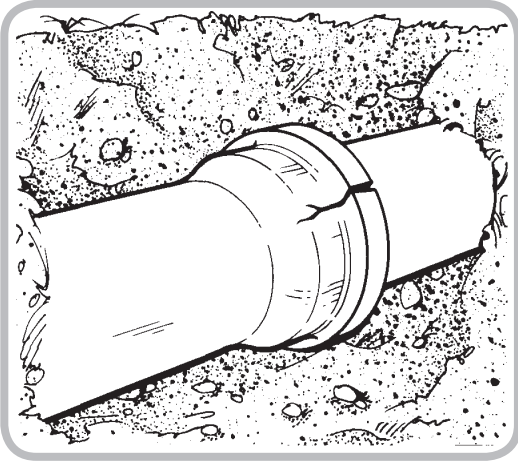

Cracked or Leaking Bell

Product	Size	Maximum Pressure
Leaking Bell: Style 60 Bell Clamp	3" - 24"	100 psi
Style 160 Bell Clamp	4" - 8" 12" & 16"	100 psi
Cracked Bell: Style 126 Split Sleeve	3" - 24"	100 psi

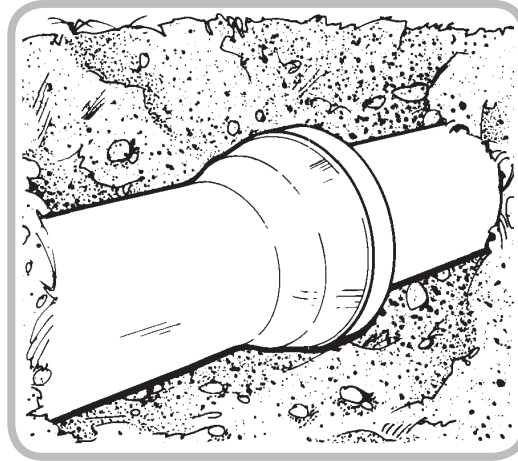

Leaking Inner-Tite Joint

Product	Size	Maximum Pressure
Style 126 Split Sleeve	8", 20", 24"	100 psi
Style 126 Special	3" - 24"	100 psi

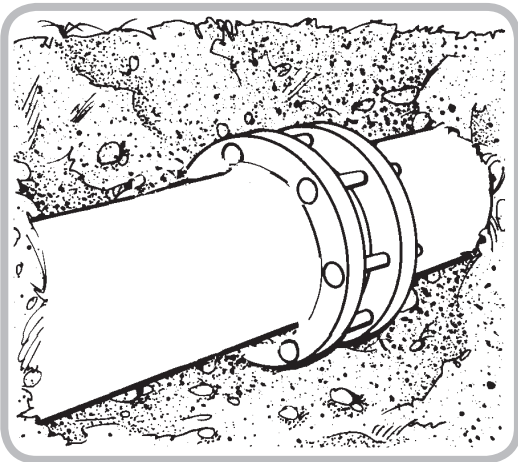

Leaking Coupled Joints

Product	Size	Maximum Pressure
Style 126 Split Sleeve	3" - 24"	100 psi

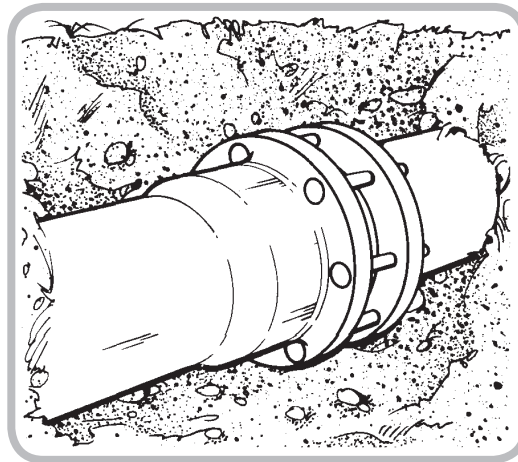

Leaking Mechanical Joints

Product	Size	Maximum Pressure
Style 126 Split Sleeve	3" - 24"	100 psi

Optional Repair

Remove defective length of pipe, insert new pipe and join with two Style 38, 40 or 700 couplings.

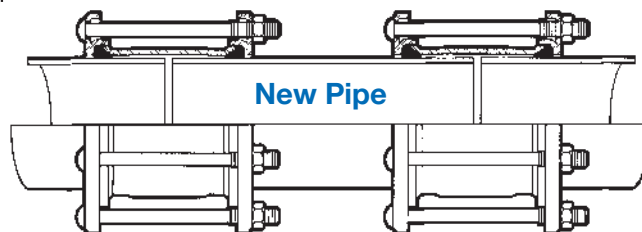

Style 4 and 41 Collar Clamps

Stops all leaks through screw collars

Dresser Style 4 and 41 clamps quickly and inexpensively stop leaks through the threads of screw collars (threaded couplings). Repairs are permanent and normally made without interrupting service or dismantling the line.

Style 4 clamps consist of two malleable split follower rings with interlocking ends on each section, two resilient split gaskets, and bolts as required for pipe sizes up to 4".

Style 41 clamps consist of the same parts, except the split follower rings are steel and are connected by steel lock links.

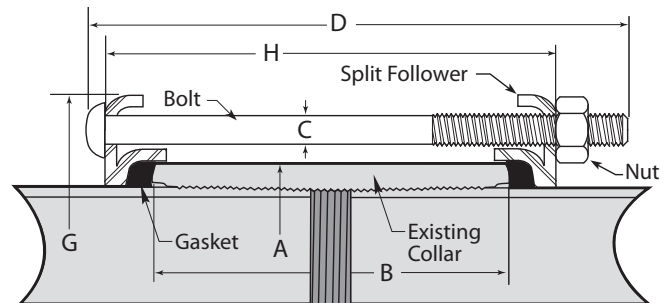
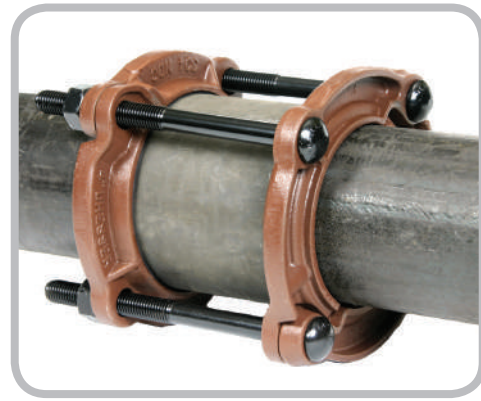

Material Specifications

Followers	Style 4 Malleable, Style 41 Steel
Bolts & Nuts	Alloy to AWWA C111/ANSI A21.11
Gasket	Grade 27 BUNA-S

Style 4 (Malleable) - Size Specifications for 2" – 4"

Nominal Size Steel (ID)	Outside Diameter (OD)	Collar Dimensions		Bolts Number Diameter & Length (C & D)	Clamp Dimensions		Gasket Section Dimensions (in)	Approximate Shipping Weight Ea. (lbs)
		Overall Diameter (A)	Overall Length (B)		Overall Diameter (G)	Overall Length (H)		
2	2.375	2.841	3.625	4 - 5/8 x 6-1/2	6-5/16	7	9/32 x 5/8	8
3	3.500	4.014	4.125	4 - 5/8 x 7-1/2	7-1/2	8	11/32 x 3/4	9
4	4.500	5.233	4.625	4 - 5/8 x 7-1/2	8-1/2	8	23/64 x 3/4	11

Style 41 (Steel) - Size Specifications for 6" ID – 12" ID

Nominal Size Steel (ID)	Outside Diameter (OD)	Collar Dimensions		Bolts Number Diameter & Length (C & D)	Clamp Dimensions		Gasket Section Dimensions (in)	Approximate Shipping Weight Ea. (lbs)
		Overall Diameter (A)	Overall Length (B)		Overall Diameter (G)	Overall Length (H)		
6	6.625	7.482	5.125	6 - 5/8 x 8-1/2	10-3/4	9-1/2	7/16 x 3/4	23
8	8.625	9.596	6.125	6 - 5/8 x 9-1/2	12-7/8	10-1/2	1/2 x 3/4	28
10	10.750	11.958	6.625	8 - 5/8 x 10-3/4	15-3/8	11	5/8 x 23/32	44
12	12.750	13.958	6.625	8 - 5/8 x 10-3/4	17-3/8	11	5/8 x 23/32	50

Dimensions are in inches unless otherwise noted.

Style 60 and 160 Bell Joint Clamps

For repair of cast iron bell and spigot joints

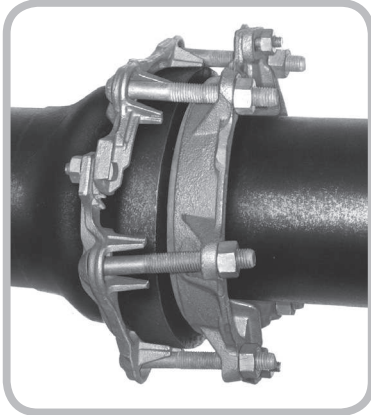

Dresser bell joint clamps permanently stop or prevent leaks through the jointing materials of cast iron bell and spigot joints. Completely adjustable to provide a close fit on both the pipe bell and spigot, one standard clamp fits virtually all makes of pipe within a nominal size.

Style 60 and 160 clamps can be quickly installed with no interruption of service. A large, special rubber compound gasket shuts off the leak when compressed as the spigot ring is drawn up and, in turn, by bolts connected to the bell ring (anchored on the bell).

Style 60 Clamp

The spigot ring of the Style 60 clamp offers a wide range of adjustment made possible by the use of clips having fillers with the same cross section of the spigot ring. Serrated ends on the bell ring sections offer a simple and effective means of adjustment, providing a positive fit for varying outside bell diameters.



Material Specifications

Rings	Cast Ductile Iron to ASTM A536
Bolts and Nuts	AWWA C111/A21.11
Spigot Ring Bolts	ASTM A-307
Clips	Ductile or Malleable Iron
Gasket	Grade 27 BUNA-S

Style 160 Clamp

The Style 160 clamp features a hinged, wraparound spigot ring design. There are no clips and the spigot sections have serrated ends that bolt together.

Style 60 and 160 - Size Specifications for 3" – 16"

Nominal Size (CIP)	Gasket Thickness x Length	Bolts Number Diam. x Length	Weight Shipping Ea. (lbs)
3	1-1/8 x 1	4 – 5/8 x 5	13
4 ¹	1-1/8 x 1	4 – 5/8 x 5	15
6 ¹	1-1/8 x 1	6 – 5/8 x 5-1/2	21
8 ¹	1-1/8 x 1	6 – 5/8 x 5-1/2	24
10	1-1/8 x 1	8 – 5/8 x 5-1/2	35
12 ¹	1-1/8 x 1	9 – 5/8 x 5-1/2	38
14	1-1/8 x 1	9 – 5/8 x 6	46
16 ¹	1-1/8 x 1	9 – 5/8 x 6	50

Style 60 and 160 - Size Specifications for 18" – 48"

Nominal Size (CIP)	Gasket Thickness x Length	Bolts Number Diam. x Length	Weight Shipping Ea. (lbs)
18	1-1/8 x 1	12 – 5/8 x 6-1/2	73
20	1-1/8 x 1	12 – 5/8 x 6-1/2	74
24	1-1/8 x 1	12 – 5/8 x 7	86
30	1-1/8 x 1	16 – 5/8 x 7	113
36	1-1/8 x 1	20 – 5/8 x 7	148
42	1-1/8 x 1	24 – 5/8 x 7-1/2	199
48	1-1/8 x 1	24 – 5/8 x 7-1/2	227

Dimensions are in inches unless otherwise noted.

¹NOTE: Style 160 Clamps may be furnished in these sizes.

Style 77 Band Clamps

For repair of pinhole leaks



Dresser Style 77 band clamps are specifically designed to provide a low cost repair for small pinholes, leaks, corroded areas and pits in straight runs of steel piping. They are suitable for virtually all working temperatures and line contents. 150 MAOP in all sizes.

Each clamp consists of a flexible, one-piece carbon steel circular band that is sprung apart to fit over the pipe, and a high-strength carbon steel bolt and nut of sufficient diameter to provide both a safety factor and protection against corrosion. The 77 clamp is available in standard steel pipe sizes from 2" through 24" with 2" or 3" wide bands. NOTE: Cone gaskets are ordered separately and must be specified when ordering the Style 77 repair clamp with three different size cone gaskets available as noted below.

Material Specifications	
Band/Lugs	AISI C1008/1010 Carbon Steel
Bolt & Nut	AWWA C111/A21.11
Gasket (77)	100% Pure Gum Rubber; 1/4" Minimum Thickness, 40 Durometer

PRESSURE RATING: 150 PSI All Sizes



Style 77 Cone Gasket		Order Separately
Gasket Number	Gasket Size (in)	Dresser Part Number
216	1-5/8"	30770001001
217	2"	30770002001
218	2-1/2"	30770004001

Style 77 Band Clamps - Size Specifications 2" – 24"

Pipe (Steel) Nominal Size (ID)	Outside Diameter (OD)	Band Thickness & Width	Bolt Diameter & Length	Approximate Ship Weight Ea. (lbs.)
2	2.375	1/16 x 2	1/2 x 4	0.84
3	3.500	1/16 x 2	1/2 x 4	0.96
4	4.500	1/16 x 2	1/2 x 5-1/2	1.3
5	5.563	1/16 x 2	1/2 x 5-1/2	1.4
6	6.625	3/32 x 3	5/8 x 6	2.8
6-5/8 CAS	7.000	3/32 x 3	5/8 x 6	2.9
8	8.625	3/32 x 3	5/8 x 6	3.4
10	10.750	3/32 x 3	5/8 x 7	4.0
11-5/8 CAS	12.000	3/32 x 3	5/8 x 7	4.3
12	12.750	3/32 x 3	5/8 x 7	4.5
14	14.000	1/8 x 3	5/8 x 8-1/4	6.2
16	16.000	1/8 x 3	5/8 x 8-1/4	6.9
18	18.000	1/8 x 3	5/8 x 8-1/4	7.5
20	20.000	1/8 x 3	5/8 x 8-1/4	8.2
24	24.000	1/8 x 3	5/8 x 8-1/4	9.6

Dimensions are in inches unless otherwise noted.

Style 118 Handiband Clamps

For quick, permanent repair of small holes in steel pipe

The Dresser Style 118 Handiband Clamp is a field-proven, low cost band-type repair clamp for quick repair of small leaks and holes in steel gas piping. Installation is fast and easy. Simply wrap the clamp around the pipe with gasket centered over the leaking area, drop the boltheads through the slotted lugs and tighten the nuts. Compression of the large size gasket seals the leak completely and permanently. Note: Style 118's do not create a 360-degree seal around the pipe.

Individual components of the Style 118 clamp are carefully engineered and constructed with lugs of ductile iron and bolts plated for long life and durability. The Style 118 clamp is made of stainless steel for corrosion resistance in lengths of 3, 6 and 12". The rubber compounded gasket offers resistance to oil, aromatic and aliphatic hydrocarbons, condensates, gasoline and natural gas. These gaskets retain their resilience for the life of the pipeline.

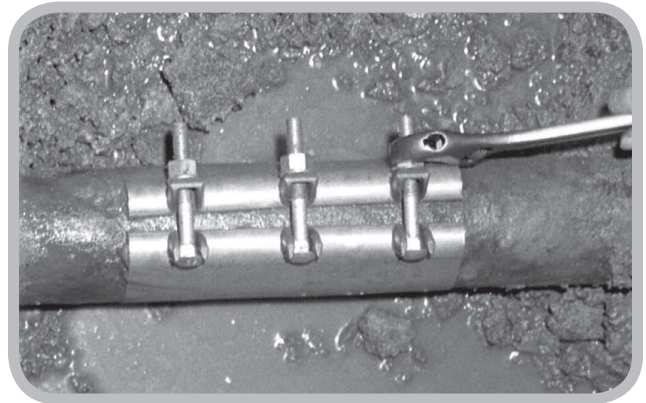
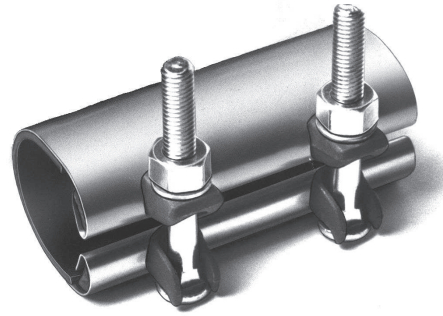

Material Specifications	
Band	Stainless Steel 18-8, Type 304
Lugs	Ductile Iron ASTM 536
Bolts & Nuts	ASTM A307
Gaskets	Gridded to Dresser specs

Pressure Ratings

1/2" thru 4"	150 psi
5" thru 8"	100 psi

Torque Recommendations	
Clamp Size	Max Torque
1/2" thru 1-1/2"	25 ft. lbs.
2" thru 8"	35 ft. lbs.

Style 118 Handiband Repair Clamp - Size Specifications for 1/2" thru 8"; Band Lengths Options of 3", 6" and 12"

Nominal Size (ID)	Outside Diameter (OD)	Overall Length (in)	Quantity per Package	Weight Ea. (lbs)
1/2	.840	3	20	.50
1/2	.840	6	10	1.00
3/4	1.050	3	16	.60
3/4	1.050	6	8	1.10
1	1.315	3	16	.60
1	1.315	6	8	1.20
1-1/4	1.660	3	12	.90
1-1/4	1.660	6	6	1.70
1-1/2	1.900	3	12	.90
1-1/2	1.900	6	6	1.80
2	2.375	3	8	1.11
2	2.375	6	4	2.30
2	2.375	12	2	4.50
2-1/2	2.875	3	8	1.20
2-1/2	2.875	6	2	2.30

Nominal Size (ID)	Outside Diameter (OD)	Overall Length (in)	Quantity per Package	Weight Ea. (lbs)
3	3.500	3	6	1.20
3	3.500	6	4	2.40
3	3.500	12	2	4.80
3-1/2	4.000	3	6	1.50
3-1/2	4.000	6	4	3.00
4	4.500	3	6	1.50
4	4.500	6	4	3.10
4	4.500	12	2	6.30
5	5.563	3	6	1.60
5	5.563	6	4	3.21
6	6.625	3	6	1.80
6	6.625	6	4	3.60
6	6.625	12	1	7.20
8	8.625	3	6	2.00
8	8.625	6	4	4.00
8	8.625	12	1	7.00

Dimensions are in inches unless otherwise noted.

NOTE: All orders for unpackaged sizes and for broken carton quantities will be randomly packaged

Style 360 Repair Clamps

For fast repair of leaks in cast/ductile and steel mains

The Dresser Style 360 repair clamp offers simplicity and ease of installation. Just wrap the clamp around the pipe, drop the bolts in place and tighten. It's that simple! Moreover, special one-inch long nuts allow the use of a standard deep socket wrench for complete tightening. In the popular 7.5 inch clamp width, there is also a third bolt, so the middle bolt and nut can be used to pre-tighten the clamp. Additionally, the smaller clamps feature a flexible band, which means less holding force is required while tightening.

With the Style 360 clamp, you can repair holes, breaks and splits in the pipeline...You can even use it where pipe ends are separated, or where ends are deflected up to 4 degrees or 1/8 inch. Clamp features include a tapered gasket with a gridded design, and the spanner is molded flush with the gasket to prevent "hang up." The Style 360 clamp has a stainless band, lugs of rugged ductile iron and bolts of corrosion-resistant Dresserloy.

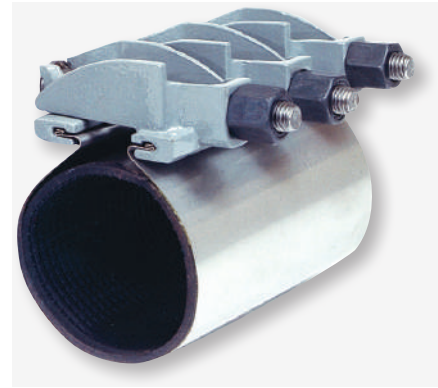

Style 360 Clamp Features:

- One-inch long nuts allow tightening with standard deep socket wrench.
- Drop-in bolts - No need to remove bolts in the ditch. No loose parts to misplace.
- Multi-band clamp - Features a multi-band design in the 14" through 24" sizes. Clamp is packaged and shipped "in the flat," meaning the bands are not formed to the radius of the pipe. Reduces storage space and installation time, and has twice the adjustment range of the single-band clamp.

Style 360 Repair Clamp - Size Specifications

Range of Fit (OD)	Clamp Widths	Max. psi	Range of Fit (OD)	Clamp Widths	Max. psi	
2.35 - 2.63	7-1/2, 12-1/2	125	11.04 - 11.44	7-1/2, 12-1/2, 15, 20, 30	95	
2.70 - 3.00	0.024 Thick Band		11.34 - 11.74		85	
2.97 - 3.25			11.75 - 12.15		85	
3.46 - 3.70	7-1/2,	12.00 - 12.40	85			
3.73 - 4.00	12-1/2, 15,	12.62 - 13.02	75			
3.96 - 4.25		20	13.10 - 13.50	75		
4.45 - 4.86	0.024" Thick Band	125	13.40 - 13.80	0.036" Thick Band	65	
4.74 - 5.14			13.70 - 14.10		65	
4.95 - 5.35			14.00 - 14.40	65		
5.22 - 5.62		125	2 Band Sizes		105	
5.95 - 6.35		125	14.38 - 15.13		100	
6.56 - 6.96	7-1/2,	125	15.07 - 15.82	0.048" Thick Multi-Band	90	
6.84 - 7.24		125	15.92 - 16.67		85	
7.05 - 7.45	12-1/2, 15,	125	16.56 - 17.31		20, 30	80
7.95 - 8.35		125	17.15 - 17.90			75
8.54 - 8.94	20, 30	125	17.82 - 18.57		70	
8.99 - 9.39		125	18.46 - 19.21		65	
9.27 - 9.67	0.024" Thick Band	115	19.23 - 19.98		60	
9.68 - 10.08		115	19.90 - 20.65		55	
9.70 - 10.10		115	20.70 - 21.45		50	
10.64 - 11.04		95	21.52 - 22.27		50	
			22.12 - 22.87	45		
			22.90 - 23.65			

Dimensions are in inches unless otherwise noted.

NOTE: On any given installation, the pressure capability of the clamps is influenced by the type and extent of the damage, service conditions, environmental conditions and installation workmanship.

Material Specifications	
Band	AISI Type 304 Stainless Steel
Lugs	Ductile Iron
Nuts	AWWA C111/A21.11
Bolts	AWWA C111/A21.11
Spanner	AISI Type 304 Stainless Steel
Gasket	Gridded Surface to Dresser Specs, 55 Durometer

Style 50 Split Repair Sleeves

Dual purpose sleeve for emergency repair or hot tapping CIP

The versatile Dresser Style 50 split repair sleeve can provide a safe, efficient method of hot tapping cast iron pipe under pressure. It can also be ordered without the pipe branch and serve as an emergency repair sleeve, eliminating the necessity of stocking separate tapping and repair sleeves.

Style 50 sleeves can be furnished with any size threaded, flanged or plain-end tapping branch, custom-fabricated at the plant to meet any requirement. Each sleeve can accommodate several branch sizes, permitting further inventory reductions. Branches can be supplied with special taps for insertion of bagging equipment when low pressure tapping is performed.

Style 50 Sleeve Features:

- Fabricated from steel and insulated from main to meet DOT standards
- Factory-assembled to facilitate handling, storage and ease of installation
- Sleeve halves are match-marked to assure a proper fit
- No service interruptions during the installation procedure
- Deflection and line stresses absorbed when used as a repair device for complete breaks
- Time-proven sealing principle and furnished with Dresser gray epoxy coating as standard
- Sleeve can be pressure tested to ensure sealing performance prior to tapping

Style 50 Custom Fabricated Sleeves

Contact Dresser Inside Sales for your custom branch service outlet applications

Hot Taps

The Dresser Style 50 Sleeve is easily integrated with Intervention Technologies LS2 flange fittings to provide an efficient hot tap of cast iron pipe under pressure. Custom fabrication with branch service outlets can also be coupled with Dresser bolted couplings for all your PE connection requirements.

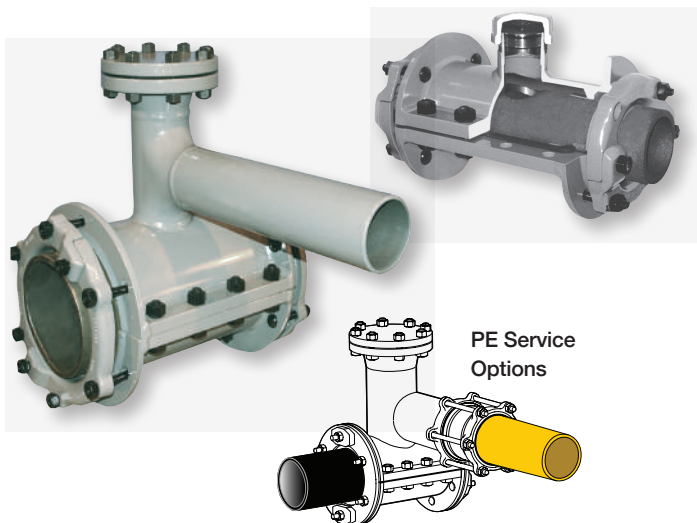

Style 50 Split Repair Sleeve for Cast Iron Pipe Size Specifications for 6" - 24"

Nominal Size ¹ (CIP)	Outside Diameter (OD)	Length Between End Gaskets	MAOP (psi)
6	6.90	11-1/2	100
8	9.05	12	100
10	11.10	17-1/4	100
12	13.20	18-1/4	100
16	17.40	21-3/4	100
20	21.60	24	100
24	25.80	29	100

Dimensions are in inches unless otherwise noted.

¹ Style 50 sleeves may be furnished in sizes up to 48"

Material Specifications

Consult Factory per Application

Style 50 with Service Branch Outlet

Size Specifications for 6" - 24"

Nom. Size ¹ (CIP)	Outside Diameter (OD)	Length Between End Gaskets	Maximum Branch Size	Max Operating Pressure ² (psi)
6	6.90	10-1/2	4 IPS	100
8	9.05	12	6 IPS	100
10	11.10	17-1/4	6 IPS	100
12	13.20	18-1/4	8 IPS	100
16	17.40	21-3/4	12 IPS	100
20	21.60	24	16 IPS	100
24	25.80	29	16 IPS	100

Dimensions are in inches unless otherwise noted.

¹ Style 50 sleeves may be furnished in sizes up to 48" or larger.

² Other pressures available on request

Style 54 and 73 Cast Split Sleeves

For repair of defective joints on 2", 3" and 4" steel pipe



Dresser Style 54 cast split sleeves are designed to completely enclose and repair defective screw collars, plain or butt bell and spigot joints and double-bell circumferential welded joints. Style 54 sleeves can also be used to repair holes and splits up to 8" on steel pipe without service interruptions, and are vented for installation under pressure.

Style 54 sleeves are of rugged construction to permit safe repairs on high-pressure gas and oil transmission pipelines up to 500 PSI. Each sleeve is air-tested with 60 psi air pressure and 1000 psi hydrostatic pressure before shipment. The sleeves are shipped factory-assembled, with the end parts packed inside the sleeve body with the installation instructions.

Style 73 cast repair sleeves are similar in construction and provide a fast, permanent repair on steel lines where moderate pressures are involved.

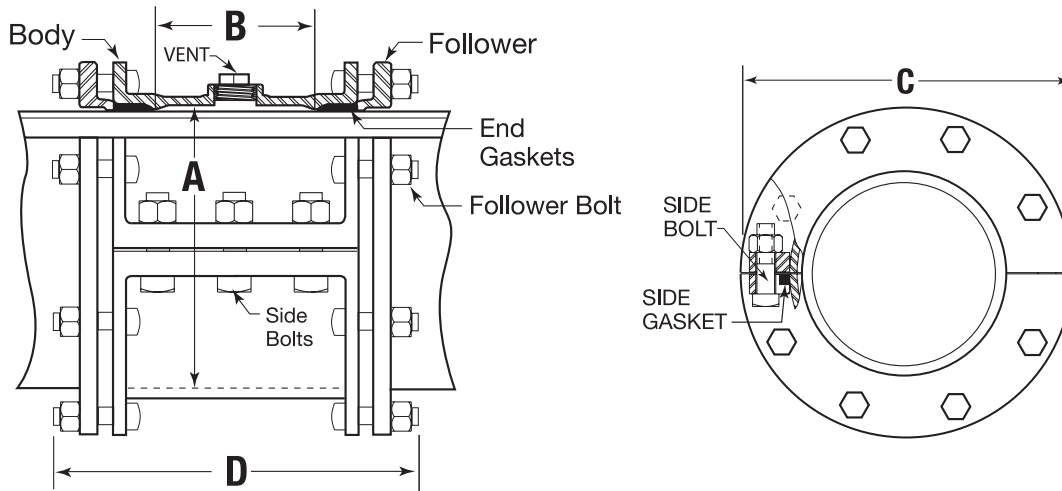

Style 54 Sleeves - Size Specifications for Steel Pipe (500 psi)

Nom. Size Steel (ID)	Outside Diam. (OD)	End Bolts No/Diameter x Length	Side Bolts No/Diameter x Length	Inside Dimension Diameter / Length		Overall Dimension Diameter / Length (in)		Vent Size (IPS)	Weight Ea. (lbs)
				(A)	(B)	(C)	(D)		
2	2.375	8 - 1/2 x 4	10 - 3/4 x 2-1/2	6-7/8	11	11-3/4	20-1/8	1	75
3	3.500	8 - 5/8 x 4	10 - 3/4 x 2-1/2	8	11	13	20-1/8	1-1/4	85
4	4.500	8 - 5/8 x 4	12 - 3/4 x 3	10-1/2	14-1/4	16-1/8	25-1/2	2	154

Style 73 Sleeve - Size Specifications for Steel Pipe (500 psi)

Nom. Size Steel (ID)	Outside Diam. (OD)	End Bolts No/Diameter x Length	Side Bolts No/Diameter x Length	Inside Dimension Diameter / Length		Overall Dimension Diameter / Length (in)		Vent Size (IPS)	Weight Ea. (lbs)
				(A)	(B)	(C)	(D)		
2	2.375	8 - 6/16 x 3-1/2	6 - 5/8 x 2-1/2	3-15/16	7	8 - 1/2	16-1/2	1	47

Dimensions are in inches unless otherwise noted.

Style 80 Split “Ready-Pack” Sleeves

For repairs on cast iron pipe

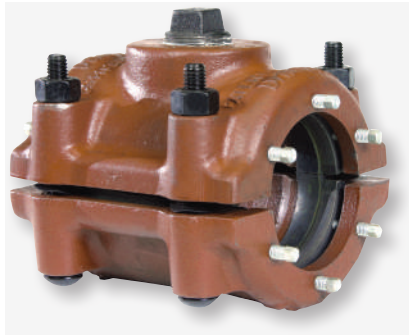

Dresser Style 80 split “ready-pack” sleeves are used to enclose and permanently repair breaks, splits and holes in cast iron pipe. With vent sizes 1” thru 3”, Style 80 sleeves can also be used as an efficient, low-cost tapping sleeve for branch service connections.

Style 80 sleeve bodies are cast from close-grained gray iron. Steel follower rings on each end are completely enclosed in the sleeve body. Carbon steel set screws are drawn up against the follower ring to compress the gasket, creating total circumferential sealing on the pipe. Side bolts, which are fully enclosed within the sleeve body to prevent corrosion, are tightened to compress side gaskets and provide a complete leakproof seal.

Style 80 sleeves are recommended for all customary pressures where pipe wall thickness is in conformity with specifications for standard cast iron pipe.

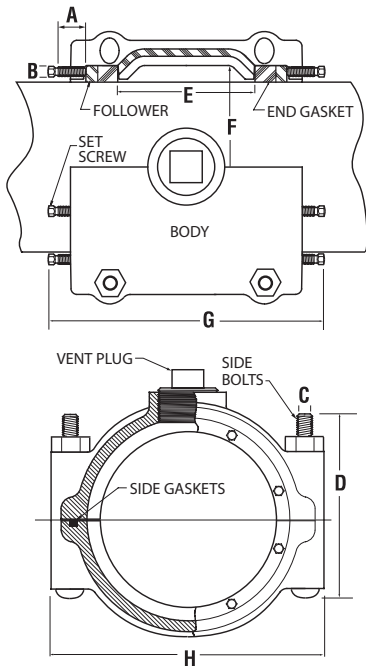

Material Specifications

Body	Cast Iron
Vent Plug	Forged Steel to ASTM A105 or Cast to ASTM A126-42 Class A
Follower Rings	Cold-formed carbon steel
Bolts & Nuts	Alloy to AWWA C111/ANSI A21.11
Gaskets	Grade 29 Spec 328

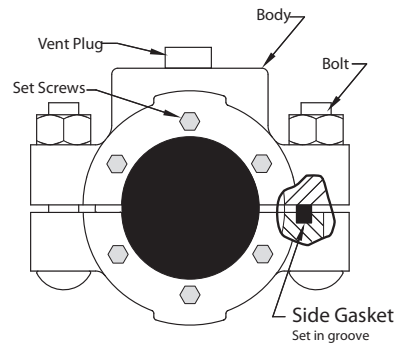

Style 80 Split Sleeves - Size Specifications for Cast Iron Pipe (All Sizes 150 MAOP)

Nom. Pipe Size (CIP)	Range of Fit (OD)	End Screws Number Diam. x Length A & B	Side Bolts Number Dia. x Length C & D	End Gasket Section Dimen. (in)	Side Gasket Section Dimen. (in)	Inside Dimension ¹ Diam. (E) Length (F)		Overall Dimension Diam. (G) Length (H)		Vent Diam. (in)	Weight Ea. (lbs)
						(E)	(F)	(G)	(H)		
3	3.75-4.00	12- 3/8X1	4-5/8 x 5-1/2	5/8 x 3/4	5/16 x 1/2	4	5-5/32	9-3/8	7-15/16	1-1/4 - 2	40
4	4.74-4.99	12- 3/8X1	4-5/8 x 5-1/2	5/8 x 3/4	5/16 x 1/2	4	6-5/32	9-3/8	8-15/16	1 - 3	45
4 ²			2-5/8 x 5-1/2						10-7/8	2 - 3	55
6 ²	6.84-7.09	16- 3/8X1	4-5/8 x 6-1/2	5/8 x 3/4	5/16 x 1/2	4	8-1/4	9-5/16	11-7/8	2 - 3	70
			2-5/8 x 5-1/2								
8 ²	8.99-9.24	20- 3/8X1	4 5/8 x 7-1/2	5/8 x 3/16	5/16 x 1/2	7	10-13/32	12-1/2	11-7/8	2 - 3	100
			2 5/8 x 5-1/2								

Dimensions are in inches unless otherwise noted.

¹ Inside Dimension “E” as indicated in cross section drawing, is distance between inside of end gaskets. This length is equal to or greater than found between calking spaces in foundry “splits” as shown in AGA Standards Specifications for Service Sleeves.

² Long Pattern Design. Consult factory for specification details. Style 80 long body sleeves have six side bolts.

Style 96 Split Repair Sleeves

Expanded body split sleeve for repairs on steel pipe

Dresser Style 96 split repair sleeves offer an expanded body for repairing coupled or mechanical joints on high-pressure steel transmission piping systems from 500 psi to 1500 PSI .

Style 96 sleeves are fabricated from high-quality carbon steel and come completely factory-assembled for quick installation. All sleeves are vented for installation under pressure without service interruptions.



Pressure Ratings		Material Specifications	
ANSI 150 to 500 PSI Standard Designs		Body Halves	Weldable steel suitable for the particular application to ASTM A36 or equivalent
Up to 1,500 PSI On Application		Follower	Carbon Steel AISI C1015
See Specification Chart Below		Cap Screws	Heat-treated Carbon Steel C1038
Temperature Ratings	-20° F to +150° F for all sizes	Bolts/Studs/Nuts	Meet ASTM A193 Grade B7 /ASTM A 194 Grade 2h or SAE Grade 8
		Gaskets	Dresser Grade 29
		Coatings	Provided RED-D as standard: ALCLAD™ fusion-bonded epoxy optional

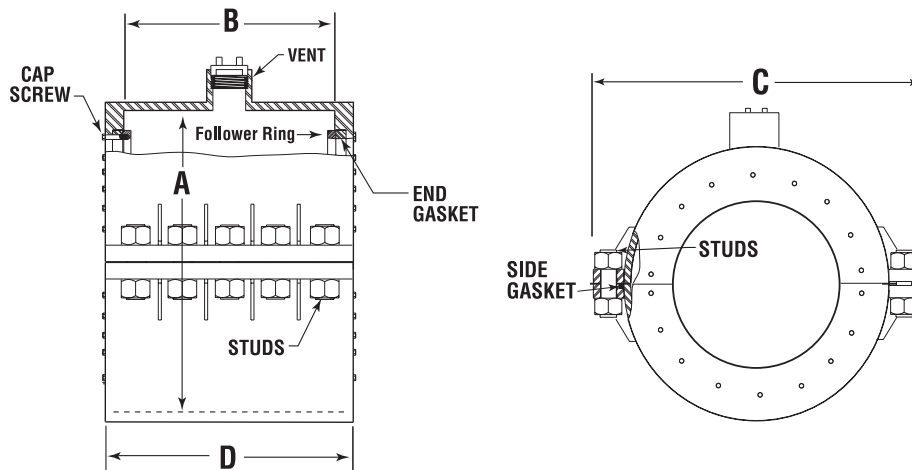

Style 96 Split Sleeves - Dimension Specifications for Steel Pipe Sizes 6" - 24"

Pipe (Steel)		ANSI 150 to 500 PSI				ANSI 300 to 1000 PSI				ANSI 600 to 1500 PSI				Vent Diam. (in)
Nom. Size (in)	Out-side Diam. (OD)	Inside Dim.		Overall Dim.		Inside Dim.		Overall Dim.		Inside Dim.		Overall Dim.		
		(A)	(B)	(C)	(D)	(A)	(B)	(C)	(D)	(A)	(B)	(C)	(D)	
6	6.625	12-5/8	14	17-7/8	18-3/8	12-5/8	13-3/4	19-5/8	22-3/4	12-5/8	15-1/4	20-5/8	25	2
8	8.625	14-5/8	14	19-7/8	18-3/8	10-7/8	13-3/4	19-5/8	22-3/4	14-5/8	15-1/4	22-5/8	25	2
10	10.750	16-3/4	14-1/4	22	18-7/8	14-5/8	16-3/8	24-1/4	26-7/8	16-3/4	16-3/8	25-1/8	27	3
12	12.750	18-3/4	14-1/4	24-1/4	20-3/4	16-3/4	16-3/8	26-1/4	22-7/8	18-3/4	18	31	31-1/2	3
14	14	20	14-1/4	25-1/2	20-3/4	18-3/4	16	29-1/2	28	20	18	32	31-1/2	3
16	16	20	14-1/4	27-1/2	20-3/4	20	18	32	29-1/2	22	18	34	31-1/2	4
18	18	20	14-1/4	29-1/2	20-3/4	22	20-1/4	35-3/8	34	24	18	36	31-1/2	4
20	20	26	14-1/4	32-1/4	20-3/4	24	15-1/4	35	27	26	18	38	31-1/2	4
22	22	28	14-1/4	34-1/4	20-3/4	26	16-1/2	40-3/8	32	28	18	38	31-1/2	4
24	24	30	16	36-1/8	22-1/2	28	16-1/2	42	32	29-5/8	18	42	35	4

Dimensions are in inches unless otherwise noted.

Style 126 Bell-Pack Repair Sleeves

For repair of broken cast iron bell and spigot joints

Pipeline maintenance personnel avoid pipeline shutdowns and expensive, temporary makeshift repairs by installing the Dresser Style 126 Bell-Pack repair sleeve for a fast, economical and permanent repair. A sleeve of lighter weight and compact design, the Style 126 provides maximum inside dimension clearance for repairing split cast iron bells and leaking mechanical joints.

Built to rigid Dresser specifications, Style 126 repair sleeves provide the time-proven features of the Dresser rubber-packed gasket sealing design. Side bolts enclosed within the sleeve body, are then tightened to compress side gaskets providing a complete, permanent leakproof seal.

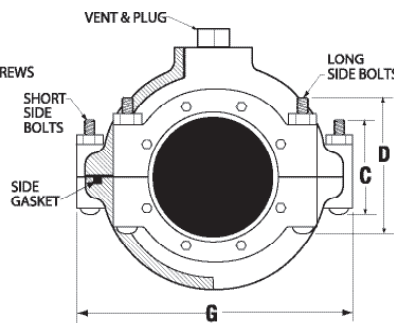
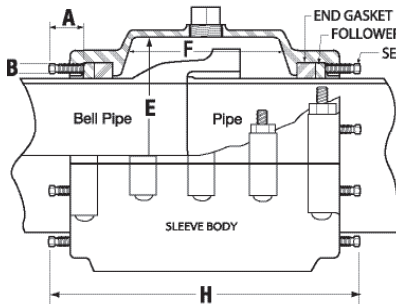
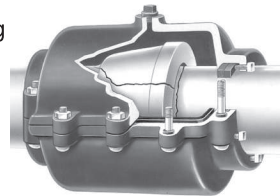

Material Specifications

Body	Cast or malleable iron through 8" CIP. Larger sizes are special designs fabricated steel plate and bar.
Vent Plug	Forged Steel to ASTM A105 or Cast to ASTM A126-42 Class A
Followers	Cold-formed carbon steel
Bolts	Alloy to AWWA C111/ANSI A21.11
Gaskets	Grade 29
Set Screws	Carbon Steel, Cadmium Plated
Coating	Dresser RED-D shopcoat standard; Fusion bonded epoxy optional

Style 126 Repair Sleeve - Specifications for Cast Iron Sizes 4"- 24" (100 PSI)

Nom. Size (CIP)	Outside Diam. (OD)	End Screws ¹ Dia. x Length (A) & (B)	Short Side Bolts Number ² Dia. x Length	Long Side Bolts Number Dia. x Length	Inside Dimension Diameter Length		Overall Dimension Diameter Length		Vent ³ Diam. (in)	Weight Approx. Ea. (lbs)
					(E)	(F)	(G)	(H)		
4	4.800	12-3/8 x 1	6-5/8 x 4	4-5/8 x 6	10	12	14-1/2	19-1/16	1	136
4	5.000	12-3/8 x 1	6-5/8 x 4	4-5/8 x 6	10	12	14-1/2	19-1/16	1	136
6	6.900	16-3/8 x 1	6-5/8 x 5	4-5/8 x 7	12-1/2	12	17-1/8	19-1/16	1	185
6	7.100	16-3/8 x 1	6-5/8 x 7	4-5/8 x 7	12-1/2	12	17-1/8	19-1/16	1	185
8	9.050	20-3/8 x 1-1/4	6-5/8 x 5	4-5/8 x 7-1/2	15-1/2	12-3/8	20-1/4	19-3/16	1	265
8	9.300	20-3/8 x 1-1/4	6-5/8 x 5	4-5/8 x 7-1/2	15-1/2	12-3/8	20-1/4	19-3/16	1	265
10	11.100	24-7/16 x 2-1/4	12-3/4 x 4	—	16-5/8	13-1/2	22-3/8	18-5/8	1	300
10	11.400	24-7/16 x 2-1/4	12-3/4 x 4	—	16-5/8	13-1/2	22-3/8	18-5/8	1	300
12	13.200	28-7/16 x 2-1/4	12-7/8 x 4	—	18-3/4	13-1/2	24-1/2	18-5/8	1	335
12	13.500	28-7/16 x 2-1/4	12-7/8 x 4	—	18-3/4	13-1/2	24-1/2	18-5/8	1	335
16	17.400	32-7/16 x 2-1/4	14-7/8 x 4	—	24	16	30	21-1/8	2	554
16	17.800	32-7/16 x 2-1/4	14-7/8 x 4	—	24	16	30	21-1/8	2	554
20	21.600	40-7/16 x 2-1/4	14-1 x 4	—	30	17	36	22-1/8	3	770
20	22.060	40-7/16 x 2-1/4	14-1 x 4	—	30	17	36	22-1/8	3	770
24	25.800	48-7/16 x 2-1/4	14-1 x 4	—	33-7/8	18	39-7/8	23-1/8	3	853
24	26.320	48-7/16 x 2-1/4	14-1 x 4	—	33-7/8	18	39-7/8	23-1/8	3	853

Dimensions are in inches unless otherwise noted.

¹ End Screws are high-grade steel, and have square heads, 3/8" across flats.

² Side Bolts are high-grade steel with trackheads and rolled threads through 8" size. Larger sizes are supplied with galvanized machine bolts.

³ Vent supplied with ASME B1.20.1 pipe threads.

⁴ Fabricated Style 126 sleeves have end seal design similar to Style 96.

Style 110 Weld-On Reinforcing Sleeves

Split repair and integrity reinforcement sleeve for repair of welded joints

Pipeline engineers assure the safety of field joints by installing Dresser Style 110 reinforcing sleeves on welded joints where special precautions are required. Style 110 sleeves can be used on defective 'trouble spots' on piping systems, at highway, river and railroad crossings, at overbends, at tie-ins, in marshy ground, near buildings, and other places where special precautions are necessary.

The Style 110 sleeve lends itself to field welding without preheating, using ordinary field welding procedures. All sleeves are factory prepared with standard welding bevel, machine flame cut for uniformity and ease of welding, and come with a drilled vent hole to preclude pressure buildup between sleeve and pipe.

Built to rigid Dresser specifications, Style 110 sleeves have a minimum yield strength of 50,000 psi and an ultimate strength of 70,000 psi. Style 110 sleeves are supplied in all standard sizes, lengths and thicknesses (see charts below). Custom-built larger sizes and lengths available upon request.

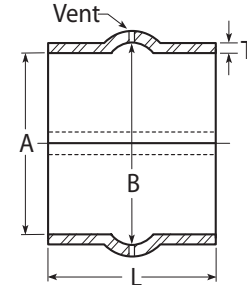

Style 110 Sleeves - Dimension specifications for nominal sizes 4" thru 30" and lengths 6" - 24" (with vent)

Nom. Size (in)	ID Diam. 'A' Pipe OD (in)	Diam. 'B' (in)	Length 'L' (in)	Thickness 'T' (in)	Approx. Ship Wt. (lbs)
4	4-1/2	5-3/8	4	5/16	5.5
6	6-5/8	7-1/2	6	3/8	16
8	8-5/8	9-1/2	6	3/8	19
8	5/8	9-1/2	8	3/8	27
8	8-5/8	9-1/2	6	1/2	26
8	8-5/8	9-1/2	8	1/2	35
10	10-3/4	11-5/8	6	3/8	23
10	10-3/4	11-5/8	10	3/8	38
10	10-3/4	11-5/8	6	1/2	31
10	10-3/4	11-5/8	10	1/2	50
12	12-3/4	14-1/4	6	3/8	27
			9	3/8	40
			12	3/8	45
			6	1/2	36
			9	1/2	55
			12	1/2	74
14	14	15-1/2	6	3/8	30
			9	3/8	45
			14	3/8	70
			6	1/2	40
			9	1/2	60
			14	1/2	94
16	16	17-1/2	6	3/8	35
			9	3/8	52
			12	3/8	68
			16	3/8	90
			6	1/2	46
			9	1/2	70
			12	1/2	90
			16	1/2	120
18	18	19-1/2	6	3/8	39
			9	3/8	58
			12	3/8	77
			18	3/8	114
			6	1/2	51
			9	1/2	78
			12	1/2	101
			18	1/2	152
20	20	21-1/2	6	3/8	43
			9	3/8	64
			12	3/8	84
			20	3/8	139

Nom. Size (in)	ID Diam. 'A' Pipe OD (in)	Diam. 'B' (in)	Length 'L' (in)	Thickness 'T' (in)	Approx. Ship Wt. (lbs)
20	20	21-1/2	6	1/2	58
			9	1/2	86
			12	1/2	112
			20	1/2	186
			21	1/2	195
22	22	23-1/3	6	3/8	47
			9	3/8	70
			12	3/8	92
			22	3/8	166
			6	1/2	64
			9	1/2	94
			12	1/2	123
			22	1/2	230
24	24	25-1/2	6	3/8	51
			9	3/8	76
			12	3/8	100
			16	3/8	133
			24	3/8	198
			6	1/2	69
			9	1/2	101
			12	1/2	133
			16	1/2	177
			24	1/2	265
26	26	27-1/2	6	3/8	56
			9	3/8	82
			12	3/8	109
			16	3/8	143
			26	3/8	232
			6	1/2	75
			9	1/2	110
			12	1/2	144
			16	1/2	190
			26	1/2	310
30	30	31-1/2	6	3/8	64
			9	3/8	95
			12	3/8	125
			16	3/8	164
			30	3/8	310
			6	1/2	85
			9	1/2	127
			12	1/2	166
			16	1/2	220
			30	1/2	410

Dimensions are in inches unless otherwise noted.

NOTE: Larger diameters, higher pressure and metric sizes may be furnished upon request. Please consult factory.

Style 110 Repair & Reinforcing Sleeves

Style 110 Sleeves - (Maximum Operating Pressure by Location)

Pipe Size (OD) x Wall Thickness	Class 1	Class 2	Class 3	Class 4
4-1/2" OD x 5/16" Wall	3130 G	2605 G	2170 G	1735 G
6-5/8" OD x 3/8" Wall	2615 G	2180 G	1815 G	1450 G
8-5/8" OD x 3/8" Wall	2105 G	1755 G	1460 G	1170 G
8-5/8" OD x 1/2" Wall	2704 G	2285 G	1900 G	1520 G
10-3/4" OD x 3/8" Wall	1745 G	1450 G	1210 G	965 G
10-3/4" OD x 1/2" Wall	2280 G	1900 G	1580 G	1265 G
12-3/4" OD x 3/8" Wall	1440 G	1200 G	1000 G	800 G
12-3/4" OD x 1/2" Wall	1885 G	1570 G	1310 G	1045 G
14" OD x 3/8" Wall	1325 G	1105 G	920 G	735 G
14" OD x 1/2" Wall	1745 G	1450 G	1210 G	965 G
16" OD x 3/8" Wall	1180 G	985 G	820 G	655 G
16" OD x 1/2" Wall	1555 G	1295 G	1080 G	860 G
18" OD x 3/8" Wall	1065 G	885 G	740 G	590 G
18" OD x 1/2" Wall	1400 G	1170 G	975 G	780 G
20" OD x 3/8" Wall	970 G	805 G	670 G	535 G
20" OD x 1/2" Wall	1275 G	1065 G	885 G	710 G
22" OD x 3/8" Wall	890 G	740 G	615 G	490 G
22" OD x 1/2" Wall	1175 G	975 G	815 G	650 G
24" OD x 3/8" Wall	820 G	685 G	570 G	455 G
24" OD x 1/2" Wall	1085 G	905 G	750 G	600 G
26" OD x 3/8" Wall	760 G	635 G	530 G	420 G
26" OD x 1/2" Wall	1010 G	840 G	700 G	560 G
30" OD x 3/8" Wall	665 G	555 G	465 G	370 G

Material Specifications

Body High strength, low carbon steel meeting ASTM A572 GR 50

Style 110 Ratings

Yield Strength 50,000 psi minimum

Temperature Ratings -20° F to +150°

Dimensions are in inches unless otherwise noted.

NOTE: Style 110 sleeve design pressure for class location has been determined using the formula shown in DOT Regulation 192, Section 192.105, assuming an 80% joint factor for the longitudinal field weld.

For Oil Applications Refer to Class 1 Ratings as per DOT Regulation 195.

Style 115 Reinforcing Sleeves

Where special precautions are needed, you can strengthen field joints by installing Style 115 reinforcing sleeves. The Style 115 is a full-wrap split sleeve and can be manufactured to any length required. Style 115 sleeves are factory-prepared with standard welding bevel and are machine flame-cut for uniformity and ease of installation.

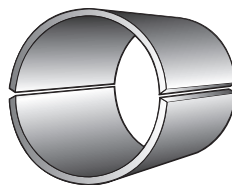

Style 115 Full-Wrap Split Sleeves are custom-fabricated to exact customer specifications. Please consult factory for details on your particular application requirements.

Style 220 Repair & Reinforcing Sleeves

For permanent reinforcement of defective coupled joints

Similar in design to the Style 110, Dresser Style 220 weld-on sleeves encompass a “pumpkin” sleeve design and are commonly used to repair corrosion pits and stress cracks. In addition, these sleeves offer a permanent repair over leaking coupled joints, flanges, valves or screw collars. Style 220 sleeves also provide a means of ensuring safety against pipe-end pullout when used to reinforce pipelines on high-pressure piping systems.

The steel construction properties of the Style 220 sleeve lends itself to field welding without preheating, using ordinary field welding procedures. All sleeves are factory prepared with standard welding bevel, machine-flame cut for uniformity and ease of welding, and come with a drilled vent hole to preclude pressure build-up between sleeve and pipe.

Built to rigid Dresser specifications, Style 220 sleeves have a minimum yield strength of 50,000 psi and an ultimate strength of 70,000 psi. Style 220 sleeves are supplied in all sizes, lengths and thicknesses as shown in chart below. Larger sizes can be supplied with weld-on handles for ease of installation.

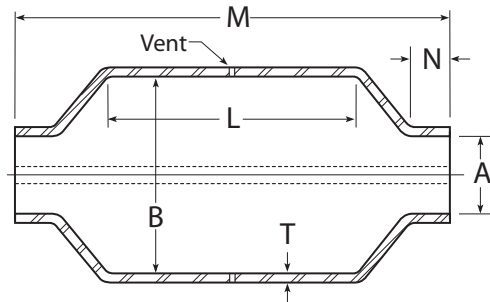

Style 220 Sleeves - Dimension specifications for sizes 2" - 26"

Nom. Size (in)	ID Diam. 'A' Pipe OD (in)	Inside Diam. 'B'	Inside Length 'L'	Outlet Dimen. 'N'	Overall Length "M"	Thickness "T"	Approx. Ship Wt. (lbs)
2*	2-3/8	8-3/8	10-1/2	1-1/4	23-1/4	5/16	45
3*	3-1/2	9-1/2	10-1/2	1-1/4	23-1/4	5/16	49
4	4-1/2	10-1/2	10	2	20-1/4	5/16	54
6	6-5/8	12-5/8	13-1/2	1-3/8	21-3/4	3/8	96
8	8-5/8	14-5/8	13-1/3	1-3/8	21-3/4	3/8	112
10	10-3/4	16-3/4	13-1/2	1-3/8	21-3/4	3/8	128
10	10-3/4	16-3/4	13-1/2	1-3/8	21-3/4	1/2	175
12	12-3/4	18-3/4	13-1/2	1-3/8	21-3/4	3/8	150
12	12-3/4	18-3/4	13-1/2	1-3/8	21-3/4	1/2	198
14	14	20	13-1/2	1-3/8	21-3/4	3/8	160
14	14	20	13-1/2	1-3/8	21-3/4	1/2	215
16	16	22	13-1/2	1-3/8	21-3/4	3/8	176
16	16	22	13-1/2	1-3/8	21-3/4	1/2	240
18	18	24	13-1/2	1-3/8	21-3/4	3/8	195
18	18	24	13-1/2	1-3/8	21-3/4	1/2	260
20	20	26	13-1/2	1-3/8	21-3/4	3/8	216
20	20	26	13-1/2	1-3/8	21-3/4	1/2	288
22	22	28	13-1/2	1-3/8	21-3/4	3/8	230
22	22	28	13-1/2	1-3/8	21-3/4	1/2	307
24	24	30	13-1/2	1-3/8	21-3/4	3/8	248
24	24	30	13-1/2	1-3/8	21-3/4	1/2	330
26	26	32	13-1/2	1-3/8	21-3/4	3/8	315
26	26	32	13-1/2	1-3/8	21-3/4	1/2	350

Material Specifications

Body High strength, low carbon steel meeting ASTM A572 GR 50 / ASTM A588

Dimensions are in inches unless otherwise noted.

NOTE: Larger diameters available upon request.

Please consult factory with your particular application requirements.

* 2" and 3" sizes have minimum yield strength of 35,000 psi.

Style 220 Repair & Reinforcing Sleeves

Style 220 Sleeves - (Maximum Operating Pressure by Location)

Pipe Size (OD) x Wall Thickness (in)	Class 1	Class 2	Class 3	Class 4
2-3/8 x 5/16 Wall	1200 G	1000 G	825 G	650 G
3-1/2 x 5/16 Wall	1000 G	875 G	725 G	575 G
4-1/2 x 5/16 Wall	1615 G	1345 G	1120 G	895 G
6-5/8 x 3/8 Wall	1610 G	1345 G	1120 G	895 G
8-5/8 x 3/8 Wall	1400 G	1170 G	975 G	780 G
10-3/4 x 3/8 Wall	1230 G	1025 G	855 G	685 G
10-3/4 x 1/2 Wall	1620 G	1350 G	1125 G	900 G
12-3/4 x 3/8 Wall	1105 G	920 G	765 G	615 G
12-3/4 x 1/2 Wall	1455 G	1215 G	1010 G	810 G
14 x 3/8 Wall	1040 G	865 G	720 G	575 G
14 x 1/2 Wall	1370 G	1140 G	950 G	760 G
16 x 3/8 Wall	945 G	790 G	655 G	525 G
16 x 1/2 Wall	1250 G	1040 G	870 G	695 G
18" x 3/8 Wall	870 G	725 G	605 G	480 G
18 x 1/2 Wall	1150 G	960 G	800 G	640 G
20 x 3/8 Wall	805 G	670 G	560 G	445 G
20 x 1/2 Wall	1065 G	885 G	740 G	590 G
22 x 3/8 Wall	750 G	625 G	520 G	415 G
22 x 1/2 Wall	990 G	825 G	690 G	550 G
24 x 3/8 Wall	700 G	585 G	485 G	390 G
24 x 1/2 Wall	925 G	770 G	645 G	515 G
26 x 3/8 Wall	655 G	545 G	455 G	365 G
26 x 1/2 Wall	870 G	725 G	605 G	480 G

Style 220 Ratings

Yield Strength 50,000 psi minimum

Temperature Ratings -20° F to +150°



All dimensions are in inches unless otherwise noted.

Style 220-S Reinforcing Sleeves

For smaller diameter repair from 3/4" to 2" ID

The Dresser Style 220-S reinforcing sleeve is a weld-over sleeve for reinforcing threaded collars, welded joints or compression couplings on small diameter pipe from 3/4" ID through 2" ID sizes. The sleeves are made to rigid Dresser specifications meeting ASTM-A513, GR1015 specs, and have a yield strength of 35,000 psi, and an ultimate strength of 48,000 psi.

Style 220-S sleeves are furnished in matched halves and all longitudinal edges are factory beveled for welding. A drilled vent hole precludes pressure build-up between sleeve and pipe during welding. Style 220-S sleeves are rated at 350 psi working pressure and meet the requirements applicable to DOT #192 codes.

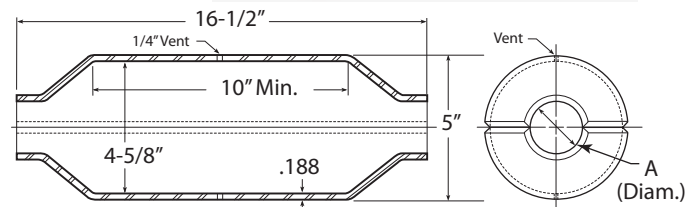

Pipe Size (OD)	Nominal Size	Diameter (A)
1.050	3/4"	1-1/8"
1.315	1"	1-3/8"
1.660	1-1/4"	1-3/4"
1.990	1-1/2"	2"
2.375	2"	2-7/16"

Dimensions are in inches unless otherwise noted.

Dresser Product Coatings

ALCLAD™ Epoxy Coating

Dresser Epoxy is a thermoset, fusion-bonded, grey coating and has outstanding physical properties and can be utilized in many piping system applications due to such features as:

- High coating dielectric strength.
- Excellent disbondment resistance in cathodically protected systems.
- Resistant to soil stress and fungi.
- Excellent adhesion in an oven-cured factory application.

All constituents of the epoxy cured film are FDA approved for exposure to fluids for human consumption. ALCLAD also provides an excellent coating for use on components of cathodic protected distribution systems. Thermoset epoxy coatings meet DOT and Federal regulation 192.461. Please consult the factory for special line content applications.

Dresser RED-D Shopcoat

Dresser Shopcoat paint is a waterborne finish, pigmented with red oxide. RED-D provides a suitable base over which primers and final coatings can be applied.

Dresser shopcoat provides a smooth, clean, non-greasy, non-sticky surface and protects all products from corrosion in normal storage situations. It is compatible with primer and enamel coatings of either hard or soft grades of plasticized or unplasticized coal tar enamels, and with asphalt coatings.

For above ground, Dresser Shopcoat will take most of the usual types of paint, including paints with color added, without bleeding through.

Applicable Warnings for Dresser Repair Products

Split Sleeves

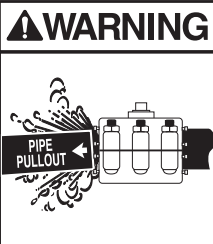

WARNING

When pipe pullout could occur, pipe joint **MUST** be anchored. Failure to anchor pipe joint could result in escaping gas that could ignite and cause property damage, serious injury or death.

Bell Joint Clamps

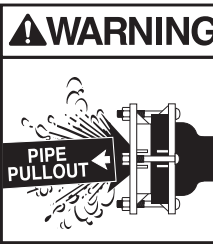

WARNING

When pipe pullout could occur, pipe joint **MUST** be anchored. Failure to anchor pipe joint could result in escaping line content that could ignite and cause property damage, serious injury or death.

NOTE: Always read the product installation instructions before installing any Dresser products.

Visit us at: www.dresserutility.com

Dresser Utility Solutions reserves the right to make changes in specifications and features shown herein, or discontinue the product described at any time without notice or obligation. Contact your Dresser sales representative for the most current information.

Dresser Pipeline Solutions

41 Fisher Avenue
Bradford, PA 16701
T: 814.362.9300
F: 814.362.9344

© 2021 Natural Gas Solutions North America, LLC - All rights reserved. The Dresser Logo and all Trademarks containing the term "Dresser" are the property of Dresser, LLC, a subsidiary of Baker Hughes

