

WATER REPAIR PRODUCTS

for Water, Wastewater and Industrial Piping Systems

Split repair sleeves, reinforcing sleeves and full-wrap repair clamps





Table of Contents

Defects/Repair Product GuidelinesPages 2-3

Repair Clamps

Style 4 and 41 Collar Leak Clamps for Steel 2" - 12"	4
Style 77 Band Clamps	5
Style 118 Handiband Clamps 1/2" - 8"	6
Style 360 Clamps 2" - 24"	7
Style 60 and 160 Bell Joint Clamps for Cast Iron 3" - 48"	8-9

Repair Sleeves

Style 80 Ready-Pack Sleeves for Cast Iron	10
Style 96 Innerpak Sleeves for High Pressure Steel - Expanded Body	11
Style 126 'Bell-Pack' Split Repair Sleeve for CIP.....	12
Style 110 Reinforcing Sleeves for Welded Joints	13
Style 220 Reinforcing Sleeves - Encasement	14
Style 220-S Reinforcing Sleeves for Small Diameter Welds & Couplings.....	15

NOTE: Never install any Dresser products before reading the installation instructions and warnings.

Dresser Pipeline Solutions offers water and industrial pipeline industry customers an array of repair products and solutions including clamps, split sleeves and reinforcing sleeves for pipeline integrity. These ruggedly built products, made of high-quality materials, are indispensable parts of a Dresser pipeline solutions portfolio that has been distinguished by industry-leading innovation and performance excellence for more than 135 years.

Our water pipeline repair fittings are used to repair the most challenging pipe repair problems, fix leaking bell joints, circumferential breaks, cracks and splits in steel, cast and ductile iron mains.

Dresser products are designed to provide simple installation and quick, economical repairs while avoiding service interruptions ensuring you get the solution that meets your pipeline repair needs. Dresser backs it up with well-versed inside customer care specialists who understand the features, capabilities, and application requirements of each Dresser repair product offering.

Dresser Utility Solutions reserves the right to make changes in specifications and features shown herein, or discontinue the product described at any time without notice or obligation. Contact your Dresser sales representative for the most current information.

Dresser Repair Product Options for STEEL Pipeline Defects

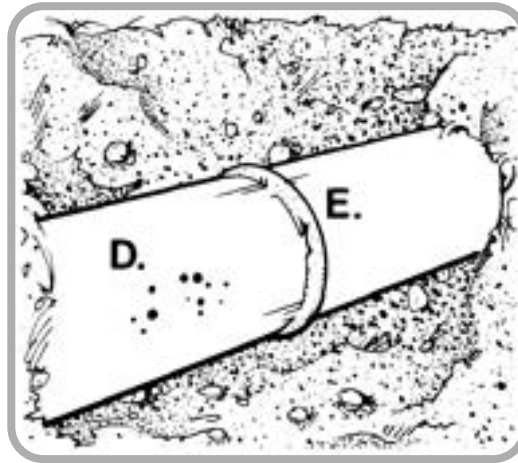
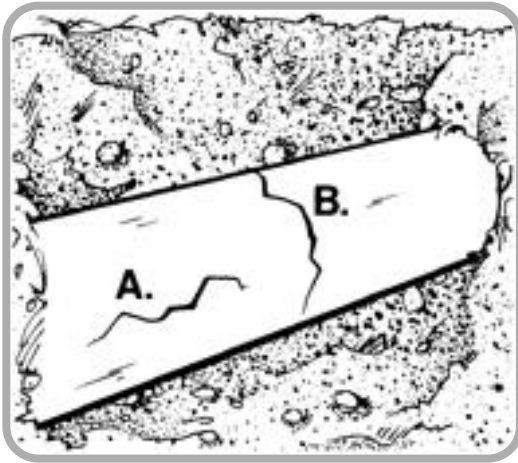

- A. Longitudinal Breaks up to 8"
- B. Circumferential Breaks
- D. Small Pinhole Leaks, Splits and Corrosion Cracks
- E. Broken Weld

Product	Size	Page
Style 77 Band Clamp	2" - 24"	5
Style 118 Handiband Clamp	1/2" - 8"	6
Style 360 Clamp	2" - 30"	7
Style 96 Split Sleeve	6" - 30"	11
Style 110 Weld Sleeve	4" - 30"	13
Style 220 Weld Sleeve	2" - 26"	14

Product	Size	Maximum Pressure
D-ONLY: Style 77	2" - 24"	150 PSI
D-ONLY: Style 118	1/2" - 4" 6" - 8"	150 PSI 100 PSI
D-ONLY: Style 360	2" - 30"	See Chart, Page 7

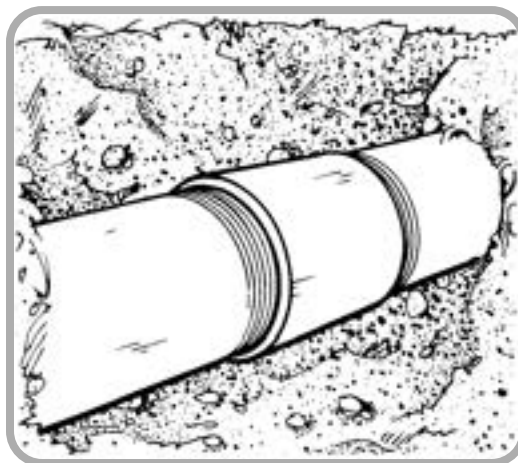

Leaking Threaded Joints and Screw Collars

Product	Size	Page
Style 4 Collar Clamp	2" - 4"	4
Style 41 Collar Clamp	6" - 12"	4

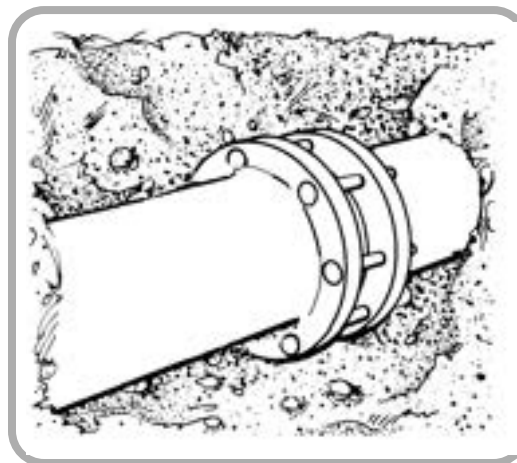

Leaking Mechanical Coupled Joints

Product	Size	Page
Style 96 Split Sleeve	6" - 30"	11
Style 220 Weld Sleeve	6" - 26"	14

Dresser Repair Product Options for CIP/DIP Pipeline Defects

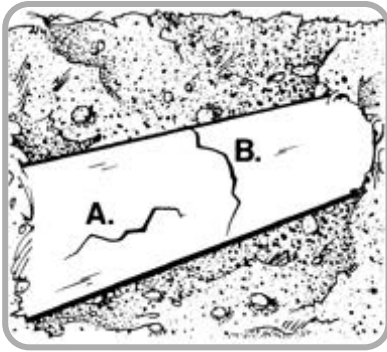

A. Longitudinal Breaks up to 8"
B. Circumferential Breaks

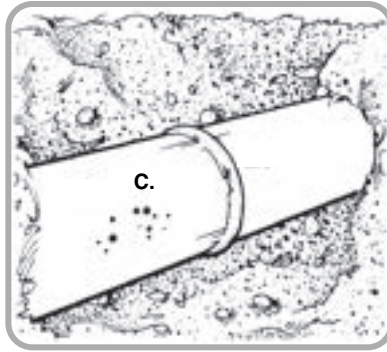

C. Small Pinhole Leaks, Splits and Corrosion Cracks

Product	Size	Page
Style 80 Split Sleeve	3" - 8"	10
Style 126 Split Sleeve	3" - 24"	12
Style 360 Clamp	2" - 30"	7

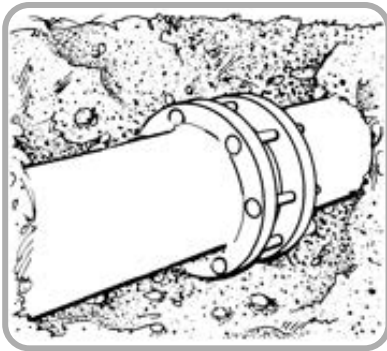

Leaking Coupled Joints or Mechanical Joints

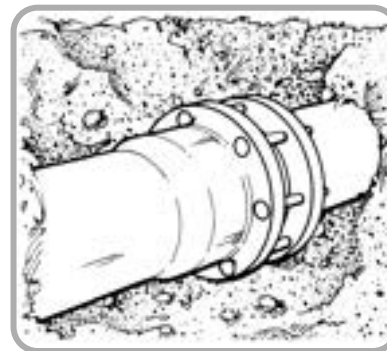

Product	Size	Page
Style 126 Split Sleeve	3" - 24"	12

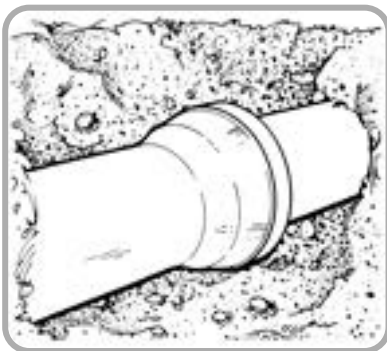

Leaking Bell or Spigot Joints, Broken or Cracked Bell Joints, Leaking or Cracked Stab-Joint

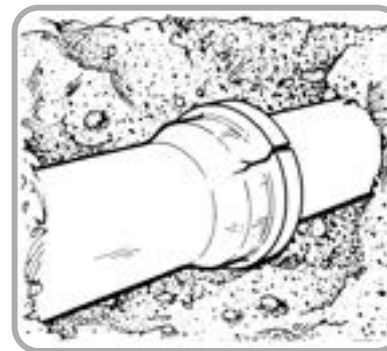

Product	Size	Page
Leaking Bell: Style 60/160 Bell Clamp	3" - 48"	10
60-S Clamp	4" - 24"	11
Cracked Bell: Style 126 Split Sleeve	3" - 24"	14

Optional Repair - New Spool Piece

Remove defective length of pipe, insert new pipe and join with two Style 38, or Style 40 couplings.

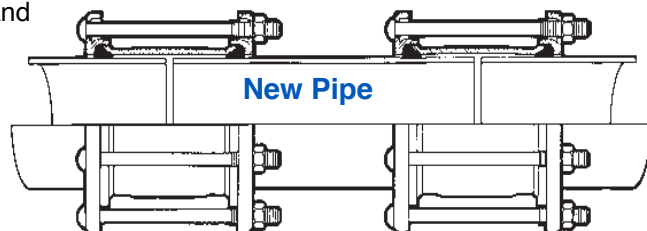

Style 4 and 41 Collar Clamps

Stops all leaks through screw collars

Dresser Style 4 and 41 clamps quickly and inexpensively stop leaks through the threads of screw collars (threaded couplings). Repairs are permanent and normally made without interrupting service or dismantling the line.

Style 4 clamps consist of two malleable split follower rings with interlocking ends on each section, two resilient split gaskets, and bolts as required for pipe sizes up to 4".

Style 41 clamps consist of the same parts, except the split follower rings are steel and are connected by steel lock links.

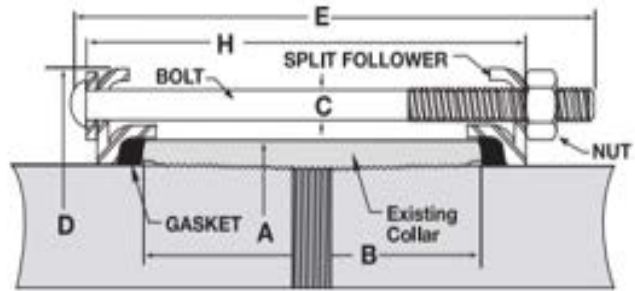

Material Specifications

Followers	Style 4 Malleable, Style 41 Steel
Bolts & Nuts	Alloy to AWWA C111/ANSI A21.11
Gasket	Grade 27 BUNA-S
Coating	RED-D, Optional Epoxy

Style 4 (Malleable) - Size Specifications for 2" – 4"

Nominal Size Steel (ID)	Outside Diameter (OD)	Collar Dimensions		Bolts Number Diameter & Length (C and E)	Clamp Dimensions		Gasket Section Dimensions (in)	Approximate Shipping Weight Ea. (lbs)
		Overall Diameter (A)	Overall Length (B)		Overall Diameter (D)	Overall Length (H)		
2	2.375	2.841	3.625	4 - 5/8 x 6-1/2	6-5/16	7	9/32 x 5/8	8
3	3.500	4.014	4.125	4 - 5/8 x 7-1/2	7-1/2	8	11/32 x 3/4	9
4	4.500	5.233	4.625	4 - 5/8 x 7-1/2	8-1/2	8	23/64 x 3/4	11

Style 41 (Steel) - Size Specifications for 6" ID – 12" ID

Nominal Size Steel (ID)	Outside Diameter (OD)	Collar Dimensions		Bolts Number Diameter & Length (C & E)	Clamp Dimensions		Gasket Section Dimensions (in)	Approximate Shipping Weight Ea. (lbs)
		Overall Diameter (A)	Overall Length (B)		Overall Diameter (D)	Overall Length (H)		
6	6.625	7.482	5.125	6 - 5/8 x 8-1/2	10-3/4	9-1/2	7/16 x 3/4	23
8	8.625	9.596	6.125	6 - 5/8 x 9-1/2	12-7/8	10-1/2	1/2 x 3/4	28
10	10.750	11.958	6.625	8 - 5/8 x 10	15-3/8	11	5/8 x 23/32	44
12	12.750	13.958	6.625	8 - 5/8 x 10,,5	17-3/8	11	5/8 x 23/32	50

Dimensions are in inches unless otherwise noted.

Style 77 Band Clamps

For repair of pinhole leaks

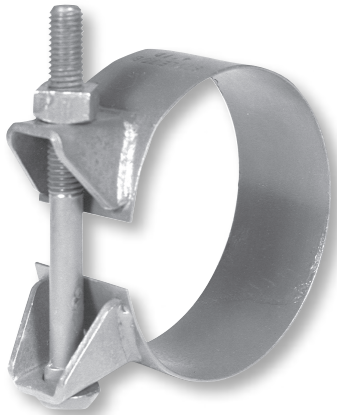

PRESSURE RATING: 150 PSI All Sizes

Dresser Style 77 band clamps are specifically designed to provide a low cost repair for small pinholes, leaks, corroded areas and pits in straight runs of steel piping. They are suitable for virtually all working temperatures and line contents. 150 MAOP in all sizes.

Each clamp consists of a flexible, one-piece carbon steel circular band that is sprung apart to fit over the pipe, and a high-strength carbon steel bolt and nut of sufficient diameter to provide both a safety factor and protection against corrosion. The 77 clamp is available in standard steel pipe sizes from 2" through 24" with 2" or 3" wide bands. NOTE: Cone gaskets are ordered separately and must be specified when ordering the Style 77 repair clamp with three different size cone gaskets available as noted below.

Material Specifications	
Band/Lugs	AISI C1008/1010 Carbon Steel
Bolt & Nut	AWWA C111/A21.11
Gasket (77)	100% Pure Gum Rubber; 1/4" Minimum Thickness, 40 Durometer
Coating	Fusion-Bonded Grey Epoxy



Style 77 Cone Gasket		Order Separately
Gasket Number	Gasket Size (in)	Dresser Part Number
216	1-5/8"	30770001001
217	2"	30770002001
218	2-1/2"	30770004001

Style 77 Band Clamps - Size Specifications 2" – 24"

Pipe (Steel) Nominal Size (ID)	Outside Diameter (OD)	Band Thickness & Width	Bolt Diameter & Length	Approximate Ship Weight Ea. (lbs.)
2	2.375	1/16 x 2	1/2 x 4	0.84
3	3.500	1/16 x 2	1/2 x 4	0.96
4	4.500	1/16 x 2	1/2 x 5-1/2	1.3
5	5.563	1/16 x 2	1/2 x 5-1/2	1.4
6	6.625	3/32 x 3	5/8 x 6	2.8
6-5/8 CAS	7.000	3/32 x 3	5/8 x 6	2.9
8	8.625	3/32 x 3	5/8 x 6	3.4
10	10.750	3/32 x 3	5/8 x 7	4.0
11-5/8 CAS	12.000	3/32 x 3	5/8 x 7	4.3
12	12.750	3/32 x 3	5/8 x 7	4.5
14	14.000	1/8 x 3	5/8 x 8-1/4	6.2
16	16.000	1/8 x 3	5/8 x 8-1/4	6.9
18	18.000	1/8 x 3	5/8 x 8-1/4	7.5
20	20.000	1/8 x 3	5/8 x 8-1/4	8.2
24	24.000	1/8 x 3	5/8 x 8-1/4	9.6

Dimensions are in inches unless otherwise noted.

Style 118 Handiband Clamps

For quick, permanent repair of small holes in steel pipe

The Dresser Style 118 Handiband Clamp is a field-proven, low cost band-type repair clamp for quick repair of small leaks and holes in steel gas piping. Installation is fast and easy. Simply wrap the clamp around the pipe with gasket centered over the leaking area, drop the boltheads through the slotted lugs and tighten the nuts. Compression of the large size gasket seals the leak completely and permanently.

Individual components of the Style 118 clamp are carefully engineered and constructed with lugs of ductile iron and plated bolts for long life and durability. The Style 118 clamp is made of stainless steel for corrosion resistance and comes fully assembled so there are no loose parts to misplace. Available 2" thru 8" with optional band lengths of 3, 6 and 12". The gridded rubber compounded gasket offers end to end sealing and will retain their resilience for the life of the pipeline.

NOTE: The Style 118 clamp does not provide a full 360-degree seal on the pipe. For full circle seal and repair applications, see the Style 360 repair clamp on page 7.



Material Specifications

Band	Stainless Steel 18-8, Type 304
Lugs	Ductile Iron ASTM 536
Bolts & Nuts	ASTM A307
Gasket	Gridded to Dresser specs

Pressure Ratings

1/2" thru 4"	150 PSI
5" thru 8"	100 PSI

Torque Recommendations

Clamp Size	Max Torque
1/2" thru 1-1/2"	25 ft. lbs.
2" thru 8"	35 ft. lbs.

Style 118 Handiband Repair Clamp - Size Specifications for 1/2" thru 8"; Band Lengths Options of 3", 6" and 12"

Nominal Size (ID)	Outside Diameter (OD)	Overall Length (in)	Quantity per Package	Weight Ea. (lbs)
1/2	.840	3	20	.50
1/2	.840	6	10	1.00
3/4	1.050	3	16	.60
3/4	1.050	6	8	1.10
1	1.315	3	16	.60
1	1.315	6	8	1.20
1-1/4	1.660	3	12	.90
1-1/4	1.660	6	6	1.70
1-1/2	1.900	3	12	.90
1-1/2	1.900	6	6	1.80
2	2.375	3	8	1.11
2	2.375	6	4	2.30
2	2.375	12	2	4.50
2-1/2	2.875	3	8	1.20
2-1/2	2.875	6	2	2.30

Nominal Size (ID)	Outside Diameter (OD)	Overall Length (in)	Quantity per Package	Weight Ea. (lbs)
3	3.500	3	6	1.20
3	3.500	6	4	2.40
3	3.500	12	2	4.80
3-1/2	4.000	3	6	1.50
3-1/2	4.000	6	4	3.00
4	4.500	3	6	1.50
4	4.500	6	4	3.10
4	4.500	12	2	6.30
5	5.563	3	6	1.60
5	5.563	6	4	3.21
6	6.625	3	6	1.80
6	6.625	6	4	3.60
6	6.625	12	1	7.20
8	8.625	3	6	2.00
8	8.625	6	4	4.00
8	8.625	12	1	7.00

Dimensions are in inches unless otherwise noted.

NOTE: All orders for unpackaged sizes and for broken carton quantities will be randomly packaged

Style 360 Repair Clamps

For fast repair of leaks in cast/ductile and steel mains

The Dresser Style 360 repair clamp offers simplicity and ease of installation. Just wrap the clamp around the pipe, drop the bolts in place and tighten. It's that simple! Moreover, special one-inch long nuts allow the use of a standard deep socket wrench for complete tightening. In the popular 7.5 inch clamp width, there is also a third bolt, so the middle bolt and nut can be used to pre-tighten the clamp. Additionally, the smaller clamps feature a flexible band, which means less holding force is required while tightening.

With the Style 360 clamp, you can repair holes, breaks and splits in the pipeline...You can even use it where pipe ends are separated, or where ends are deflected up to 4 degrees or 1/8 inch. Clamp features include a tapered gasket with a gridded design, and the spanner is molded flush with the gasket to prevent "hang up." The Style 360 clamp has a stainless band, lugs of rugged ductile iron and bolts of corrosion-resistant Dresserloy.



Style 360 Clamp Features:

- One-inch long nuts allow tightening with standard deep socket wrench.
- Drop-in bolts - No need to remove bolts in the ditch. No loose parts to misplace.
- Multi-Band clamp - Features a multi-band design in the 14" through 24" sizes. Clamp is packaged and shipped "in the flat," meaning the bands are not formed to the radius of the pipe. Reduces storage space and installation time, and has twice the adjustment range of the single-band clamp.

Material Specifications	
Band	AISI Type 304 Stainless Steel
Lugs	Ductile Iron
Nuts	AWWA C111/A21.11
Bolts	AWWA C111/A21.11
Spanner	AISI Type 304 Stainless Steel
Gasket	Gridded Surface to Dresser Specs, 55 Durometer

Style 360 Clamp – Specifications for Sizes 2" - 30"

Nom. Size (in)	Range of Fit (OD)	Clamp Widths (in)	Max. PSI
2	2.35 - 2.63	7-1/2, 12-1/2	250
	2.70 - 3.00	0.024" Thick Band	
3	2.97 - 3.25	7-1/2 or 12-1/2	250
	3.46 - 3.70	7-1/2 or 12-1/2, 20	220
	3.73 - 4.00	0.024" Thick Band	
4	4.45 - 4.86	7-1/2, 12-1/2	170
	4.74 - 5.14	15, 20, 30	
	4.95 - 5.35	0.024" Thick Band	
4-5	5.22 - 5.62	7-1/2, 12-1/2	200
		15, 20, 30 0.036" Thick Band	
6	5.95 - 6.35	7-1/2, 12-1/2, 20, 30 0.036" Thick Band	200
	6.56 - 6.96		
	6.84 - 7.24		
	7.05 - 7.45		
	7.45 - 7.85		
8	7.95 - 8.35	7-1/2, 12-1/2, 15, 20, 30 0.036" Thick Band	160
	8.54 - 8.94		
	8.99 - 9.39		
	9.27 - 9.67		
	9.68 - 10.08		
	9.70 - 10.10		
10	10.64 - 11.05	7-1/2, 12-1/2, 15, 20, 30 0.036" Thick Band	90

Nom. Size (in)	Range of Fit (OD)	Clamp Widths (in)	Max. PSI
10	11.04 - 11.44	7-1/2, 12-1/2, 15, 20, 30 0.036" Thick Band	90
	11.34 - 11.74		
	11.75 - 12.15		
	12.00 - 12.40		
12	12.62 - 13.02	7-1/2, 12-1/2, 15, 20, 30 0.036" Thick Band	90
	13.10 - 13.50		
	13.40 - 13.80		
	13.70 - 14.10		
2-Band Sizes	14.00 - 14.40	20, 30 0.048" Thick Band	130
	14.38-15.13		
	15.07 - 15.82		
	15.92 - 16.67		
	16.56 - 17.31		
	17.15 - 17.90		
	17.82 - 18.57		
	18.46 - 19.21		
	19.23 -19.98		
	19.90 - 20.65		
	20.70 - 21.45		
21.52 - 22.27			
22.12 - 22.87			
22.90 - 23.65			
3-Band Sizes	23.28 - 24.38	20, 30 0.048" Thick Band	45
	29.62 - 30.72		

Dimensions are in inches unless otherwise noted.

NOTE: On any given installation, the pressure capability of the clamps is influenced by the type and extent of the damage, service conditions, environmental conditions and installation workmanship.

Style 60 and 160 Bell Joint Clamps

For repair of cast iron bell and spigot joints

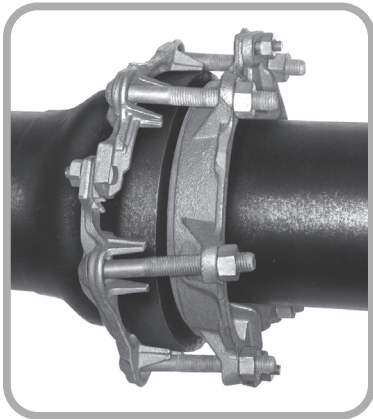

Dresser bell joint clamps permanently stop or prevent leaks through the jointing materials of cast iron bell and spigot joints. Completely adjustable to provide a close fit on both the pipe bell and spigot, one standard clamp fits virtually all makes of pipe within a nominal size.

Style 60 and 160 clamps can be quickly installed with no interruption of service. A large, special rubber compound gasket shuts off the leak when compressed as the spigot ring is drawn up and, in turn, by bolts connected to the bell ring (anchored on the bell).

Style 60 Clamp

The spigot ring of the Style 60 clamp offers a wide range of adjustment made possible by the use of clips having fillers with the same cross section of the spigot ring. Serrated ends on the bell ring sections offer a simple and effective means of adjustment, providing a positive fit for varying outside bell diameters.

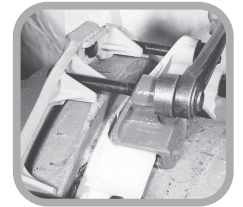

Style 160 Clamp

The Style 160 clamp features a hinged, wraparound spigot ring design. There are no clips and the spigot sections have serrated ends that bolt together.

Gasket Tong

Dresser gasket tongs help simplify the installation of bell joint clamps. The tongs hold the gasket in place while the clamp is being bolted up, assuring full, uniform gasket compression. Consult factory for product details.



Only products bearing the NSF Mark on the product, product packaging, and/or documentation shipped with the product are Certified.

Material Specifications

Rings	Cast Ductile Iron to ASTM A536
Bolts and Nuts	AWWA C111/A21.11
Spigot Ring Bolts	ASTM A-307
Clips	Ductile or Malleable Iron
Gasket	Grade 27 BUNA-S
Coating	Grey Epoxy

Style 60 and 160 - Size Specifications for 3" – 16"

Nominal Size (CIP)	Gasket Thickness x Length	Bolts Number Diam. x Length	Weight Shipping Ea. (lbs)
3	1-1/8 x 1	4 – 5/8 x 5	13
4 ¹	1-1/8 x 1	4 – 5/8 x 5	15
6 ¹	1-1/8 x 1	6 – 5/8 x 5-1/2	21
8 ¹	1-1/8 x 1	6 – 5/8 x 5-1/2	24
10	1-1/8 x 1	8 – 5/8 x 5-1/2	35
12 ¹	1-1/8 x 1	9 – 5/8 x 5-1/2	38
14	1-1/8 x 1	9 – 5/8 x 6	46
16 ¹	1-1/8 x 1	9 – 5/8 x 6	50

Style 60 and 160 - Size Specifications for 18" – 48"

Nominal Size (CIP)	Gasket Thickness x Length	Bolts Number Diam. x Length	Weight Shipping Ea. (lbs)
18	1-1/8 x 1	12 – 5/8 x 6-1/2	73
20	1-1/8 x 1	12 – 5/8 x 6-1/2	74
24	1-1/8 x 1	12 – 5/8 x 7	86
30	1-1/8 x 1	16 – 5/8 x 7	113
36	1-1/8 x 1	20 – 5/8 x 7	148
42	1-1/8 x 1	24 – 5/8 x 7-1/2	199
48	1-1/8 x 1	24 – 5/8 x 7-1/2	227

Dimensions are in inches unless otherwise noted.

¹NOTE: Style 160 Clamps may be furnished in these sizes.

Style 60-S Bell Joint Clamps

For repair of stab-type bell joints

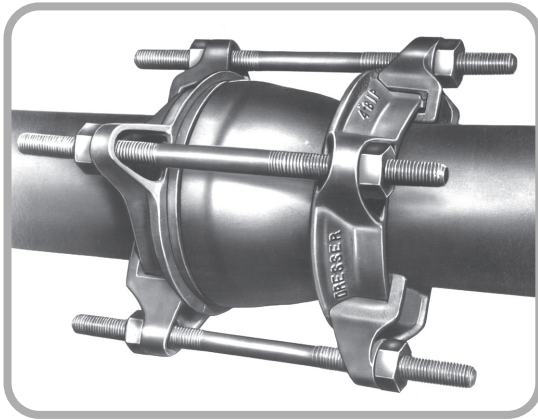

Dresser Style 60-S bell joint clamps are similar to the standard Style 60 clamp, but consist of two spigot rings rather than one spigot and one bell ring. This difference in design is necessary because most stab-type joints, including cast-iron pipe, have a long, tapered bell that has no shoulder for anchoring a bell ring.

Long studs are provided for adjustability to provide a close fit on both pipe bell and spigot ends. A large, special rubber compound gasket shuts off the leak when compressed, as the spigot rings are drawn up and the studs are tightened against the bell. Style 60-S clamps can be quickly installed with no interruption of service.



Only products bearing the NSF Mark on the product, product packaging, and/or documentation shipped with the product are Certified.

Material Specifications

Spigot Rings	Ductile or Malleable Iron
Studs & Nuts	AWWA C111/A21.11
Gasket	Grade 27 Buna-S
Coating	Fusion-Bonded Epoxy

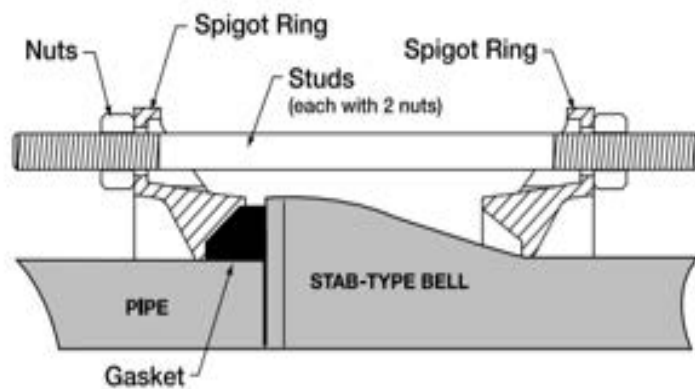

Style 60-S Clamp – Size Specification for 4" – 36"

Nominal Size (CIP)	Spigot Ring Part Number (2 per clamp)	Studs Number Diameter x Length	Approximate Ship Weight Ea. (lbs.)
4	160AO480	4 - 5/8 x 13	18
6	160AO690	6 - 5/8 x 13	27
8	160AO905	6 - 5/8 x 13	33
10	60B1110	8 - 5/8 x 13	43
12	160A1320	8 - 5/8 x 13	48
14	60A1530	9 - 5/8 x 13	71
16	60B1740	9 - 5/8 x 16	74
18	60A1950	12 - 5/8 x 16	91
20	60A2160	12 - 5/8 x 16	100
24	60D2580	12 - 5/8 x 16	115
30	60A3174	16 - 5/8 x 16	171
36	60B3830	20 - 5/8 x 16	247

Dimensions are in inches unless otherwise noted.

NOTE: Style 60-S Clamps can be used on caulked cast iron pipe joints for Class A, B, C and D C900 pipe sizes through 24"; Same pipe for Class A, B, and C in sizes 30" and 36".

Style 80 Split 'Ready-Pack' Sleeves

For repairs on cast iron pipe



Dresser Style 80 split 'ready-pack' sleeves are used to enclose and permanently repair breaks, splits and holes in cast iron pipe. With vent sizes 1" thru 3", Style 80 sleeves can also be used as an efficient, low-cost tapping sleeve for branch service connections.

Style 80 sleeve bodies are cast from close-grained gray iron. Steel follower rings on each end are completely enclosed in the sleeve body. Carbon steel set screws are drawn up against the follower ring to compress the gasket, creating total circumferential sealing on the pipe. Side bolts, which are fully enclosed within the sleeve body to prevent corrosion, are tightened to compress side gaskets and provide a complete leakproof seal.

Style 80 sleeves are recommended for all customary pressures where pipe wall thickness is in conformity with specifications for standard cast iron pipe.

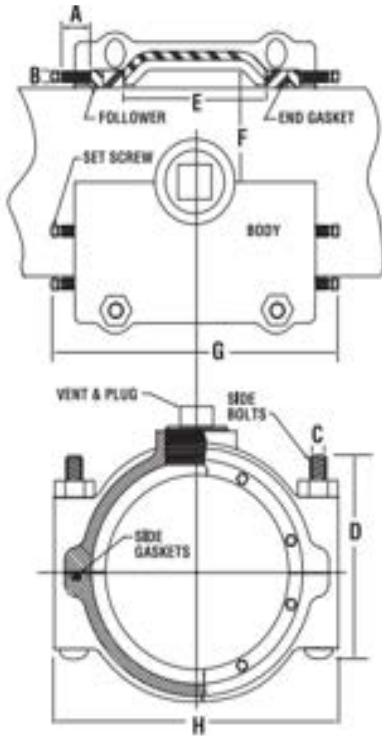

Material Specifications	
Body	Cast Iron, RED-D Shopcoat
Vent Plug	Forged Steel to ASTM A105 or Cast to ASTM A126-42 Class A
Follower Rings	Cold-formed Carbon Steel
Bolts & Nuts	Alloy to AWWA C111/ANSI A21.11
Gaskets	Grade 29 Spec 328
Set Screws	Heat-treated Carbon Steel, Cadmium Plated

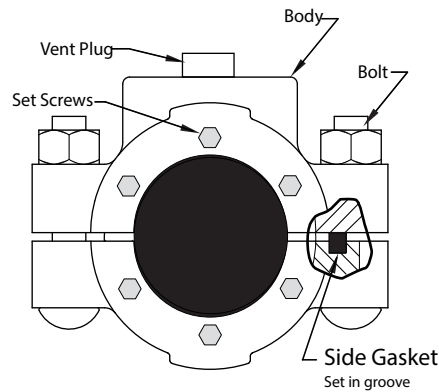

Style 80 Split Sleeves - Size Specifications for Cast Iron Pipe (All Sizes 150 MAOP)

Nom. Pipe Size (CIP)	Range of Fit (OD)	End Screws Number Diam. x Length A & B	Side Bolts Number Dia. x Length C & D	End Gasket Section Dimen. (in)	Side Gasket Section Dimen. (in)	Inside Dimension ¹ Diam. (E) Length (F)		Overall Dimension Diam. (H) Length (G)		Vent Diam. (in)	Weight Ea. (lbs)
						(E)	(F)	(H)	(G)		
3	3.75-4.00	12- 3/8X1	4-5/8 x 5-1/2	5/8 x 3/4	5/16 x 1/2	4	5-5/32	9-3/8	7-15/16	1-1/4 - 2	40
4	4.74-4.99	12- 3/8X1	4-5/8 x 5-1/2	5/8 x 3/4	5/16 x 1/2	4	6-5/32	9-3/8	8-15/16	1 - 2	45
			2-5/8 x 5-1/2						10-7/8	1-1/4 - 3	55
6 ²	6.84-7.09	16- 3/8X1	4-5/8 x 6-1/2 2-5/8 x 5-1/2	5/8 x 3/4	5/16 x 1/2	4	8-1/4	9-5/16	11-7/8	1-1/4 - 3	70
8 ²	8.99-9.24	20- 3/8X1	4 5/8 x 7-1/2 2 5/8 x 5-1/2	5/8 x 3/16	5/16 x 1/2	7	10-13/32	12-1/2	11-7/8	1-1/4 - 4	100

Dimensions are in inches unless otherwise noted.

¹ Inside Dimension "E" as indicated in cross section drawing, is distance between inside of end gaskets. This length is equal to or greater than found between calking spaces in foundry "splits" as shown in AGA Standards Specifications for Service Sleeves.

² Long Pattern Design with vents up to 4". Style 80 long body sleeves have six side bolts.

Style 96 Split Repair Sleeves

Expanded body split sleeve for repairs on steel pipe

Dresser Style 96 split repair sleeves offer an expanded body for repairing coupled or mechanical joints on high-pressure steel transmission piping systems up to 500 PSI .

Style 96 sleeves are fabricated from high-quality carbon steel and come completely factory-assembled for quick installation. All sleeves are vented for installation under pressure without service interruptions.

- Designed to completely enclose and permanently repair leaking coupled joints or encase defective screw collars or butt-welded joints.
- End cap screws with encased follower ring design provides additional circumferential sealing around the pipe.

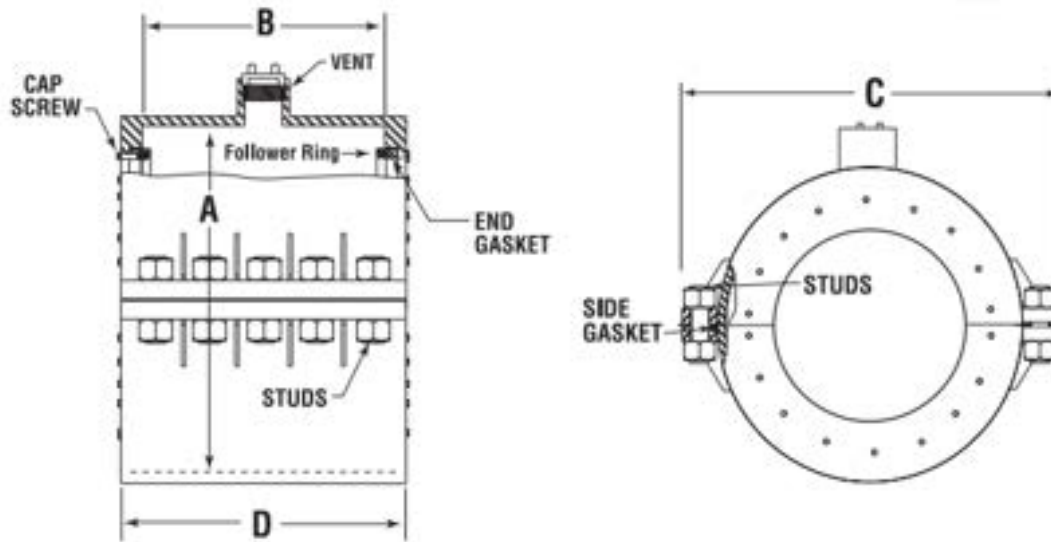

Style 96 Split Sleeves - Dimension Specifications for Steel Pipe Sizes 6"- 30". Rated up to 500 PSI

Steel Pipe Nom. Size (in)	Outside Diam. (OD)	Inside Dim.		Overall Dim.		Vent Diam. (in)
		(A)	(B)	(C)	(D)	
6	6.625	12-5/8	14	17-7/8	18-3/8	2
8	8.625	14-5/8	14	19-7/8	18-3/8	2
10	10.75	16-3/4	14-1/4	22	18-7/8	3
12	12.75	18-3/4	14-1/4	24-1/4	20-3/4	3
14	14.00	20	14-1/4	25-1/2	20-3/4	3
16	16.00	20	14-1/4	27-1/2	20-3/4	4
18	18.00	20	14-1/4	29-1/2	20-3/4	4
20	20.00	26	14-1/4	32-1/4	20-3/4	4
22	22.00	28	14-1/4	34-1/4	20-3/4	4
24	24.00	30	16	36-1/8	22-1/2	4
26	26.00	32	17-1/4	38-1/2	21-3/4	4
28	28.00	34	17-1/4	40-1/2	21-3/4	4
30	30.00	36	17-1/4	42-5/8	21-3/4	4

Material Specifications	
Body Halves	Weldable Steel suitable for the particular application to ASTM A36 or equivalent
Follower Ring	Carbon Steel AISI C1015
Cap Screws	Heat-treated Carbon Steel C1038
Bolts	Meet ASTM A193 Grade B7 and the strength requirements of the application
Gaskets	Grade 29 - Spec 328
Coating	Dresser RED-D Shopcoat (Standard) Fusion-bonded Epoxy Optional
Temperature	-20° F to 150° F

Dimensions are in inches unless otherwise noted.

Style 126 Bell-Pack Repair Sleeves

For repair of broken cast iron bell and spigot joints

Pipeline maintenance personnel avoid pipeline shutdowns and expensive, temporary makeshift repairs by installing the Dresser Style 126 Bell-Pack repair sleeve for a fast, economical and permanent repair. A sleeve of lighter weight and compact design, the Style 126 provides maximum inside dimension clearance for repairing split cast iron bells and leaking mechanical joints.

Built to rigid Dresser specifications, Style 126 repair sleeves provide the time-proven features of the Dresser rubber-packed gasket sealing design. Side bolts enclosed within the sleeve body, are then tightened to compress side gaskets providing a complete, permanent leakproof seal. Carbon steel set screws are tightened against the enclosed follower ring to compress the end gaskets, creating total circumferential sealing on the pipe.

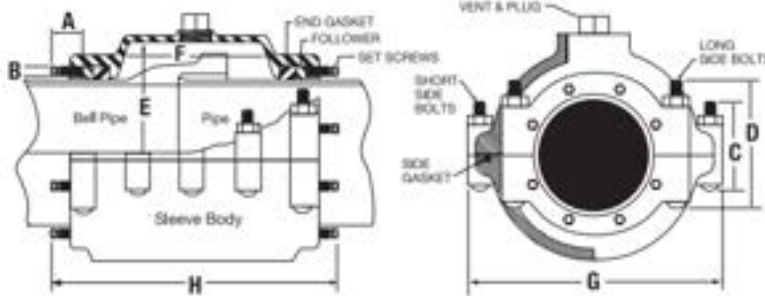
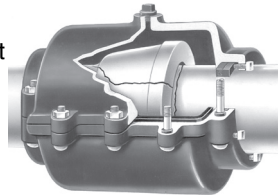

Material Specifications	
Body	Cast or malleable iron through 8" CIP. Larger sizes are special designs fabricated steel plate and bar.
Vent Plug	Forged Steel to ASTM A105 or Cast to ASTM A126-42 Class A
Followers	Cold-formed Carbon Steel
Bolts	Alloy to AWWA C111/ANSI A21.11
Gaskets	Grade 29 - Spec 328
Set Screws	Carbon Steel, Cadmium Plated
Coating	Dresser RED-D Shopcoat standard; Fusion-bonded Epoxy optional

Style 126 Repair Sleeve - Specifications for Cast Iron Sizes 4"- 24" (100 PSI All Sizes)

Nom. Size (CIP)	Outside Diam. (OD)	End Screws ¹ Dia. x Length (A) & (B)	Short Side Bolts Number ² Dia. x Length (C)	Long Side Bolts Number Dia. x Length (D)	Inside Dimension Diameter Length		Overall Dimension Diameter Length		Vent ³ Diam. (in)	Weight Approx. Ea. (lbs)
					(E)	(F)	(G)	(H)		
4	4.800	12-3/8 x 1	6-5/8 x 4	4-5/8 x 6	10	12	14-1/2	19-1/16	1	136
4	5.000	12-3/8 x 1	6-5/8 x 4	4-5/8 x 6	10	12	14-1/2	19-1/16	1	136
6	6.900	16-3/8 x 1	6-5/8 x 5	4-5/8 x 7	12-1/2	12	17-1/8	19-1/16	1	185
6	7.100	16-3/8 x 1	6-5/8 x 7	4-5/8 x 7	12-1/2	12	17-1/8	19-1/16	1	185
8	9.050	20-3/8 x 1-1/4	6-5/8 x 5	4-5/8 x 7-1/2	15-1/2	12-3/8	20-1/4	19-3/16	1	265
8	9.300	20-3/8 x 1-1/4	6-5/8 x 5	4-5/8 x 7-1/2	15-1/2	12-3/8	20-1/4	19-3/16	1	265
10	11.100	24-7/16 x 2-1/4	12-3/4 x 4	—	16-5/8	13-1/2	22-3/8	18-5/8	1	300
10	11.400	24-7/16 x 2-1/4	12-3/4 x 4	—	16-5/8	13-1/2	22-3/8	18-5/8	1	300
12	13.200	28-7/16 x 2-1/4	12-7/8 x 4	—	18-3/4	13-1/2	24-1/2	18-5/8	1	335
12	13.500	28-7/16 x 2-1/4	12-7/8 x 4	—	18-3/4	13-1/2	24-1/2	18-5/8	1	335
16	17.400	32-7/16 x 2-1/4	14-7/8 x 4	—	24	16	30	21-1/8	2	554
16	17.800	32-7/16 x 2-1/4	14-7/8 x 4	—	24	16	30	21-1/8	2	554
20	21.600	40-7/16 x 2-1/4	14-1 x 4	—	30	17	36	22-1/8	3	770
20	22.060	40-7/16 x 2-1/4	14-1 x 4	—	30	17	36	22-1/8	3	770
24	25.800	48-7/16 x 2-1/4	14-1 x 4	—	33-7/8	18	39-7/8	23-1/8	3	853
24	26.320	48-7/16 x 2-1/4	14-1 x 4	—	33-7/8	18	39-7/8	23-1/8	3	853

Dimensions are in inches unless otherwise noted.

¹ End Screws are high-grade steel, and have square heads, 3/8" across flats.

² Side Bolts are high-grade steel with trackheads and rolled threads through 8" size. Larger sizes are supplied with galvanized machine bolts.

³ Vent supplied with ASME B1.20.1 pipe threads.

⁴ Fabricated Style 126 sleeves have end seal design similar to Style 96.

Style 110 Weld-On Reinforcing Sleeves

Split repair and integrity reinforcement sleeve for repair of welded joints

Pipeline engineers assure the safety of field joints by installing Dresser Style 110 reinforcing sleeves on welded joints where special precautions are required. Style 110 sleeves can be used on defective 'trouble spots' on piping systems, at highway, river and railroad crossings, at overbends, at tie-ins, in marshy ground, near buildings, and other places where special precautions are necessary.

Fabricated in high-strength low carbon steel meeting ASTM A572 GR 50 specs, the Style 110 sleeve lends itself to field welding without preheating, using ordinary field welding procedures. All sleeves are factory prepared with standard welding bevel, machine flame cut for uniformity and ease of welding, and come with a drilled vent hole to preclude pressure buildup between sleeve and pipe.

Built to rigid Dresser specifications, Style 110 sleeves have a minimum yield strength of 50,000 PSI and an ultimate strength of 70,000 PSI. Style 110 sleeves are supplied in all standard sizes, lengths and thicknesses (see charts below). Custom-built larger sizes and lengths available upon request.

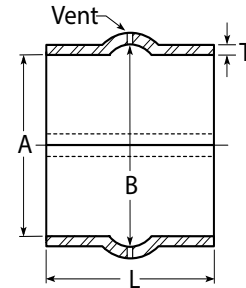

Style 110 Sleeves - Dimension specifications for nominal sizes 4" thru 30" and lengths 6" - 24" (with vent)

Nom. Size (in)	ID Diam. 'A' Pipe OD (in)	Diam. 'B' (in)	Length 'L' (in)	Thickness 'T' (in)	Approx. Ship Wt. (lbs)
4	4-1/2	5-3/8	4	5/16	5.5
6	6-5/8	7-1/2	6	3/8	16
8	8-5/8	9-1/2	6	3/8	19
8	5/8	9-1/2	8	3/8	27
8	8-5/8	9-1/2	6	1/2	26
8	8-5/8	9-1/2	8	1/2	35
10	10-3/4	11-5/8	6	3/8	23
10	10-3/4	11-5/8	10	3/8	38
10	10-3/4	11-5/8	6	1/2	31
10	10-3/4	11-5/8	10	1/2	50
12	12-3/4	14-1/4	6	3/8	27
			9	3/8	40
			12	3/8	45
			6	1/2	36
			9	1/2	55
			12	1/2	74
14	14	15-1/2	6	3/8	30
			9	3/8	45
			14	3/8	70
			6	1/2	40
			9	1/2	60
			14	1/2	94
16	16	17-1/2	6	3/8	35
			9	3/8	52
			12	3/8	68
			16	3/8	90
			6	1/2	46
			9	1/2	70
			12	1/2	90
			16	1/2	120
18	18	19-1/2	6	3/8	39
			9	3/8	58
			12	3/8	77
			18	3/8	114
			6	1/2	51
			9	1/2	78
			12	1/2	101
			18	1/2	152
20	20	21-1/2	6	3/8	43
			9	3/8	64
			12	3/8	84
			20	3/8	139

Nom. Size (in)	ID Diam. 'A' Pipe OD (in)	Diam. 'B' (in)	Length 'L' (in)	Thickness 'T' (in)	Approx. Ship Wt. (lbs)
20	20	21-1/2	6	1/2	58
			9	1/2	86
			12	1/2	112
			20	1/2	186
			21	1/2	195
22	22	23-1/3	6	3/8	47
			9	3/8	70
			12	3/8	92
			22	3/8	166
			6	1/2	64
			9	1/2	94
			12	1/2	123
			22	1/2	230
24	24	25-1/2	6	3/8	51
			9	3/8	76
			12	3/8	100
			16	3/8	133
			24	3/8	198
			6	1/2	69
			9	1/2	101
			12	1/2	133
			16	1/2	177
			24	1/2	265
26	26	27-1/2	6	3/8	56
			9	3/8	82
			12	3/8	109
			16	3/8	143
			26	3/8	232
			6	1/2	75
			9	1/2	110
			12	1/2	144
			16	1/2	190
			26	1/2	310
30	30	31-1/2	6	3/8	64
			9	3/8	95
			12	3/8	125
			16	3/8	164
			30	3/8	310
			6	1/2	85
			9	1/2	127
			12	1/2	166
			16	1/2	220
			30	1/2	410

Style 220 Repair & Reinforcing Sleeves

For permanent reinforcement of defective coupled joints on steel pipelines

Similar in design to the Style 110, Dresser Style 220 weld-on sleeves encompass a “pumpkin” sleeve design and are commonly used to repair corrosion pits and stress cracks. In addition, these sleeves offer a permanent repair over leaking coupled joints, flanges, valves or screw collars. Style 220 sleeves also provide a means of ensuring safety against pipe-end pullout when used to reinforce pipelines on high-pressure piping systems.

The steel construction properties of the Style 220 sleeve lends itself to field welding without preheating, using ordinary field welding procedures. All sleeves are factory prepared with standard welding bevel, machine-flame cut for uniformity and ease of welding, and come with a drilled vent hole to preclude pressure buildup between sleeve and pipe.

Built to rigid Dresser specifications, Style 220 sleeves have a minimum yield strength of 50,000 PSI and an ultimate strength of 70,000 PSI. Style 220 sleeves are supplied in all sizes, lengths and thicknesses as shown in chart below. Larger sizes can be supplied with weld-on handles for ease of installation.

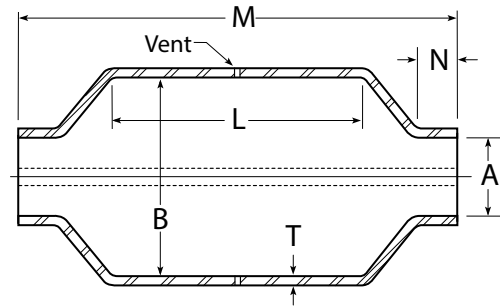

Style 220 Sleeves - Dimension specifications for sizes 2"- 26"

Nom. Size (in)	ID Diam. 'A' Pipe OD (in)	Inside Diam. 'B'	Inside Length 'L'	Outlet Dimen. 'N'	Overall Length "M"	Thickness "T"	Approx. Ship Wt. (lbs)
2*	2-3/8	8-3/8	10-1/2	1-1/4	23-1/4	5/16	45
3*	3-1/2	9-1/2	10-1/2	1-1/4	23-1/4	5/16	49
4	4-1/2	10-1/2	10	2	20-1/4	5/16	54
6	6-5/8	12-5/8	13-1/2	1-3/8	21-3/4	3/8	96
8	8-5/8	14-5/8	13-1/3	1-3/8	21-3/4	3/8	112
10	10-3/4	16-3/4	13-1/2	1-3/8	21-3/4	3/8	128
10	10-3/4	16-3/4	13-1/2	1-3/8	21-3/4	1/2	175
12	12-3/4	18-3/4	13-1/2	1-3/8	21-3/4	3/8	150
12	12-3/4	18-3/4	13-1/2	1-3/8	21-3/4	1/2	198
14	14	20	13-1/2	1-3/8	21-3/4	3/8	160
14	14	20	13-1/2	1-3/8	21-3/4	1/2	215
16	16	22	13-1/2	1-3/8	21-3/4	3/8	176
16	16	22	13-1/2	1-3/8	21-3/4	1/2	240
18	18	24	13-1/2	1-3/8	21-3/4	3/8	195
18	18	24	13-1/2	1-3/8	21-3/4	1/2	260
20	20	26	13-1/2	1-3/8	21-3/4	3/8	216
20	20	26	13-1/2	1-3/8	21-3/4	1/2	288
22	22	28	13-1/2	1-3/8	21-3/4	3/8	230
22	22	28	13-1/2	1-3/8	21-3/4	1/2	307
24	24	30	13-1/2	1-3/8	21-3/4	3/8	248
24	24	30	13-1/2	1-3/8	21-3/4	1/2	330
26	26	32	13-1/2	1-3/8	21-3/4	3/8	315
26	26	32	13-1/2	1-3/8	21-3/4	1/2	350

Material Specifications	
Body	High strength, low carbon steel meeting ASTM A572 GR 50 / ASTM A588

Dimensions are in inches unless otherwise noted.

NOTE: Larger diameters available upon request. Please consult factory with your particular application requirements.

* 2" and 3" sizes have minimum yield strength of 35,000 psi.

Style 220-S Reinforcing Sleeves

For smaller diameter repair from 3/4" to 2" ID

The Dresser Style 220-S reinforcing sleeve is a weld-over sleeve for reinforcing threaded collars, welded joints or compression couplings on small diameter pipe from 3/4" ID through 2" ID sizes. The sleeves are made to rigid Dresser specifications meeting ASTM-A513, GR1015 specs, and have a yield strength of 35,000 PSI, and an ultimate strength of 48,000 PSI.

Style 220-S sleeves are furnished in matched halves and all longitudinal edges are factory beveled for welding. A drilled vent hole precludes pressure build-up between sleeve and pipe during welding. Style 220-S sleeves are rated at 350 PSI working pressure and meet the requirements applicable to DOT #192 codes.

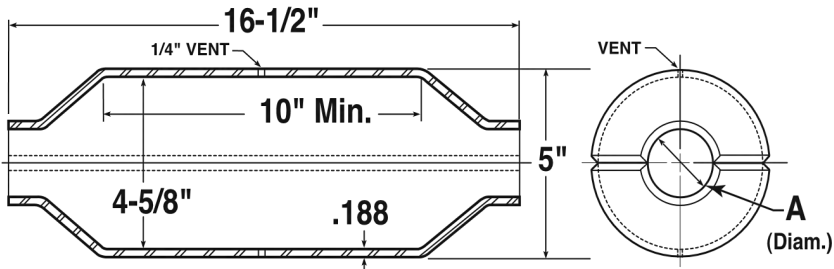

Pipe Size (OD)	Nominal Size	Diameter (A)
1.050	3/4	1-1/8
1.315	1	1-3/8
1.660	1-1/4	1-3/4
1.990	1-1/2	2
2.375	2	2-7/16

All dimensions are in inches unless otherwise noted.

Dresser Product Coatings

ALCLAD™ Epoxy Coating

Dresser Epoxy is a thermoset, fusion-bonded, grey coating and has outstanding physical properties and can be utilized in many piping system applications due to such features as:

- High coating dielectric strength.
- Excellent disbondment resistance in cathodically protected systems.
- Resistant to soil stress and fungi.
- Excellent adhesion in an oven-cured factory application.

All constituents of the epoxy cured film are FDA approved for exposure to fluids for human consumption. ALCLAD also provides an excellent coating for use on components of cathodic protected distribution systems. Thermoset epoxy coatings meet DOT and Federal regulation 192.461. Please consult the factory for special line content applications.

Dresser RED-D Shopcoat

Dresser Shopcoat paint is a waterborne finish, pigmented with red oxide. RED-D provides a suitable base over which primers and final coatings can be applied.

Dresser shopcoat provides a smooth, clean, non-greasy, non-sticky surface and protects all products from corrosion in normal storage situations. It is compatible with primer and enamel coatings of either hard or soft grades of plasticized or unplasticized coal tar enamels, and with asphalt coatings.

For above ground, Dresser Shopcoat will take most of the usual types of paint, including paints with color added, without bleeding through.

Applicable Warnings for Dresser Repair Products

Split Sleeves

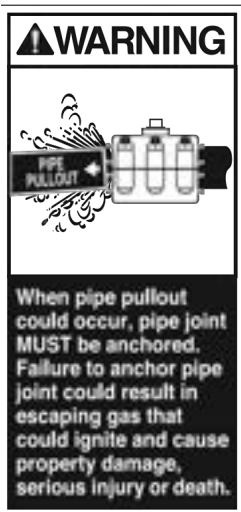

Bell Joint Clamps

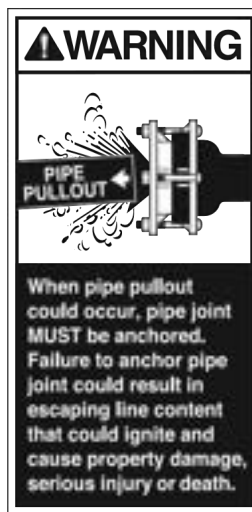

NOTE: Always read the product installation instructions before installing any Dresser products.

Visit us at: www.dresserutility.com

Dresser Utility Solutions reserves the right to make changes in specifications and features shown herein, or discontinue the product described at any time without notice or obligation. Contact your Dresser sales representative for the most current information.

Dresser Pipeline Solutions

41 Fisher Avenue
Bradford, PA 16701
T: 814.362.9200
F: 814.362.9344

© 2023 Natural Gas Solutions North America, LLC – All rights reserved. Natural Gas Solutions reserves the right to make changes in specifications and features shown herein, or discontinue the product described at any time without notice or obligation. Contact your Dresser Natural Gas Solutions representative for the most current information. The Dresser Logo and all Trademarks containing the term "Dresser" are the property of Dresser, LLC, a subsidiary of Baker Hughes.



Water Repair Products DPS.007c

03.25