

RB 2000

Light Commercial & Commercial Regulator

The RB 2000 regulator is designed for applications and for all installations with continuous consumption or rapid flow rate variations, such as burners, industrial ovens, boilers, etc. It is suitable for installation in cabinets, as a space saving regulator.

KEY Benefits

- Balanced valve design eliminates inlet pressure effect
- Rugged construction for durability
- Rapid response to load changes
- Built-in shut-off valve
- Internal relief
- Inlet strainer

Description

The RB 2000 regulator is a direct-acting, spring-loaded regulator (lever type) with a built-in relief valve and optional safety shut-off device.

The balanced valve ensures constant outlet pressure when the upstream pressure varies.

This eliminates changes to the orifice size arising from different inlet pressure ranges.

The regulator is equipped with a built-in filter (filtration grade 0.5 mm).

The safety shut-off valve cuts the gas flow when the outlet pressure exceeds the set pressure (OPSO) or when it drops below the set value (UPSO). It remains closed until the valve is reset manually.

The relief valve avoids triggering the safety shut-off valve in case of thermal expansion, transient surges of pressure, and creep leaks from the regulator. The relief pressure is pre-set at the factory.

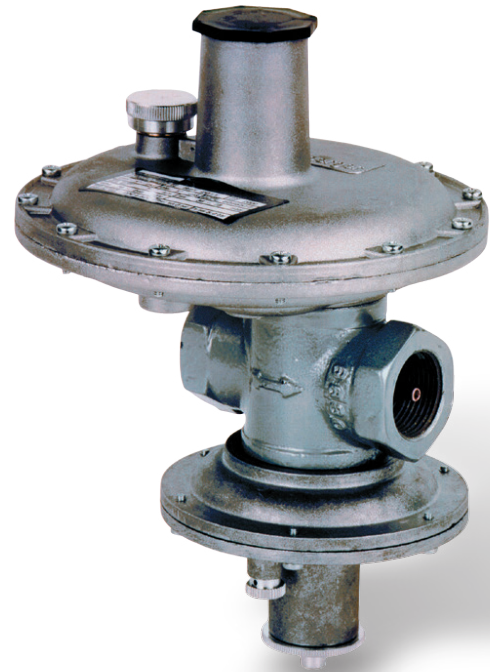

Technical Features

Maximum inlet pressure	10 bar
Outlet pressure	5 mbar - 180 mbar - Extended range up to 750 mbar
Accuracy & lock-up pressure	Up to AC5 / up to SG 10
Operating temperature	-20°C to +60°C
Ambient temperature	-30°C to +60°C (body material)
Acceptable gases	Natural gas, town gas, propane, butane, air, nitrogen, Hydrogen (upto 30%) or any non-corrosive gas
Installation	Horizontal or vertical
Safety devices	Standard relief valve Optional built-in safety shut-off valve: - over-pressure shut-off (OPSO) - under-pressure shut-off (UPSO)
Options	Internal or external sensing line Monitor version

Sizes & Connections

Sizes	1" x 1" - 1" x 1 1/2"
Type	Parallel internal thread according to ISO 228/1 or ISO 7/1

Materials

Body	Spheroidal graphite iron EN 1563 grade EN-GJS-400-15
Head	Die cast aluminium
Internal parts	Stainless steel and brass
Seals	Nitrile rubber
Diaphragm	Rubberized fabric

Operational Diagram

RBI 2312 Type

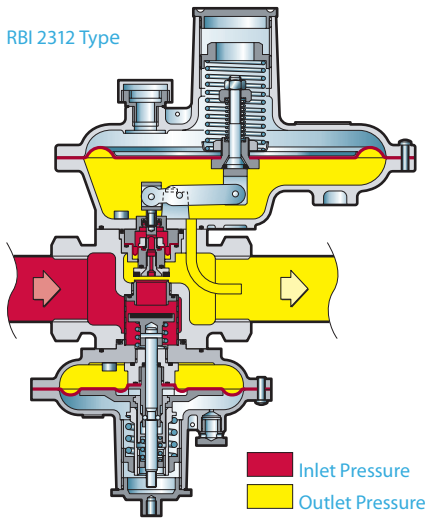

Type Designation and Options

To specify the version of the RB 2000 regulator to be ordered, select the options and relevant codes from the table below.

R	B	X	2	X	1	X	X	X	Variants
									E External sensing line
									I Internal sensing line
							3		Size 1" x 1"
							6		Size 1" x 1 1/2"
								0	Relief valve
								1	Relief valve + Over-pressure shut-off valve
								2	Relief valve + Over and low-pressure shut-off valve
								M	Monitor version
								TR	Reduced head (see spring selection tables)

Example: RBE2312/TR is a 2300 regulator with a balanced valve, an external sensing line, a reduced head and an OPSO / UPSO shut-off valve.

Outlet Pressure Range Regulator

Spring Code	Spring Characteristic				Spring Range	
	d (mm)	De (mm)	Lo (mm)	Lt	2300-2600	2300-2600 TR
20564241	1.5	30	80	9.5	6 - 10 mbar	•
20564141	1.6	30	80	9.5	8 - 13 mbar	•
20564142	1.8	30	80	8.5	13 - 25 mbar	•
20564050	1.8	30	100	10	20 - 28 mbar	•
20564051	2	30	100	11.5	26 - 39 mbar	•
20564044	2.2	30	80	9	36 - 50 mbar	70-130 mbar
20564042	2.5	30	80	9	46 - 80 mbar	125-215 mbar
20564043	2.5	30	80	7	80 - 110 mbar	180-280 mbar
20564143	3	30	80	9	100 - 180 mbar	260-420 mbar
20564144	3.5	30	80	9	•	400- 750 mbar

Safety Shut-off Valves

Over-Pressure Shut-off Springs (OPSO)

When Also Fitted With UPSO Spring*

Spring Code	Spring Characteristic				Spring Range		Spring Range	
	d (mm)	De (mm)	Lo (mm)	Lt	2311-2611	2311-2611 TR	2312-2612	2312-2612 TR
20563022	1.5	25	35	5.5	20 - 60 mbar	•	28 - 60 mbar	•
20563023	1.7	25	35	5.5	30 - 90 mbar	90 - 130 mbar	40 - 90 mbar	90 - 130 mbar
20563014	1.9	25	35	5.5	60 - 130 mbar	120 - 180 mbar	70 - 130 mbar	120 - 180 mbar
20563124	2.2	25	35	5.5	70 - 220 mbar	160 - 330 mbar	120 - 220 mbar	160 - 330 mbar
20563121	2.5	25	35	5.5	150 - 400 mbar	300 - 600 mbar	220 - 420 mbar	300 - 660 mbar
20563115	3	25	35	5.5	•	580 - 1000 mbar	•	640 - 1000 mbar

*the space available for the OPSO spring is reduced by the UPSO spring assembly

Under-Pressure Shut-off Springs (UPSO)

Spring Code	Spring Characteristic				Spring Range	
	d (mm)	De (mm)	Lo (mm)	Lt	2312-2612	2312-2612 TR
20560522	0.7	10	20	7	4 - 14 mbar	•
20560511	0.8	10	20	7	10 - 25 mbar	•
20560515	0.8	10	30	10	20 - 27 mbar	•
20560518	0.9	10	30	10	37 - 45 mbar	•
20560516	1	10	30	10	•	26 - 57 mbar

955-201-17	0.9	10.4	28	7	•	13 - 50 mbar
20560520	1	10.3	25	7.5	45 - 75 mbar	•
20560521	1.3	15	40	9.5	•	60 - 90 mbar
20560517	1.2	10	30	10	•	85 - 170 mbar
20560519	1.4	10	30	10	•	150 - 300 mbar

Relief Valve

The built-in relief valve is set 15 mbar (head 180) or 50 mbar (head 180 TR) above the outlet pressure setting. Other settings on request.

Flow Capacity

Inlet Pressure	Capacities in m ³ /h at Standard Conditions Outlet Pressure Setting				
	20 mbar	50 mbar	100 mbar	300 mbar	500 mbar
RBI 2312 - 1" x 1" (with SSV)					
0.35 bar	70	80	70	-	-
0.5 bar	90	95	90	50	-
0.7 bar	65	115	110	70	-
1 bar	40	120	130	100	80
1.5 bar	35	110	130	140	130
2 bar	35	110	130	150	150
4 bar	35	80	120	150	170
8 bar	35	80	110	115	190

RBI 2612 - 1" x 1 1/2" (with SSV)

0.35 bar	65	80	65	-	-
0.5 bar	90	95	80	50	-
0.7 bar	115	120	115	75	-
1 bar	115	130	130	110	90
1.5 bar	90	130	130	150	130
2 bar	115	130	130	180	170
4 bar	100	130	130	180	200
8 bar	80	130	130	180	200

Maximum capacities at 20% drop or boost.

- The values given are those for appropriately sized pipe work.

Flow CAPACITY

The wide-open flow capacity may be calculated using the following formula:

- In critical flow conditions:
$$Q = \frac{160 \cdot P_u}{2} \sqrt{\frac{P_u - P_d}{P_u}}$$
- In non-critical flow conditions:
$$Q = \frac{160 \cdot P_d}{2} \sqrt{\frac{P_u - P_d}{P_u}}$$

Spring characteristics:

d: wire diameter Lo: height
De: external diameter Lt: no. of spires

Standard conditions:

- Absolute pressure of 1.013 bar
- Temperature of 15°C

Correction factor for non-natural gas applications:

The flow rates are indicated for a 0.6 specific gravity gas. To determine the volumetric flow rate for gases other than natural gas, multiply or calculate the values in the capacity tables using the sizing equations with a correction factor.

The table below lists correction factors for some common gases:

Gas type	Specific gravity	Correction factor
Air	1.00	0.77
Butane	2.01	0.55
Carbon dioxide (dry)	1.52	0.63
Carbon monoxide (dry)	0.97	0.79
Natural gas	0.60	1.00
Nitrogen	0.97	0.79
Propane	1.53	0.63
Propane-Air mix	1.20	0.71

Specific gravity or relative density (air = 1, non-dimensional value)

Use the following formula to calculate the correction factor for gases not listed above. In the formula, d is the specific gravity of the gas.

$$\text{Correction factor} = \sqrt{\frac{0.6}{d}}$$

where:

Q = maximum flow capacity (Sm³/h)
P_u = absolute inlet pressure in bar
P_d = absolute outlet pressure in bar

Overall Dimensions (mm)

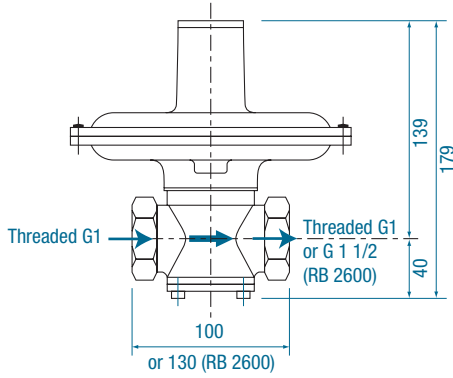

RB 2000 Without Safety Shut-off Valve - Weight 2 kg

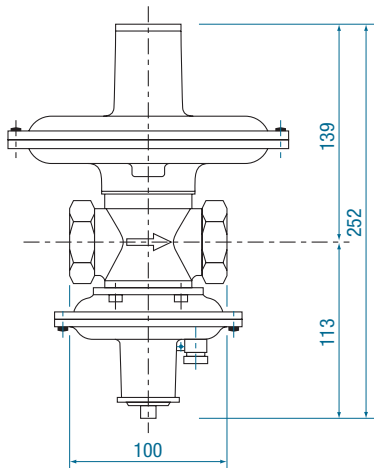
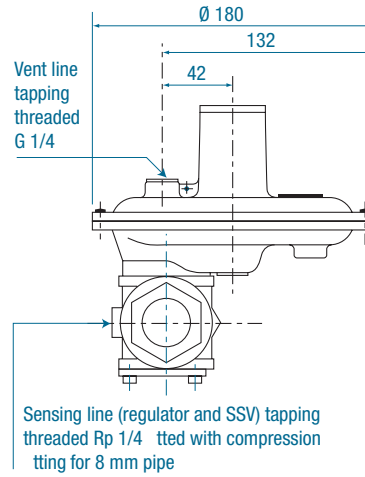

RB 2000 With Safety Shut-off Valve - Weight 2.5 kg

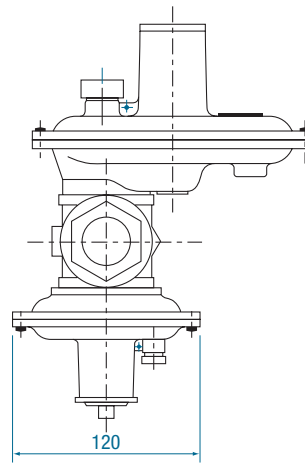

Installation

- The RB 2000 regulator can be mounted in any horizontal or vertical position
- RB 2000 can be used as monitor regulator, upstream from an active regulator. In that case, the external sensing line must be connected downstream from the regulator to be controlled.

Information to be specified when ordering:

- Regulator type code
- Minimum and maximum inlet pressures
- Outlet pressure range setting
- Outlet pressure setting
- Maximum flow rate
 - OPSO setting*
 - UPSO setting*

*(if requested)

Dresser Utility Solutions GmbH

Hardeckstr. 2
76185 Karlsruhe
T: +49 (0)721 / 5981 - 100
info.karlsruhe@dresserutility.com



© 2023 Dresser Utility Solutions GmbH – All rights reserved. Dresser Utility Solutions reserves the right to make changes in specifications and features shown herein, or discontinue the product described at any time without notice or obligation. Contact your Dresser Utility Solutions representative for the most current information. The Dresser Logo and all Trademarks containing the term "Dresser" are the property of Dresser, LLC, a subsidiary of Baker Hughes. Actaris™ is a trademark owned by Itron, Inc. and used under license.