

G65 and G100

Diaphragm Meters



The diaphragm meters G65 and G100 are designed for industrial applications. The design is based on high measuring accuracy and a long lifetime and are maintenance free. This performance is made possible through the principle of two measuring chambers, which are driven by the pressure of the gas. The measured volume is displayed on a numeric totalizer.

Key Benefits

- » Long term accuracy and reliability
- » Robust, maintenance free meter
- » MID approved
- » Wide measuring range
- » Low pressure loss

Technical Specifications

Measuring Range	G65	Qmin 0.65 m ³ /h Qmax 100 m ³ /h
	G100	Qmin 1.00 m ³ /h Qmax 160 m ³ /h
European Metrological Approval (04/22/EC)	Approval N° DE-10-MI002-PTB004 Rev.1	
Temperature Range	Operation temperature: -25 °C to +55 °C. Storing temperature: -40 °C to +70 °C.	
Maximum Working Pressure	500 mbar	
High Temperature Loading (HTL)	The meter can be delivered, as an option, with a HTL version PN0.1	
Connections	Double and single flange connections, DN80 for G65 and DN100 for G100	
Totalizer	Equipped with a magnetic coupling 8-digit index with IP 54 protection UV resistant cover Fitted with a reflecting disc in the first drum to facilitate periodical checks	
Reverse flow device	The meter is equipped with a device which prevents registration of reverse flow	
Housings	Welded (G65 single pipe & G100) or Drawn (G65 double pipe) with powder coating	
Colour	Light grey RAL 7035	



Single Pipe welded type



Double Pipe drawn type

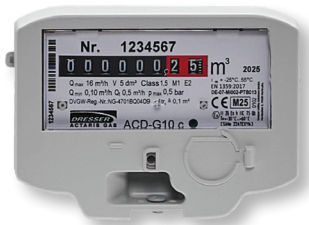

Totalizer with Cyble target

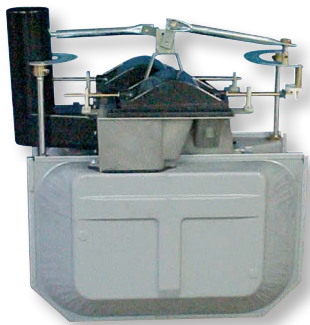

Measuring unit



Totalizer with LF "cable"



Totalizer with Double LF "Binder plug"

Technical design

Totalizer

A register driven by a magnetic coupling indicates the gas consumption. Our index box-construction is designed in such a way that it's impossible to access the registers without damaging them.

Measuring unit

The measuring unit consists of two chambers with synthetic and gas-tight diaphragms, which is moved by the differential between the inlet and outlet pressure. A transmission gear and a magnetic coupling transfer the reciprocating motion to the mechanical index.

The unit is built in a robust steel coated casing, either drawn or welded.

Accuracy

In accordance with the MID and OIML standards.

In line with MID standards, the tolerance of acceptance is $\pm 3\%$ from Q_{min} to $0.1 Q_{max}$ and $\pm 1.5\%$ from $0.1 Q_{max}$ to Q_{max} .

Typical error curve

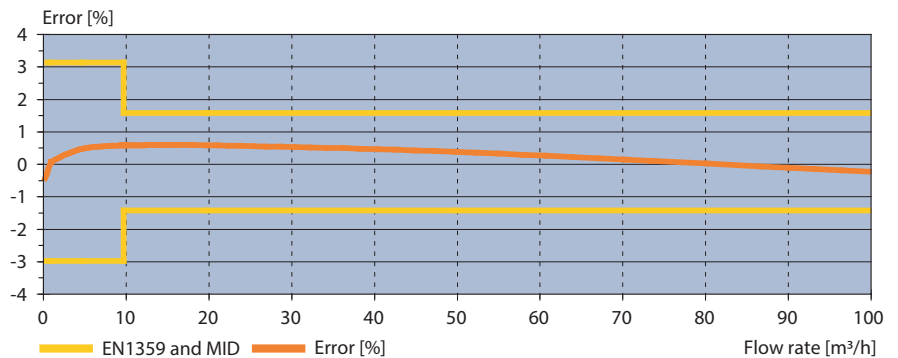

Every meter undergoes a 100 % inspection for function, accuracy and safety. All meters are EN1359 compliant and have DVGW approval.

LF pulse-emitter

Meter versions with the sardine index box are standard equipped with a LF pulse-emitter.

1 pulse is 0.1 m^3 (G65) or 1 m^3 (G100).

The 4 pins male-connector is fixed in a "D"-hole in the index box. The female connector is supplied with each meter.

The index box is available with a permanent magnet in one of the index drums as standard and can be refitted with a pulse transmitter (reed switch).

G65-G100 vertical version

Dimensions and Technical Data

Type	Nozzle Type	Qmin m ³ /h	Qmax m ³ /h	Vol- dm ³	Pmax bar	Flange DN	a mm	b mm	c mm	d mm	h mm	Weight kg
G65	Drawn	0.65	100	55	0.5	80	500	700	217	445	692	48
G65	Drawn	0.65	100	55	0.5	80	640	840	216	445	795	52
G65	Welded - EP	0.65	100	55	0.5	80	N/A	700	216	436	737	71
G100	Welded	1	160	123	0.5	100	675	894	257	532	885	105
G100	Welded	1	160	123	0.5	100	710	894	257	532	885	105
G100	Welded - EP	1	160	123	0.5	100	N/A	894	257	532	920	113

EP=Single nozzle.

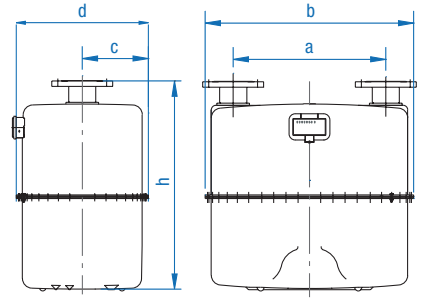

G65b Double pipe Drawn (500)

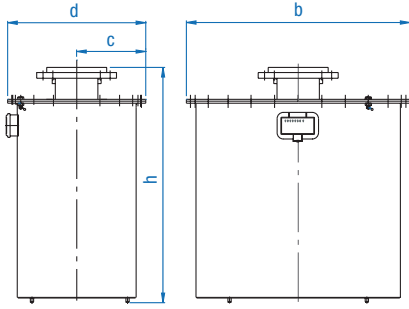

Single Pipe Welded

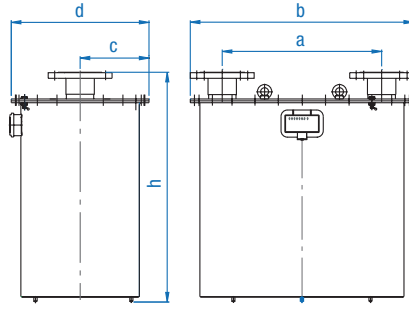

G100 Double Pipe Welded (675)

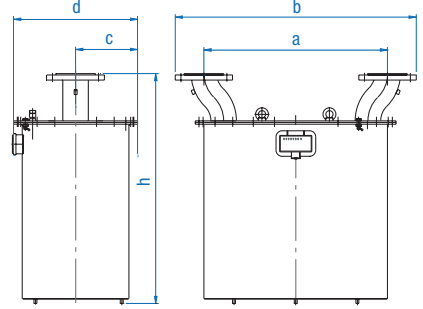

G100 Double Pipe Welded (710)

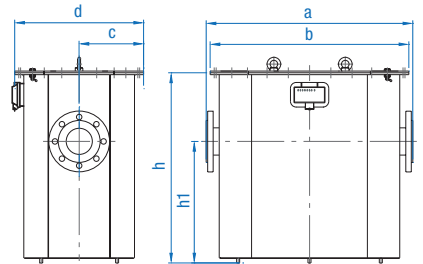

G65 horizontal version

G65 horizontal version

Dimensions and Technical Data

Type	Nozzle Type	Qmin m ³ /h	Qmax m ³ /h	Vol- dm ³	Pmax bar	Flange DN	a mm	b mm	c mm	d mm	h' mm	h mm	Weight kg
G65	Welded	0.65	100	55	0.5	80	680	654	212	432	400	626	69

Options

On request the following options are possible

- » AMR/AMI solution: Totalizer pre-equipped with a Cyble target
- » Thermowell (second one for reference measurements on special request)
- » Other flange dimensions
- » Pressure tapping point
- » Retrofittable Low Frequency (LF) transmitter in different versions (Cable, Binder plug)

Information to be specified when ordering:

- » Nature of gas
- » Measuring range (G65 or G100)
- » Specific marking (serial number, customer logo, bar code)
- » Maximum working pressure
- » Version (horizontal or vertical)
- » Meter interaxis and connection type
- » Accessories and options

Dresser Utility Solutions GmbH

Hardeckstr. 2
76185 Karlsruhe
T: +49 (0)721 / 5981 - 0
info.karlsruhe@dresserutility.com



© 2025 Dresser Utility Solutions GmbH – All rights reserved. Dresser Utility Solutions reserves the right to make changes in specifications and features shown herein, or discontinue the product described at any time without notice or obligation. Contact your Dresser Utility Solutions representative for the most current information. The Dresser Logo and all Trademarks containing the term "Dresser" are the property of Dresser, LLC, a subsidiary of Baker Hughes. Actaris™ is a trademark owned by Itron, Inc. and used under license.