

RR 16

Commercial & Industrial Regulator

The RR 16 regulator is designed for industrial use: gas supply networks, district stations, industries, heating plants, as well as for all installations where accurate pressure control, easy adjustment and fast response times are required, such as for burners, industrial ovens, boilers etc.

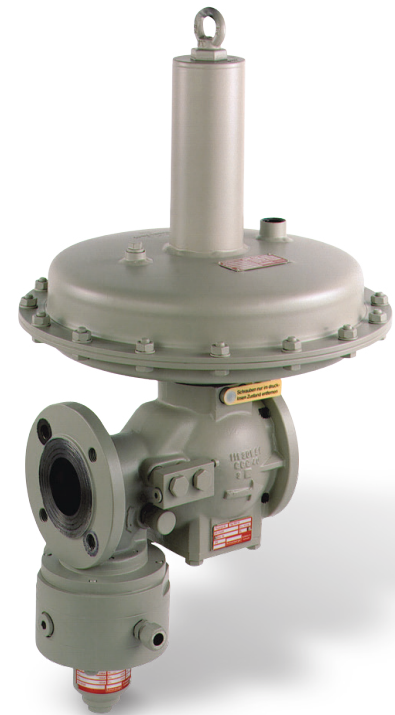

Description

The RR 16 regulator is a direct-acting, spring-loaded regulator with an optional built-in safety shut-off device.

The balanced valve ensures constant outlet pressure when the upstream pressure varies.

Key Benefits

- » Built-in resistance
- » Cartridge type diaphragm and valve assembly for easy maintenance
- » Wide range of interchangeable orifices
- » Approved by German DVGW

Technical Features

Maximum inlet pressure	16.0 bar
Outlet pressure	10 mbar - 1.1 bar
Accuracy & lock-up pressure	Up to AC5 / up to SG 10
Operating temperature	Gas: -20° C to +60° C Ambient: -30°C to + 60°C
Acceptable gases	Natural gas, propane, butane, air, nitrogen and all non-corrosive gases
Safety devices	Optional built-in safety shut-off valve OPSO: Over-pressure shut-off UPSO: Under-pressure shut-off
Options	Built-in silencer Monitor version

Sizes & Connections

Sizes	DN 25, DN 50, DN 80
Body lengths	See table page 4
Flanges	PN 16

Materials

Body	Spheroidal graphite cast iron EN-GJS-400-18-LT
Actuator	Steel S235 JR
SSV actuator	Brass, steel and aluminium
Internal parts	Steel, zinc-coated / Stainless steel
Seals	NBR rubber / Viton
Diaphragm	NBR rubber / NBR rubber, reinforced fabric

Operational Diagram

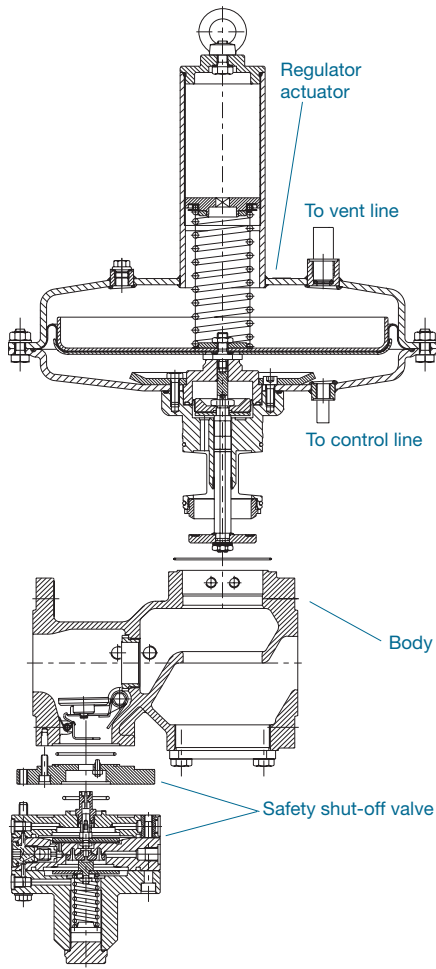

RR16 regulator with SL-IZ safety shut-off valve
Cross-section

Accuracy Class (AC), lock-up pressure class (SG) and lock-up pressure zone (SZ):

- » 10 - 20 mbar: AC 20 / SG 30
- » 20 - 100 mbar: AC 10 / SG 20
- » 100 mbar: AC 5 / SG 10

The typical lock-up pressure zone is SZ 10.
Reduced zone is available on request.

where:

Q = volumetric flow rate in m³/h at standard conditions
 P_u = absolute inlet pressure in bar
 P_d = absolute outlet pressure in bar

Outlet Pressure Range Regulator

RR16

Size	Actuator Size	Spring Code	Spring Color	Wire (Ø mm)	Spring Range
DN 25	8N - Ø 310	955-202-70	red	3	10 - 25 mbar
		955-202-77	brown	3.8	20 - 55 mbar
		955-202-78	blue	4.5	45 - 110 mbar
		955-202-79	green	5.6	90 - 230 mbar
		955-202-80	orange	6.3	200 - 330 mbar
		955-202-81	black	7	300 - 450 mbar
8H - Ø 310	8H - Ø 310	955-202-82	yellow	9.5	300 - 650 mbar
		955-202-83	grey	11	600 - 1100 mbar
DN 50 & 80	12N - Ø 405	955-202-77	brown	3.8	10 - 25 mbar
		955-202-78	blue	4.5	20 - 55 mbar
		955-202-79	green	5.6	45 - 115 mbar
		955-202-80	orange	6.3	100 - 160 mbar
		955-202-81	black	7	150 - 225 mbar
		955-202-81*	green	5.6	90 - 230 mbar
8N - Ø 310	8N - Ø 310	955-202-80	orange	6.3	200 - 330 mbar
		955-202-81	black	7	300 - 450 mbar
8H - Ø 310	8H - Ø 310	955-203-73**	red	8.0	130 - 350 mbar
		955-202-82	yellow	9.5	300 - 650 mbar
		955-202-83	grey	11	600 - 1100 mbar

* When the regulator is fitted with this spring, the accuracy class becomes AC20 instead of AC 10.
 ** Special spring.

Note:

For better accuracy, choose the largest actuator size.
 8N actuator offers a reduced overall dimension for compact installation.

FLOW CAPACITY

Flow Coefficient

The RR 16 regulator can be fitted with an orifice of various sizes in order to match the capacity requirements. Large orifices offer extra-large flow rate possibilities, but are not recommended for high inlet pressures.

Regulator Size	Orifice Size	Max. Inlet Pressure	Flow* Coefficient Kg
DN 25	24 mm	16 bar	210
	31 mm**	16 bar	430
DN 50	24 mm	16 bar	450
	31 mm**	16 bar	580
	42 mm**	16 bar	1000
	54 mm	5 bar	1440
DN 80	42 mm	16 bar	1400
	54 mm**	16 bar	2300
	82 mm	4 bar	3440

* The flow coefficient is calculated for a regulator in the fully opened position.

** When using this orifice, the accuracy classes as indicated are valid if the inlet pressure variation does not exceed 10 bar.

Sizing Equation

For a 0.6 specific gravity gas, the wide-open orifice flow (Q) may be calculated using the following equations:

- » Sub-critical flow behaviour: $Q = K_G \sqrt{P_d(P_u - P_d)}$ where $(P_u - P_d) \leq 0.5 P_u$
- » Critical flow behaviour: $Q = K_G P_u / 2$ where $(P_u - P_d) > 0.5 P_u$

Capacity Tables

Inlet Pressure	Outlet Pressure Setting (mbar)	Capacities at Standard Conditions (m³/h)								
		Orifice Size								
		DN 25 24 mm	DN 25 31 mm	DN 50 24 mm	DN 50 31 mm	DN 50 42 mm	DN 50 54 mm	DN 80 42 mm	DN 80 54 mm	DN 80 82 mm
100 mbar	20	60	125	130	165	180	360	405	660	900
	50	48	100	105	135	150	190	325	530	810
200 mbar	20	91	185	195	250	360	615	610	990	1365
	50	84	170	180	230	330	460	565	920	1185
	100	70	145	150	195	250	295	470	770	990
400 mbar	20	130	270	280	365	610	885	885	1440	2070
	50	130	260	275	355	590	800	860	1400	1950
	100	120	250	260	335	560	700	815	1330	1710
	200	105	210	220	285	400	430	695	1130	1300
700 mbar	20	175	360	375	485	860	1225	1180	1925	2835
	50	175	355	375	480	835	1150	1170	1910	2700
	100	170	350	365	475	810	1070	1150	1880	2380
	200	165	335	350	450	630	800	1070	1790	2080
	400	135	280	290	375	470	590	920	1500	1670
1 bar	20	210	430	450	585	1060	1455	1420	2315	3465
	50	210	430	450	580	1060	1455	1415	2310	3380
	100	210	430	450	580	990	1380	1410	2300	3060
	200	205	425	445	570	800	1035	1390	2265	2790
	400	190	395	415	535	710	880	1300	2120	2100
	700	150	310	320	415	530	650	1010	1650	1950
2 bar	20	315	645	675	875	1510	2065	2125	3465	5220
	50	315	645	675	875	1510	2065	2125	3465	5220
	100	315	645	675	875	1490	1980	2125	3465	3690
	200	315	645	675	875	1345	1605	2125	3465	3420
	400	315	645	675	875	1180	1260	2125	3465	3060
	700	315	640	670	865	1015	1185	2105	3430	3060
	1000	300	610	640	820	910	1060	2000	3265	3060
	1000	300	610	640	820	910	1060	2000	3265	3060
3 bar	20	420	860	900	1000	1900	2600	2830	4615	6480
	50	420	860	900	1165	1900	2600	2830	4615	6480
	100	420	860	900	1165	1900	2600	2830	4615	5100
	200	420	860	900	1165	1900	2140	2830	4615	4900
	400	420	860	900	1165	1600	1605	2830	4615	4250
	700	420	860	900	1165	1410	1530	2830	4615	4250
	1000	420	860	900	1165	1370	1420	2830	4615	4250
	1000	420	860	900	1165	1370	1420	2830	4615	4250
4 bar	20	480	900	1130	1100	2230	3060	3535	5765	7650
	50	525	1080	1130	1300	2230	3060	3535	5765	7650
	100	525	1080	1130	1455	2230	3060	3535	5765	5900
	200	525	1080	1130	1700	2230	3060	3535	5765	5500
	400	525	1080	1130	1700	2230	3060	3535	5765	5100
	700	525	1080	1130	1700	2230	3060	3535	5765	5100
	1000	525	1080	1130	1700	2230	3060	3535	5765	5100
	1000	525	1080	1130	1700	2230	3060	3535	5765	5100
7 bar	20	760	1200	1800	2325	3200	●	5650	9250	●
	50	840	1500	1800	2325	3200	●	5650	9215	●
	100	840	1500	1800	2325	3200	●	5650	9215	●
	200	840	1500	1800	2325	3200	●	5650	9215	●
	400	840	1500	1800	2325	3200	●	5650	9215	●
	700	840	1500	1800	2325	3200	●	5650	9215	●
	1000	840	1500	1800	2325	3200	●	5650	9215	●
10 bar	20	860	1200	2480	3195	3980	●	7765	12665	●
	50	1030	1700	2480	3195	3980	●	7765	12665	●
	100	1080	1700	2480	3195	3980	●	7765	12665	●
	200	1155	2370	2480	3195	3980	●	7765	12665	●
	400	1155	2370	2480	3195	3980	●	7765	12665	●
	700	1155	2370	2480	3195	3980	●	7765	12665	●

Standard conditions:

- Absolute pressure of 1.013 bar
- Temperature of 15°C

Capacities are indicated for a regulator with a built-in safety shut-off valve. When a noise abatement device is built into the regulator as well, the values mentioned in the tables -- or calculated from the sizing equation -- should be reduced by 10%.

Correction factor for non-natural gas applications:

The flow rates are indicated for a 0.6 specific gravity gas. To determine the volumetric flow rate for gases other than natural gas, multiply or calculate the values in the capacity tables using the sizing equations with a correction factor.

The table below lists correction factors for some common gases:

Gas type	Specific gravity	Correction factor
Air	1.00	0.77
Butane	2.01	0.55
Carbondioxide (dry)	1.52	0.63
Carbon monoxide (dry)	0.97	0.79
Natural gas	0.60	1.00
Nitrogen	0.97	0.79
Propane	1.53	0.63
Propane-Air mix	1.20	0.71
Natural gas +20% H2	0.50	1.10

Specific gravity or relative density (air = 1, non-dimensional value)

Use the following formula to calculate the correction factor for gases not listed above. In the formula, d is the specific gravity of the gas.

$$\text{Correction factor} = \sqrt{\frac{0.6}{d}}$$

Do not operate the orifice in the inlet pressure areas marked with ●.

Inlet Pressure	Outlet Pressure Setting (mbar)	Capacities at Standard Conditions (m ³ /h)								
		Orifice Size								
		DN 25 24 mm	DN 25 31 mm	DN 50 24 mm	DN 50 31 mm	DN 50 42 mm	DN 50 54 mm	DN 80 42 mm	DN 80 54 mm	DN 80 82 mm
16 bar	1000	1155	2370	2480	3195	3980	●	7765	12665	●
	20	1210	1700	3000	4935	5360	●	11995	19565	●
	50	1250	2000	3000	4935	5360	●	11995	19565	●
	100	1380	2200	3000	4935	5360	●	11995	19565	●
	200	1500	2500	3000	4935	5360	●	11995	19565	●
	400	1785	3660	3000	4935	5360	●	11995	19565	●
	700	1785	3660	3000	4935	5360	●	11995	19565	●
	1000	1785	3660	3000	4935	5360	●	11995	19565	●

Safety Shut-Off Valve

Selecting the SSV

SSV Type	Max. Operating Pressure	Function	Range Wdso	Wdsu
SL-IZ	Built-in resistance 16 bar	OPSO	35 mbar to 1.7 bar	-
033	5 bar	OPSO	40 mbar to 0.45 bar	-
022	Built-in resistance 16 bar	OPSO and UPSO	40 mbar to 1.7 bar	10 to 220 mbar

Note that OPSO and UPSO settings are adjustable separately.

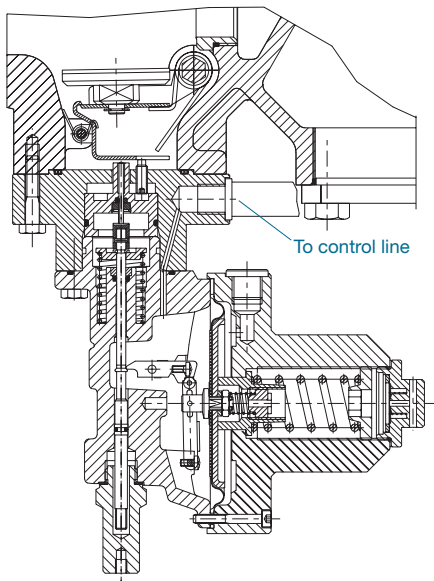

Type 022 Safety Shut-off Valve - Cross-section

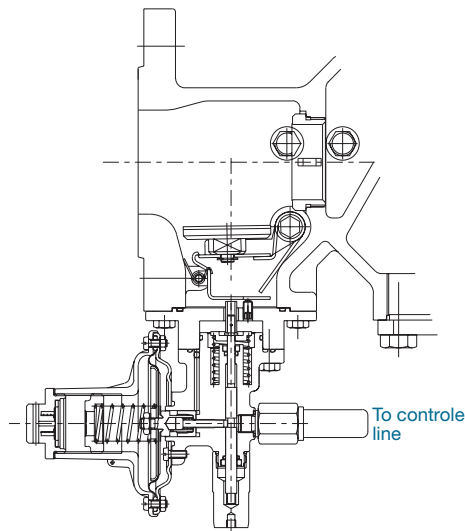

Type 033 Safety Shut-off Valve - Cross-section

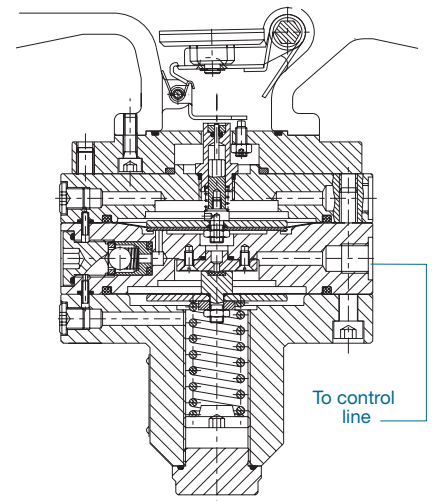

Type SL-IZ Safety Shut-off Valve - Cross-section

Outlet Pressure Range Safety Shut-Off Valves

022

Variant	Spring Code	Spring Color	Wire (Ø mm)	Spring Range
Over Pressure Shut-off (OPSO)	955-200-22	red	1.4	20 - 60 mbar
	955-200-23	blue	1.6	50 - 120 mbar
	955-200-24	green	2.6	100 - 450 mbar
	955-203-41	black	3.2	0.35 - 1.0 bar
	955-203-42	yellow	4.0	0.8 - 1.7 bar
Under Pressure Shut-off (UPSO)	955-200-32	red	0.8	10 - 50 mbar
	955-203-51	brown	1.25	40 - 120 mbar
	955-203-52	yellow	1.6	100 - 220 mbar

033

Over Pressure Shut-off (OPSO)	Spring Code	Spring Color	Wire (Ø mm)	Spring Range
	955-200-22	red	1.4	40 - 70 mbar
	955-200-23	blue	1.6	50 - 150 mbar
	955-200-24	green	2.6	140 - 450 mbar

SL-IZN.1 and SL-IZM.1

Over Pressure Shut-off (OPSO)	Spring Code	Spring Color	Wire (Ø mm)	Spring Range
IZN.1 Head	955-202-36	red	1.8	35 - 250 mbar
	955-202-37	green	2.5	200 - 800 mbar
IZM.1 Head	955-202-38	yellow	3.6	0.6 - 1.7 bar

SL-IZN.1 Accuracy Class (AG):

» OPSO: • 35 - 100 mbar: AG 10

Minimum difference between regulator and SSV settings (ΔP_w):

» 20 mbar for OPSO

SL-IZN.1 or -IZM.1 Accuracy Class (AG):

» OPSO > 100 mbar: • AG 5

Minimum difference between regulator and SSV settings (ΔP_w):

» 20 mbar for OPSO

Accuracy Class (AG):

- » OPSO: • 40 - 400 mbar: AG 10
- 0.4 - 1 bar: AG 5
- 1 - 1.7 bar: AG 2.5
- » UPSO: • 10 - 20 mbar: AG 30
- 20 - 220 mbar: AG 20

Minimum difference between regulator and SSV settings (ΔP_w):

- » 10 mbar for UPSO
- » 20 mbar for OPSO

Accuracy Class (AG):

- » OPSO: • AG 10

Minimum difference between regulator and SSV settings (ΔP_w):

- » 20 mbar for OPSO

Overall Dimensions (mm)

Regulator

DN	Actuating Drive Body	A	B	C	D	E	I	K	L	M	X	Y
25	8 N	310	180	470	525	95	140	90	47	225	575	660
25	8H	310	180	550	610	95	140	90		225	660	765
50	8 N	310	250	485	570	95	200	105	71	240	620	680
50	8 H	310	250	570	650	95	200	105		240	700	785
50	12 N	405	250	485	570	95	200	105		240	620	680
80	8 N	310	300	545	645	95	240	165	90	300	720	735
80	8 H	310	300	630	730	95	240	165		300	805	840
80	12 N	405	300	545	645	95	240	165		300	720	735

Safety Shut-off Valve (SSV)

DN	F SL-IZ N, M	F 022	F 033	G SL-IZ N, M	G 022	H 022 ∅	H 033 ∅	H SL-IZ N, M ∅	I	J SL-IZ N, M	J 022	J 033
25	240	252	195	105	88	114	100	140	140	132	177	140
50	245	255	195	108	93	114	100	140	200	135	182	140
80	285	300	240	151	134	114	100	140	240	178	223	185

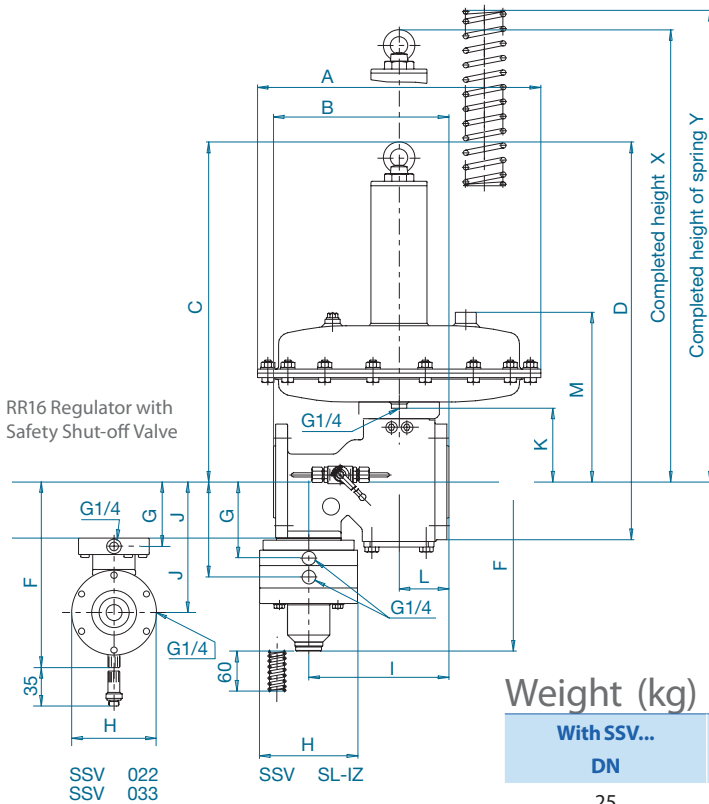

Weight (kg)

With SSV...	SL-IZ			022		
	DN	8N	8H	12N	8N	8H
25	30	36.8	-	26.8	33.6	-
50	35	41.8	45	31.8	38.6	41.8
80	53	59.8	63	49.8	56.6	59.8

Connections

DN	Number of Thread Holes	Thread	Hex Bolt DIN (1) 931-5.6	Hex Nut DIN (1) 934-5
25	4	M 12	M 12 x 40	M 12
50	4	M 16	M 16 x 60 (2)	M 16
80	8	M 16	M 16 x 60 (2)	M 16

(1) Bolts and nuts are not supplied with RR16 regulator
 (2) Screw bolt DIN 2509

Installation

The following drawing shows a model installation for the RR 16 regulator with a built-in safety shut-off valve, Type SL-IZ. The usual position for installation is horizontal.

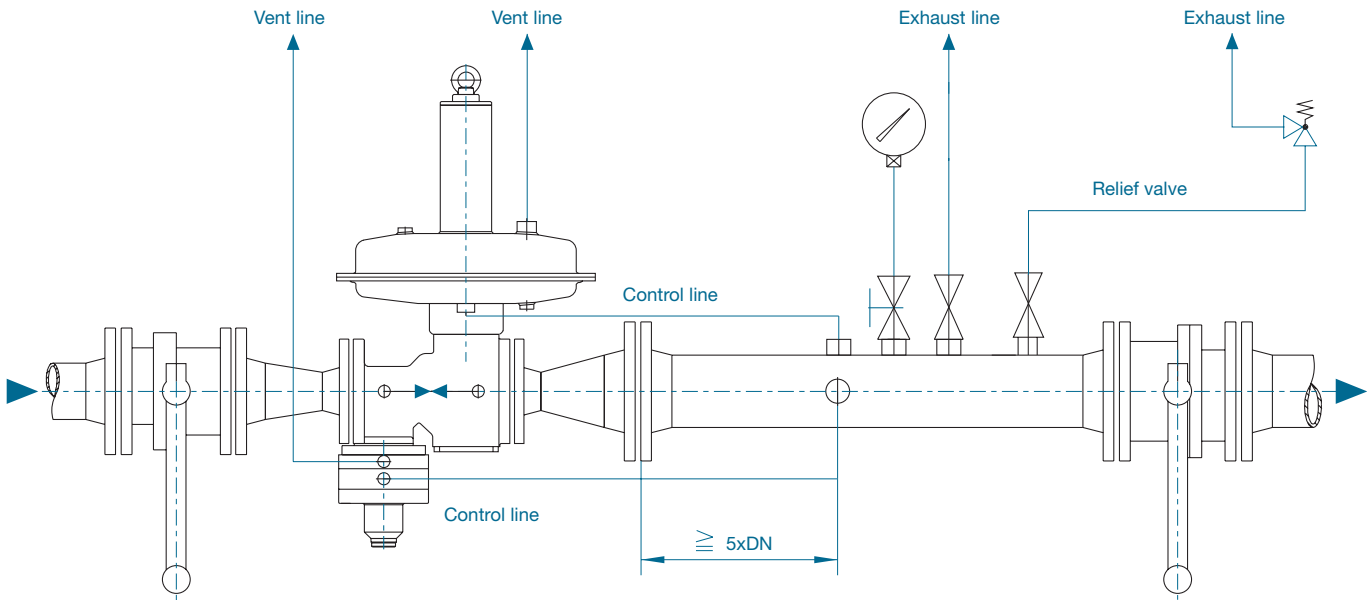

Typical installation

Type Designation

RR16-	XX-	XX-	XXX-	S..-XXX	Variants
	25 50 80				DN size
		24 31 42 54 82			Orifice size (DN 25 & DN 50) (DN 25 & DN 50) (DN 50 & DN 80) (DN 50 & DN 80) (DN 80 only)
			8 N 8 H 12 N		Actuator size
				SL-IZN.1 SL-IZM.1 SSV-033 SSV-022	SSV (OPSO) SSV (OPSO and UPSO)

Options

- » Monitor application: special balanced stem for regulator installed in the upstream monitor position.
 - » Silencer: noise abatement device around the valve seat to reduce the sound pressure level by around 10 dbA.
 - » Valve travel indicator
- SSV options
- » Valve position switch:
Ex proximity switch
 - » Emergency push-button

Information to be specified when ordering:

- » Regulator type code
- » Minimum and maximum inlet pressures
- » Outlet pressure range setting
- » Outlet pressure setting
- » Connection type
- » Options
 - » OPSO setting*
 - » UPSO setting*

* (if requested)

Dresser Utility Solutions GmbH

Hardeckstr. 2
76185 Karlsruhe
T: +49 (0)721 / 5981 - 100
info.karlsruhe@dresserutility.com



© 2024 Dresser Utility Solutions GmbH – All rights reserved. Dresser Utility Solutions reserves the right to make changes in specifications and features shown herein, or discontinue the product described at any time without notice or obligation. Contact your Dresser Utility Solutions representative for the most current information. The Dresser Logo and all Trademarks containing the term "Dresser" are the property of Dresser, LLC, a subsidiary of Baker Hughes. Actaris™ is a trademark owned by Itron, Inc. and used under license.