



RB 4600 Gas Pressure Regulator

3400992805

AE

Instruction Manual

EN	FR	DE	ES	IT	PT
EU DECLARATION OF CONFORMITY	DECLARATION UE DE CONFORMITE	EU KONFORMITÄTS-ERKLÄRUNG	DECLARACIÓN UE DE CONFORMIDAD	DICHIARAZIONE DI CONFORMITÀ UE	DECLARAÇÃO UE DE CONFORMIDADE
Type Designation					
Gas Pressure Regulator					
Name and address of the manufacturer					
Dresser Utility Solutions GmbH, Hardeckstraße 2, 76185 Karlsruhe, Germany					
This declaration of conformity is issued under the sole responsibility of the manufacturer.					
La présente déclaration de conformité est établie sous la seule responsabilité du fabricant.					
Die alleinige Verantwortung für die Ausstellung dieser Konformitätserklärung trägt der Hersteller.					
La presente declaración de conformidad se expide bajo la exclusiva responsabilidad del fabricante.					
La presente dichiarazione di conformità è rilasciata sotto la responsabilità esclusiva del fabbricante.					
A presente declaração de conformidade é emitida sob a exclusiva responsabilidade do fabricante.					
Object of the declaration					
Objet de la déclaration					
Gegenstand der Erklärung					
Objeto de la declaración					
Oggetto della dichiarazione					
Objecto da declaração					

RB4610 / 4620 / 4630 without SSV

RB4611/4612/4621/4622/4631/4632 with SSV8500 or SSV8600

The object of the declaration described above is in conformity with the relevant Union harmonization legislation and the corresponding harmonized standards	L'objet de la déclaration décrit ci-dessus est conforme à la législation communautaire d'harmonisation applicable ainsi qu'aux normes harmonisées associées	Der oben beschriebene Gegenstand der Erklärung erfüllt die einschlägigen Harmonisierungsrechtsvorschriften der Gemeinschaft und den entsprechenden harmonisierten Normen	El objeto de la declaración descrita anteriormente es conforme a la legislación comunitaria de armonización pertinente y las normas armonizadas correspondientes	L'oggetto della dichiarazione di cui sopra è conforme alla pertinente normativa comunitaria di armonizzazione e alle corrispondenti norme armonizzate	O objecto da declaração acima mencionada está em conformidade com a legislação comunitária aplicável em matéria de harmonização e as correspondentes normas harmonizadas
2014/68/EU (PED) -EN 334:2019 -EN 14382:2019 The used fluids are classified in group 1 according to article 13.		OJ L 189, Page 164, 27.04.2014			
2014/30/EU (EMC) -EN 61000-6-2:2019 -EN 61000-6-3:2007/A1:2011/AC:2012		OJ L 96, Page 79, 29.03.2014	only for optional electronic device		
2011/65/EU (RoHS) 2015/863/EU (RoHS) -EN IEC 2018:63000		OJ L 137, Page 10, 04.06.2015			
Certificates issued by the notified body	Certificats délivrés par l'organisme notifié	von der notifizierten Stelle ausgestellte Bescheinigungen	Certificados emitidos por el organismo notificado	Certificati rilasciati dall'organismo notificato	Certificados emitidos pelo organismo notificado
PED	Module D1	TÜV SÜD Industrie Service GmbH (CE 0036); Westendstr. 199, D-80686 München			
Place and date of issue	Date et lieu d'établissement	Ort und Datum der Ausstellung	Lugar y fecha de expedición	Luogo e data del rilascio	Local e data da emissão
		Karlsruhe, 16.11.2023			
Name, Function, Signature	Nom, Fonction, Signature	Name, Funktion, Unterschrift	Nombre, Cargo, Firma	Nome e cognome, Funzione, Firma	Nome, Cargo, Assinatura
			S. Corbière Quality Manager		

HU EU-MEGFELELŐSÉGI NYILATKOZAT	RO DECLARAȚIA UE DE CONFORMITATE	NL EU VERKLARING VAN OVEREENSTEMMING	PL DEKLARACJA ZGODNOŚCI UE	CZ EU PROHLÁŠENÍ O SHODĚ
--	---	---	---	------------------------------------

A gyártó neve és címe	Numele și adresa producătorului	Naam en adres van de fabrikant	Nazwa i adres producenta	Jméno a adresa výrobce
-----------------------	------------------------------------	--------------------------------	--------------------------	------------------------

Ezt a megfelelőségi nyilatkozatot a gyártó kizárólagos felelőssége mellett adják ki.	Această declarație de conformitate este emisă sub responsabilitatea exclusivă a producătorului.	Deze conformiteitsverklaring wordt verstrekt onder de verantwoordelijkheid van de fabrikant.	Ta deklaracja zgodności wydana zostaje na wyłączną odpowiedzialność producenta.	Toto prohlášení o shodě se vydává na výhradní odpovědnost výrobce.
A nyilatkozat tárgya	Obiectul declarației	Onderwerp van de verklaring	Przedmiot deklaracji	Předmět prohlášení

A fent leírt nyilatkozat tárgya összhangban van a vonatkozó uniós harmonizációs jogszabályokkal és a megfelelő harmonizált szabványokkal	Obiectul declarației descrise mai sus este în conformitate cu legislația relevantă de armonizare a Uniunii și cu standardele armonizate corespunzătoare	Het onderwerp van de hierboven beschreven verklaring is in overeenstemming met de relevante harmonisatiewetgeving van de Unie en de overeenkomstige geharmoniseerde normen	Opisany powyżej przedmiot tej deklaracji jest zgodny z odpowiednimi wymaganiami unijnego prawodawstwa harmonizacyjnego	Výše popsaný předmět prohlášení je ve shodě s příslušnými harmonizačními právními předpisy Unie
--	---	--	--	---

bejelentett szervezet által kiállított igazolások	Certificate emise de organismul acreditat	Certificaten afgegeven door de aangemelde instantie	W stosownych przypadkach nazwa, adres i numer jednostki notyfikowanej	Případné certifikáty vydané oznámeným subjektem
---	---	---	---	---

DGR-0036-QS-1164-23

Kiállítás helye és dátuma	Locul și data emiterii	Plaats en datum van uitgifte	miejsce i data wydania	Místo a datum vydání
---------------------------	------------------------	------------------------------	------------------------	----------------------

Név, beosztás, aláírás	Nume, funcție, semnătură	Naam, functie, handtekening	Nazwisko, stanowisko, podpis	Jméno, funkce, podpis
------------------------	--------------------------	-----------------------------	------------------------------	-----------------------

This manual aims to provide relevant information for the installation, commissioning and maintenance of **RB 4600** or regulator.

The **RB 4600** pressure regulator is a combination of active regulator and monitor regulator - both of RB 4700 type - with upstream slam-shut valve.

RB 4700 instruction manual item no 3400992806 on request

It may be fitted with an integrated safety shut-off device type **SSV 8500** or **SSV 8600**.

The operation and maintenance of the latter devices are described in:

- Instruction Manual 3850992802:
Safety Shutoff Valve Series 8500,

or

- Instruction Manual 3850992803:
Safety Shutoff Valve Series 8600.

Technical features

Allowable pressure PS: 25 bar

Inlet pressure p_{umax}: 19 bar

Outlet pressure range **wh**:

- 5 mbar to 13 bar

Accuracy class: up to AC 1

Closing pressure class: up to SG2,5

Operating temperature range:

-20°C to +60°C

- The product is classified along the Pressure Equipment Directive (PED) as Category II

Product classification is based on the following volumes:

DN	25	40	50	80	100
Volume (dm3) carrying inlet pressure					
RB 4600	1,2	2	2,5	6,4	6,4
Volume (dm3) carrying outlet pressure					
RB 4600	1,2	2	2,5	6,4	6,4

Fig 2 - RB 4600 sectional view

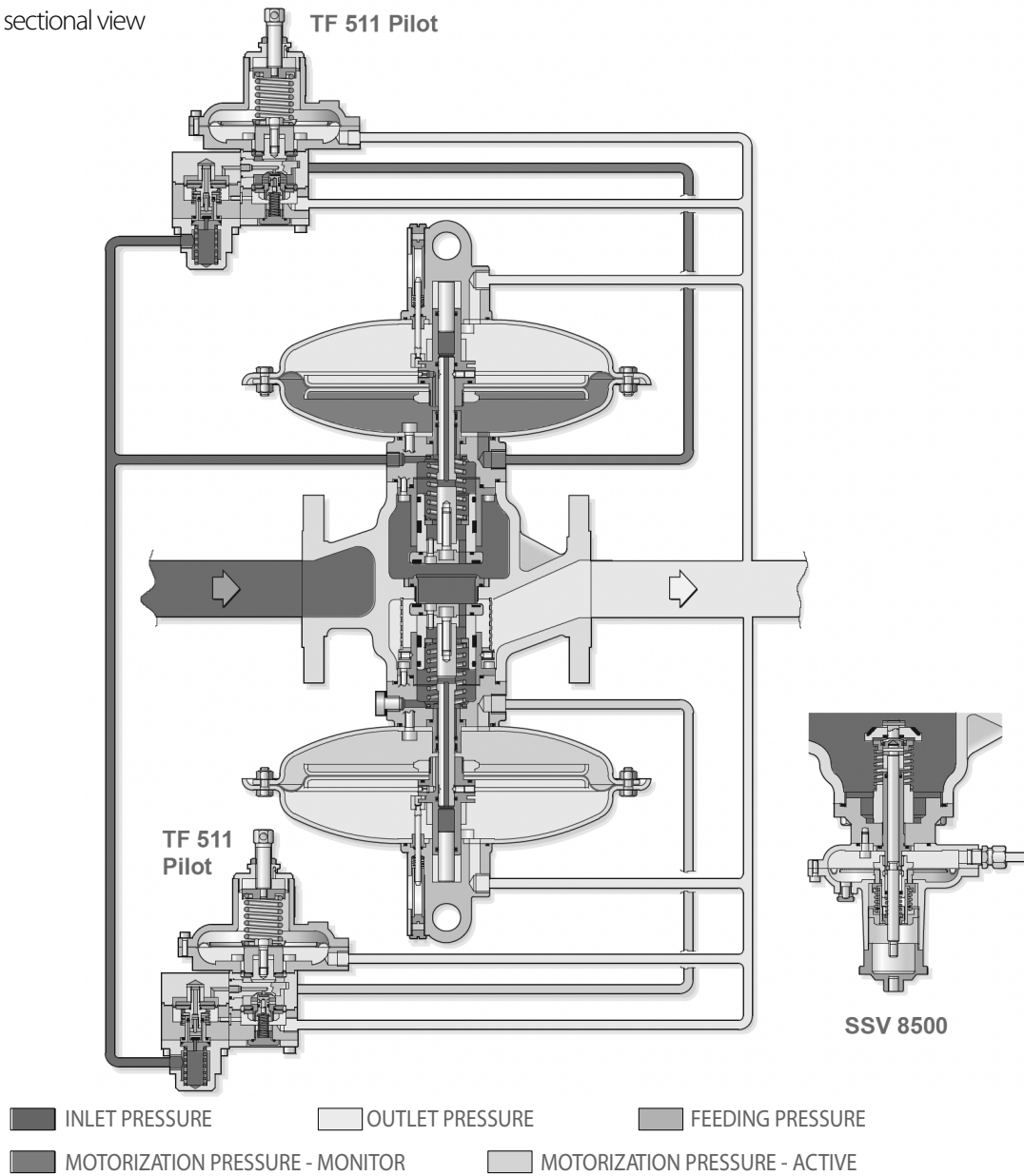

Regulator spring ranges

Pilot Type	Spring Code	Spring Characteristics				Spring Range	
		D mm	De mm	Lo mm	It mm	mbar	bar
TF 511	20565125	2.5	35	50	6	5 - 25	
TF 511	20565126	3	35	50	6	20 - 68	
TF 511	20565127	3.5	35	50	6	40 - 140	
TF 511	20565128	4	35	50	6	80 - 280	
TF 512	20565128	4	35	50	6		0.1 - 0.6
TF 512	20565129	4.5	35	50	6		0.2 - 1.0
TF 513	20565132	3.5	35	60	6.5		0.3 - 1.3
TF 513	20565133	4	35	60	6.5		0.5 - 2.5
TF 513	20565131	5	35	60	6.5		1.5 - 5.5
TF 513	20565134	6	35	60	6.5		4.0 - 13

Spring characteristics:

d : wire diameter
 De: external diameter
 Lo: height
 It: nber of spire

Installation

- Check that the maximum inlet pressure is not higher than the design pressure of the regulator.
- Regulator should be lifted only with belts around the body.
- Arrange enough room for the serving of the regulator.

Before installing the pressure regulator in the piping, the following must be checked:

- the upstream and downstream flanges must be parallel so as to install the regulator without undue stress.
- the upstream piping must be cleaned from all impurities (sand, welding slag, etc.)
- the pressure regulator must not be visibly damaged.
- the inlet and outlet chambers of the pressure regulator must be perfectly clean.

Make sure that the direction of gas flow corresponds to the arrow on the pressure regulator body.

When tightening the flange bolts, the following maximum torque - applicable to Class 5.6 bolts should not be exceeded:

M12	M14	M16	M20
35 Nm	55 Nm	85 Nm	170 Nm

For ease of operation, we recommend performing installation with the valve body in horizontal alignment, with actuator upwards.

Installation with actuator downwards or vertical installation are also possible.

Fig 3 gives a typical example of installation:

- The downstream vent valve eases start-up and changes in pressure setting
- The creep relief valve - optional - limits pressure surges (example: gas thermal expansion in case of downstream piping exposed to sun radiation at zero flow).

Outlet buffer volume

In case of fast variations of gas demand (ON/OFF), the response time of the regulator may cause transient pressure surges or drops that may trigger the overpressure or under-pressure protection devices. These pressure changes can be limited to acceptable values by providing for a enough downstream piping volume.

Sensing line

The sensing line must be connected to a section reasonably free from turbulences, preferably in a straight section of the downstream piping as shown in Fig 3. Outlet pipe dimensions shall be such that the gas velocity at pressure sensing tap does not exceed those given below:

- Outlet pressure < 200 mbar
15 to 20 m/s
- Outlet pressure > 200 mbar
20 to 40 m/s

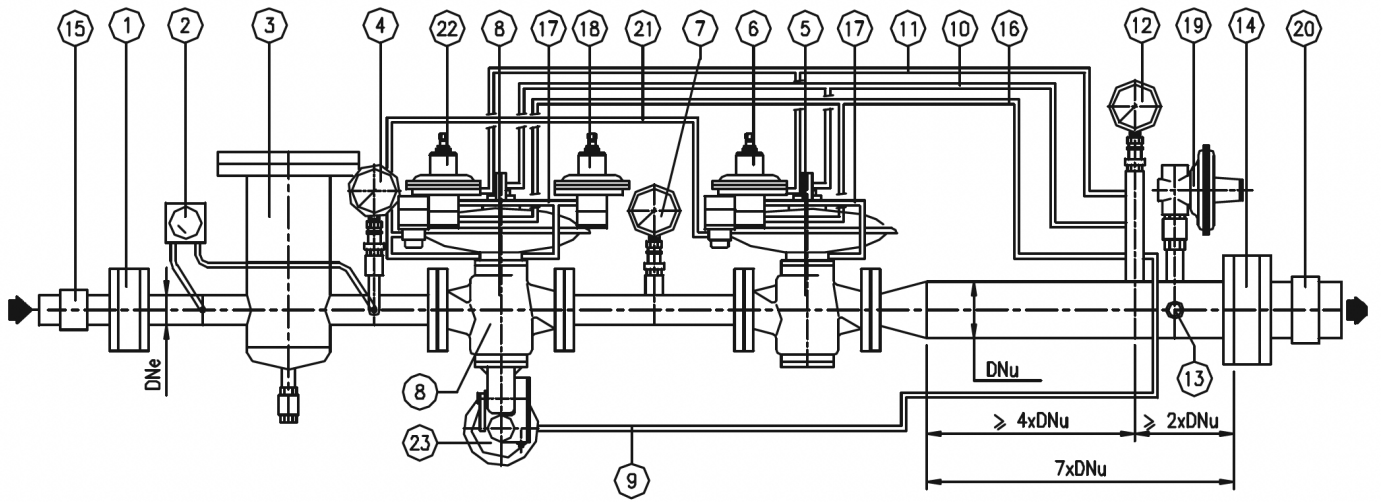
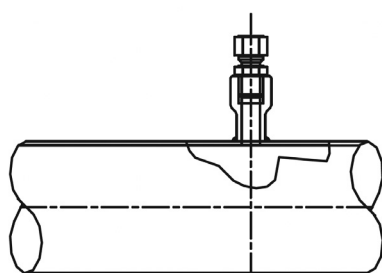

Fig 4 - Typical installation - RB 4700 active regulator, monitor regulator and SSV 8600 shutoff valve
 RB 4600 operates such as illustrated, but inside of one common body

Pipework should be made to prevent impurities and condensates from collecting and obstructing the passage of the gas.

Pipework slope upwards from the pressure tap is recommended - see Fig 5.



Installation with safety systems

SSV

The SSV must have a dedicated sensing line, whose point of sensing provides a representative pressure. An isolating valve on the sensing line is not permitted.

Monitor

The RB 4600 regulator includes 2 separate control systems built onto a single valve body. Both sensing lines shall be piped downstream, as shown in the Fig 4.

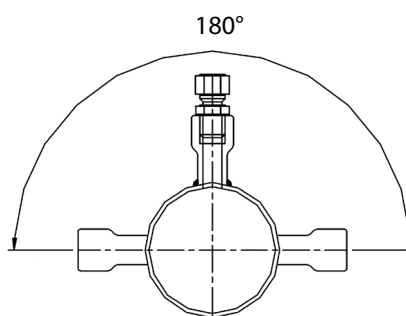

REMARKS FOR USE IN POTENTIALLY EXPLOSIVE ATMOSPHERES (ATEX):

- If film of rust is possible (flying rust in the immediate product surroundings), all outer aluminium parts have to be protected accordingly (e.g. by varnish).
 - The product must be electrically connected to adequately earthed installation.
 - For installation, removing or repair of the product on site, only tools allowed for the corresponding explosion area can be used.
- The product shall not be exposed to: flames, ionised radiation and ultrasound.
 - Ambient temp. conditions must be considered, including possible additional heating effects due to other devices in immediate vicinity.
 - Gas pressure regulator according to DIN EN 334 - if not equipped, with any electronic device - do not have a potential ignition source and therefore are not in the scope of European directive 2014/23/EU.

Regulator Start-up

After the pressure regulator has been installed, make sure that the on/off valve upstream and downstream and the vent valve are all closed.

- partially open the upstream on/off valve slowly enough to pass a very small amount of gas;
- reset the safety shutoff valve (see the relevant Instruction Manual). Note that a safety shutoff valve with over and under-pressure protection is always closed in absence of gas downstream from the regulator, where its sensing line is connected.
- check that the pressure rises slowly; the downstream pressure must stabilize around the set value. If the pressure continues to rise, interrupt the starting procedure by closing the upstream on/off valve and identify the cause of the malfunction;
- after the outlet pressure has stabilized, open the on/off valve completely;
- then slowly open the downstream on/off valve until the piping is completely filled.

At this point, the pressure regulator is operative.

Monitor Start-up

The same procedure must be followed when starting a monitor and active system, bearing in mind that the pressure gauge installed in the section in between the two regulators must indicate the same pressure value as the upstream gauge.

Pressure Regulator Setting

The pressure regulator is usually delivered already set to the specifications indicated in the order sheet. Whenever the set pressure must be modified, this value must be set within the setting range **Wa** of the spring installed.

Make sure there is a flow demand or open the vent valve downstream of the regulator. This valve should be closed after the desired set pressure is obtained.

- **To increase the set pressure:**
rotate clockwise the adjustment screw on top of the pilot - see Fig 1.
- **To decrease the set pressure:**
proceed as above, rotating the spring adjustment screw counter-clockwise.

Maintenance

The maintenance operations required for the pressure regulator (and the safety shutoff valve) are closely linked to the quality of gas supplied (in terms of moisture content, liquid hydrocarbons and impurities in general) and to the degree of filtration performed upstream of the pressure regulator. For this reason we recommend always installing a **cartridge filter** upstream from the pressure regulator that is capable of withholding the solid and liquid particles present in the gas that might otherwise compromise efficient operation.

All pressure must be discharged before performing any maintenance operation on the pressure regulator by proceeding as follows:

- Close the on/off valves upstream and downstream,
- Slowly discharge the pressure by opening the vent valve downstream from the pressure regulator until the gauge indicates zero.

Before performing any maintenance operation on pressure regulators fitted with **overpressure and underpressure** shutoff devices, open the bypass between the inlet and outlet chambers (see Instruction Manuals for safety shutoff valve). This relieves the pressure that otherwise would be trapped upstream from the valve disc of the safety shutoff device.

Disassembly

- Check the following before beginning any disassembly operations on the pressure regulator:
- The regulator must be depressurized as described above;
- The wrenches and other tools required for the operation must be close at hand;
- Spare parts to replace damaged parts must be immediately available.

Remember to:

- Disassemble all parts carefully in order to avoid damage. Pay extra attention to the rubber parts (using the appropriate tool for the disassembly of the O-rings) and replace all parts that exhibit even the slightest signs of damage.

Built-in safety valve

Thanks to its modular design, the retrofit - or change of safety valve model - can be easily made on the field without dismounting the regulator from the gas line.

Frequency of the minimum substitution according to the maintenance interval for all the soft parts, including O-rings, membranes, diaphragms, as well as for the metallics parts more used like valve seat, filters, stems – maintenance sparepart kits are available for regulators.

P inlet	Flow Capacity				
	Qnom >1200kW			Qnom <1200kW	
Bar	Inspection	Functional checks	Maintenance	Functional checks	Maintenance
0,04<P<0,5	1 every 2 years	1 every 2 years	ever 8 years	every 3 years	based on needs
0,5<P<5	1 per year	1 per year	every 7 years	every 2 years	
5<P<12	1 per year	1 per year	every 5 years	1 per year	

Tools

This table indicates the tool relevant for the various parts as shown by position number (see Sectional views)

Tool Type	Nominal tool size	Regulator Size				Pilot
		DN25	DN40 DN50	DN80	DN100	
A	2	35				
	3	14-24-35	14-24	14 - 35	14 - 35	
	4	48	48	48	48	311
	5			24	24	314-319-333-340
	6	17 - 51	17-29-51	51	51	
	8			17 - 29	17 - 29	
B	13	13	13	13	13	
	30					
C	9					326
	10					
	13	11-20-403	11	11	11	306 - 317
	14					301
	17		20 - 403			
	19	21	21	21		
	22	39	39	20-39-403		
	30					
	50	16 - 52	16 - 52	16 - 52		

Recommended tools

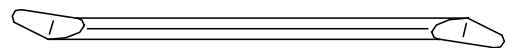
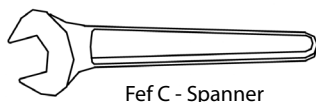
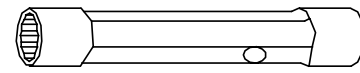
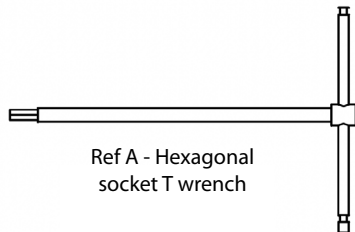

WARNING Read before you start

It is imperative that all maintenance procedures be conducted exclusively by duly qualified personnel. Should the necessity arise, it is recommended to contact our technical support representatives or our authorized dealers.

It is important to note that the regulator and its associated pressure components are susceptible to the effects of normal wear and tear. Therefore, it is essential to conduct regular inspections and, when necessary, replace these components to ensure optimal performance and safety.

The frequency of inspection, examination, and replacement is contingent upon the severity of the service conditions and in accordance with the relevant national or industry codes, standards, and regulations/recommendations.

In accordance with applicable national or industry codes, standards, and regulations/recommendations, all hazards covered by specific tests after final assembly before applying the CE marking shall be covered also after every subsequent reassembly at the installation site. This is done to ensure that the equipment will be safe throughout its intended life.

Prior to commencing any maintenance procedures, it is imperative to shut off the gas supply at both the upstream and downstream points from the regulator. Furthermore, it is essential to ascertain that there is no residual gas pressure within the regulator body itself by loosening the upstream and downstream connections. Upon completion of the aforementioned steps, it is then necessary to conduct a visual inspection for any potential leaks using a soap solution.

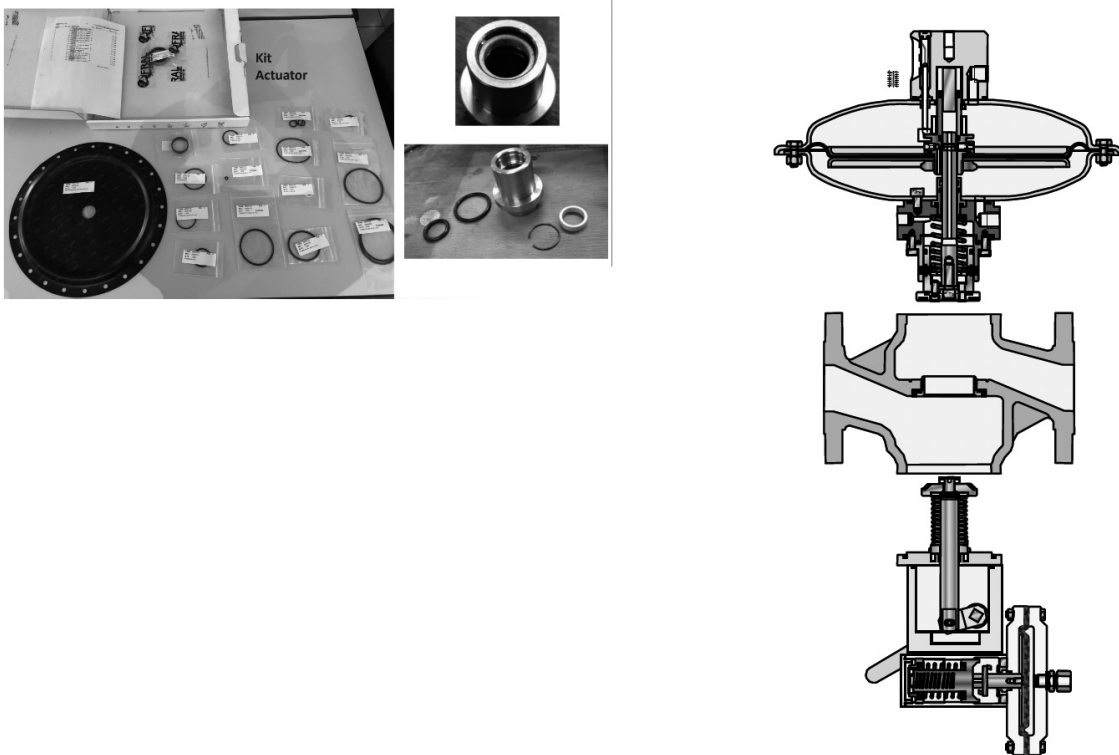

Maintenance of the actuator body

- Disconnect piping of Pilot and SSV and Sensing lines
- Remove Pilot with 2 screws from the actuator top part
- Remove all other remaining screws to open the actuator top part
- Remove the position indicator and replace the wear parts #1+2
- Remove the grub screws on the valve rod guide and replace the wear parts #3+4+5
- Dismount the membrane assembly and replace the membrane #6
- Dismount the lower part of the actuator with 6 screws and replace the wear part #7
- Replace the wear parts #8+9+10
- Carefully dismount the adapter with the 4 screws off the valve body; the spring will push the adaptor open
- Replace the wear parts #11-13
- Dismount the valve plate with 3 screws
- Replace the wear parts #14-16

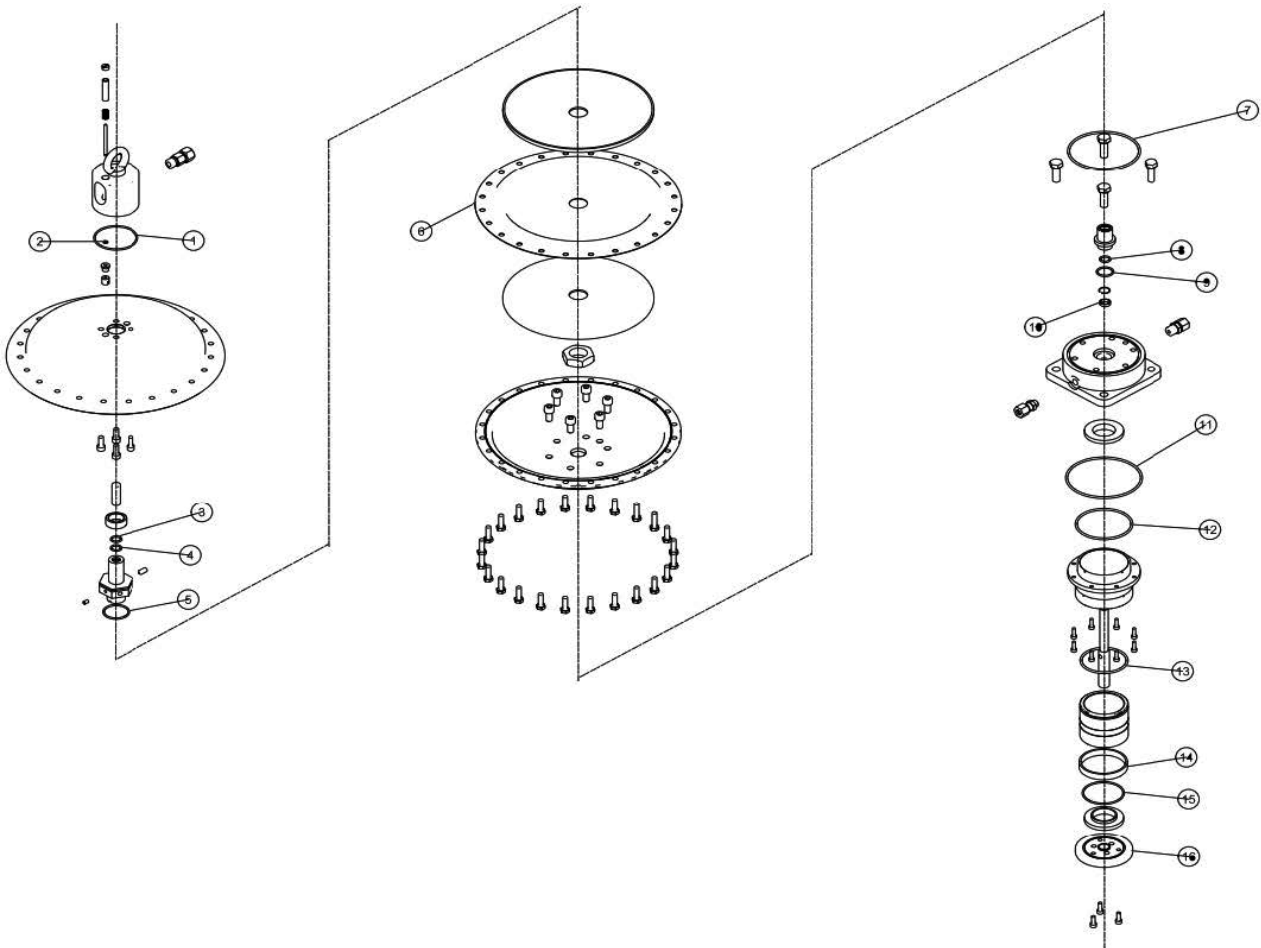

RB47xx Actuator

Maintenance of the SSV body

- First open spring cap and unwind the adjusting spring
- Open the lid of the transmission, replace the wear part #82
- Dismount the transmission and replace wear parts #36+38
- Open the actuator with the 6 screws and replace the membrane #15
- Relax the spring by locking the release lever
- Dismount the SSV with the 4 screws from the valve body
- Tense the spring by locking the release lever in the opposite position
- Beat out the pin #54 of the valve plate with a pin punch and hammer
- Replace the valve plate #53
- Dismount the cover plate with 4 screws
- Dismount the deflection rod and replace the wear parts #53+91
- Dismount the release lever and replace the wear parts #36+38

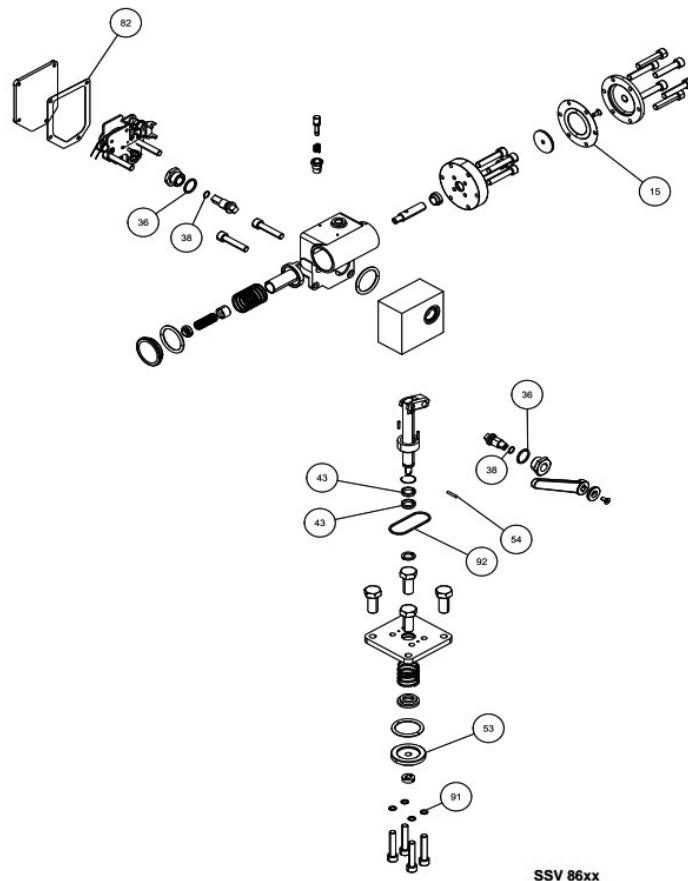

Maintenance of the regulator body

- After the actuator and SSV are dismantled, the wear parts #17+18 can be replaced

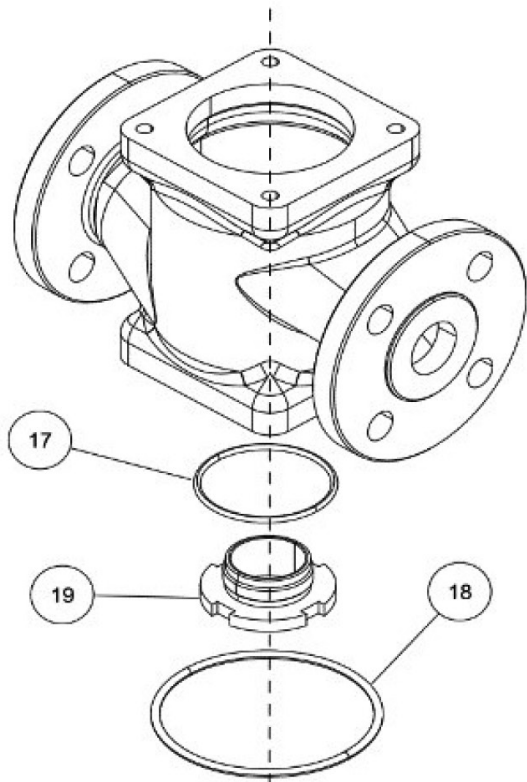

Maintenance of the Pilot

- Disconnect the pre-stage from the pilot with 4x long screws and replace the wear parts
- #9+16
- Disconnect the 2 blocks of the pre-stage with the 4x screws on both sides
- Replace wear parts #3+13+1+8+10+14+11+2
- First open spring cap and unwind the adjusting spring and replace the wear part #18
- Dismount the top part of the actuator with 4/12 (depending on pilot type) screws
- Open the screw nut on top of the valve rod
- Replace the membrane #4 and the ring#17
- Dismount the lower part of the actuator with 4 screws
- Replace the membrane #6
- Dismount the block with 4 screws
- Replace the wear parts #19+5+12+7+15

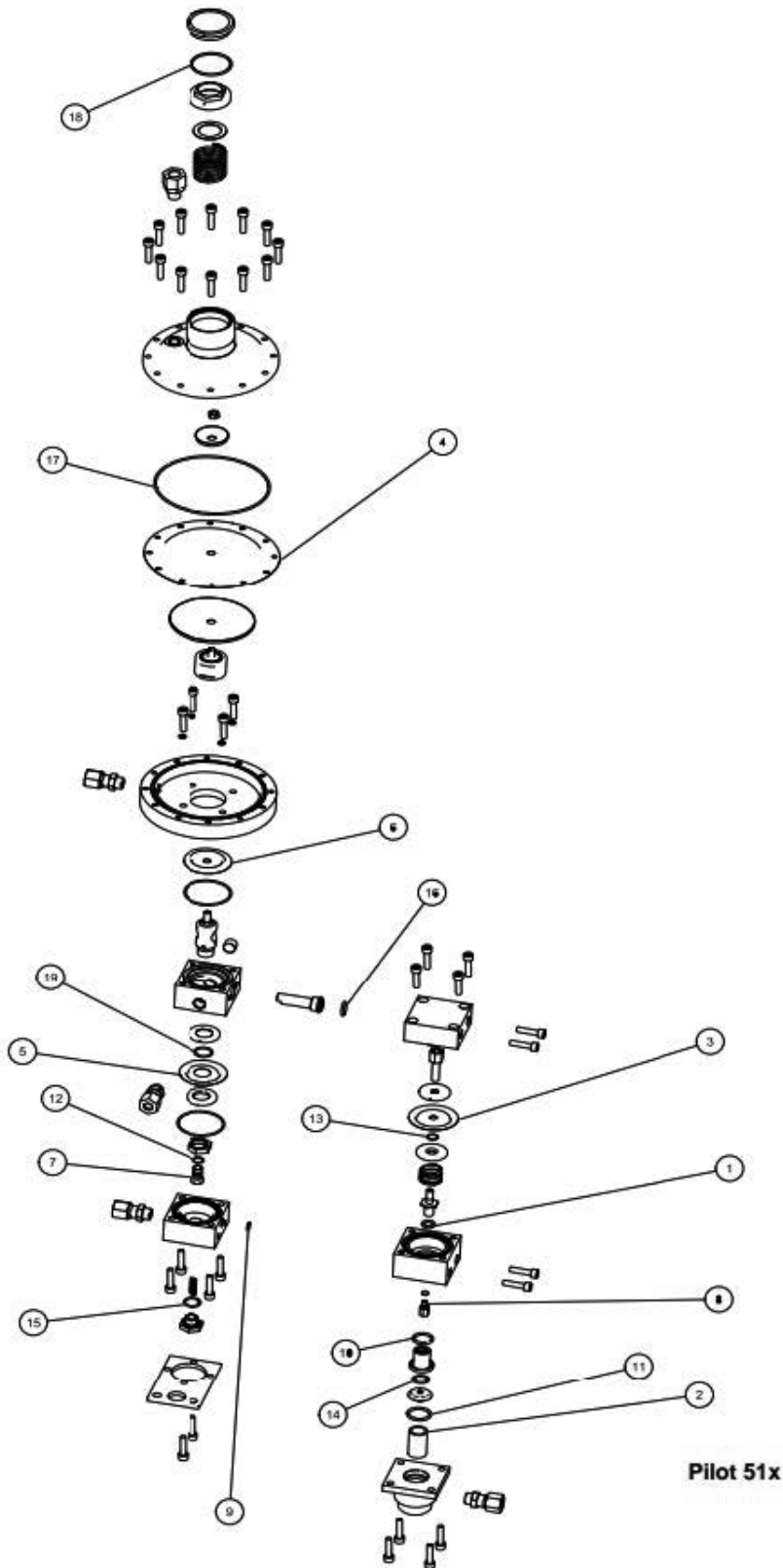

Dresser Utility Solutions GmbH

Hardeckstr. 2
 76185 Karlsruhe
 T: +49 (0)721 / 5981 - 100
 info.karlsruhe@dresserutility.com



© 2024 Dresser Utility Solutions GmbH – All rights reserved. Dresser Utility Solutions reserves the right to make changes in specifications and features shown herein, or discontinue the product described at any time without notice or obligation. Contact your Dresser Utility Solutions representative for the most current information. The Dresser Logo and all Trademarks containing the term "Dresser" are the property of Dresser, LLC, a subsidiary of Baker Hughes. Actaris™ is a trademark owned by Itron, Inc. and used under license.

3400992805 AGR RB 4600 Instruction Manual DUS.AGR.EN.AE

10.24