

# RB 1700 - 3/4"

## Commercial & Industrial Regulator

The RB 1700 regulator is designed for commercial applications, appliance pressure regulation, secondary regulation of plant distribution piping, and all installations with continuous consumption and rapid flow rate variations, such as burners, industrial ovens, boilers, etc.



### Description

The RB 1700 model is a direct-acting, spring-loaded regulator with an optional built-in safety shut-off device. Its balanced valve design ensures constant outlet pressure when the upstream pressure varies. An optional built-in shut-off valve offers protection against over-pressure and over-and under-pressure. Its bypass system eases the shut-off valve relatching.

### Technical Features

<b>Inlet pressure</b>	19 bar
<b>Outlet pressure</b>	0.1 bar - 4.8 bar
<b>Accuracy &amp; lock-up pressure</b>	Up to AC 10 / up to SG 20
<b>Operating temperature</b>	-20°C to +60°C
<b>Ambient temperature</b>	-30°C to +60°C (body material)
<b>Acceptable gases</b>	Natural gas, town gas, propane, butane, air, nitrogen or any non-corrosive gas
<b>Safety devices</b>	Optional built-in safety shut-off valve: over-pressure shut-off (OPSO) and under-pressure shut-off (UPS0)

### Sizes & Connections

<b>Body sizes</b>	3/4"
<b>Outlet pressure</b>	Parallel internal thread according to ISO 7-1, ISO 228-1 or NPT

### Materials

<b>Body</b>	Spheroidal graphite cast iron EN 1563 grade EN-GJS-400-15
<b>Head</b>	Pressed steel UNI EN 10025
<b>Internal parts</b>	Stainless steel and brass
<b>Seals</b>	Nitrile rubber
<b>Diaphragm</b>	Synthetic rubber with fabric reinforcement

### Key Benefits

- » High flow accuracy
- » Easy maintenance
- » Rugged construction for durability
- » Balanced valve design eliminates inlet pressure effect
- » EN 334 compliant

### Operational Diagram

Accuracy class (AC), lock-up pressure class (SG) and lock-up pressure zone:

- » RB 172x 0.1 - 0.4 bar AC 20 / SG 30
- » RB 172x 0.4 - 1.3 bar AC 10 / SG 20
- » RB 173x 0.5 - 2.5 bar AC 10 / SG 20

The typical lock-up pressure zone is:

$$\frac{Q_{min, Pu}}{Q_{max, Pu}} = \frac{2.5}{100}$$

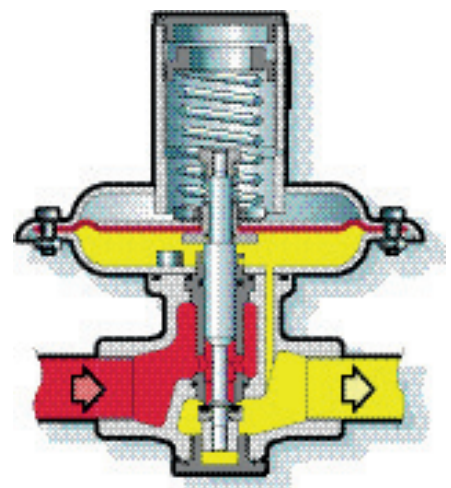

■ Inlet Pressure ■ Outlet Pressure

### Operational Diagram

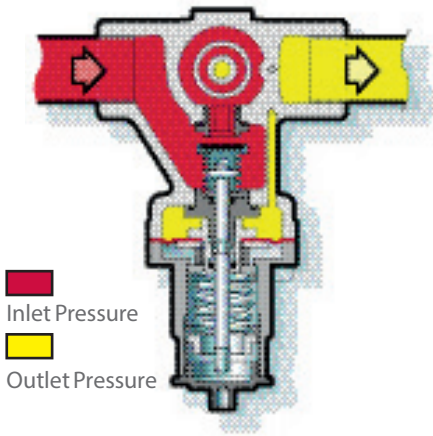

#### Standard conditions:

- » Absolute pressure of 1.013 bar
- » Temperature of 15°C

#### Spring characteristics:

d: wire diameter      Lo: height  
De: external diameter      Lt: no. of spires

#### Correction factor for non-natural gas applications:

The flow rates are indicated for a 0.6 specific gravity gas.

To determine the volumetric flow rate for gases other than natural gas, multiply or calculate the values in the capacity tables using the sizing equations with a correction factor.

The table below lists correction factors for some common gases:

Gas type	Specific gravity	Correction factor
Air	1.00	0.77
Butane	2.01	0.55
Carbon dioxide (dry)	1.52	0.63
Carbon monoxide (dry)	0.97	1.00
Natural gas	0.60	1.00
Nitrogen	0.97	0.79
Propane	1.53	0.63
Propane-Air mix	1.20	0.71
Natural Gas +20% H2	0.50	1.10

Specific gravity or relative density (air = 1, non-dimensional value)

Use the following formula to calculate the correction factor for gases not listed above. In the formula, d is the specific gravity of the gas.

$$\text{Correction factor} = \sqrt{\frac{0.6}{d}}$$

## SAFETY SHUT-OFF VALVE

The RB 1700 Series regulators can be fitted with a safety shut-off valve for over-pressure (OPSO) or combined under-and over-pressure (UPSO/OPSO) protection. The SSV trip pressure can easily be adjusted independently of the regulator set point. The closing plug of the SSV controller is used as a pulling tool to relatch the valve.

A built-in bypass, for balancing pressure before relatching the safety shut-off valve, is operated by pulling the valve stem.

#### Accuracy class (AG)

» 0.3 - 5.7 bar AG 10

#### Minimum difference between regulator and SSV settings (ΔPw):

» 15%, of set point

## Outlet Pressure Range

### Regulator 3/4"

Spring Code	Spring Characteristic				Spring Range	
	d (mm)	De (mm)	Lo (mm)	Lt	1720 - 1721 - 1722 (Ø165)	1730 - 1731 - 1732 (Ø90)
20565141	3.5	35	80	8	0.12 - 0.40 bar	•
20565142	4	35	80	8	0.21 - 0.65 bar	•
20565143	4.5	35	80	8	0.34 - 0.92 bar	•
20565144	5	35	80	8	0.55 - 1.32 bar	•
20565127	3.5	35	50	6	•	0.50 - 0.85 bar
20565128	4	35	50	6	•	0.80 - 1.30 bar
20565129	4.5	35	50	6	•	1.20 - 2.30 bar
20565130	4.5	35	60	6.5	•	2.00 - 3.30 bar
20565131	5	35	60	6.5	•	2.00 - 4.80 bar

## Safety Shut-off Valve

### Over Pressure Shut-off Springs (OPSO)

Spring Code	Spring Characteristic				Spring Range	
	d (mm)	De (mm)	Lo (mm)	Lt	1721 - 1722 - 1731 - 1732 (Ø60)	
20563124	2.2	25	35	5.5	0.30 - 0.60 bar	
20563121	2.5	25	35	5	0.50 - 1.10 bar	
20563115	3	25	35	5.5	1.10 - 2.10 bar	
20563116	3.5	25	35	5.5	2.00 - 4.00 bar	
20563119	3.8	25	36.5	5.5	4.00 - 5.70 bar	

### Under-Pressure Shut-off Springs (UPSO)

20560516	1	10	30	5.5	0.10 - 0.22 bar
20560517	1.2	10	30	5	0.22 - 0.45 bar

## Flow Capacity

The following table gives the maximum flow capacity - in m<sup>3</sup>/h at standard conditions. More data are available in the leaflet "RB 1700 Capacity Tables".

Inlet Pressure	Inlet Pressure					
	RB 1720 150 mbar	RB 1720 300 mbar	RB 1720 500 mbar	RB 1720 0.8 bar	RB 1720 2 bar	RB 1720 4 bar
250 mbar	9	•	•	•	•	•
500 mbar	17	16	•	•	•	•
700 mbar	20	22	19	•	•	•
1 bar	26	30	30	10	•	•
1.5 bar	32	38	44	20	•	•
3 bar	50	60	70	36	34	•
5 bar	50	70	100	50	60	60
7 bar	50	70	140	70	80	100
≥ 10 bar	50	70	170	95	110	140

In order to limit the noise emission it is recommended not to exceed a gas velocity of 100 m/s at the regulator outlet.

## Flow Capacity

For a 0.6 specific gravity gas, the wide-open orifice flow (Q) may be calculated using the following equations:

- » Sub-critical flow behaviour:  $Q = KG \sqrt{P_u(P_u - P_d)}$  where  $(P_u - P_d) \leq 0.5 P_u$
- » Critical flow behaviour:  $Q = KG P_u / 2$  where  $(P_u - P_d) > 0.5 P_u$

### Wide-open Flow Coefficient KG

90 (without safety shut-off valve)

## Overall Dimensions

DN	Actuator	A mm	B mm	C mm	D mm	E mm	F mm	G mm	Weight (kg)	
										with SSV
3/4"	Ø 165	100	185	32	165	130	60	46	3.0	4.0
3/4"	Ø 90	100	175	32	90	130	60	46	2.2	3.2

### Vent and Sensing Lines

- » Regulator sensing line: internal
- » Regulator vent line: G 1/2" as option
- » SSV sensing line: internal
- » SSV vent line: Rp 1/8

## Type Designation

RBI 17	X	X	- DN	X	Options
	2				Medium pressure
	3				High pressure
		0			No safety device
		1			Over-pressure shut-off valve
		2			Over-and under-pressure shut-off valve
				3/4"	Body size

### where:

Q = volumetric flow rate in m<sup>3</sup>/h at standard conditions

P<sub>u</sub> = absolute inlet pressure in bar

P<sub>d</sub> = absolute outlet pressure in bar

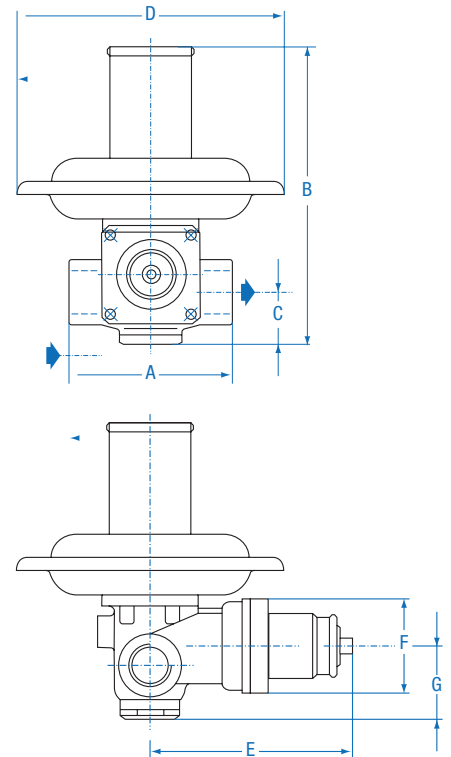

RB 1700 DN 3/4" Gas

### Information to be specified when ordering:

- » Regulator type code
- » Minimum and maximum inlet pressures
- » Outlet pressure range setting
- » Outlet pressure setting
- » Connection type
  - OPSO setting\*
  - UPSO setting\*

\* (if requested)

**Dresser Utility Solutions GmbH**

Hardeckstr. 2  
76185 Karlsruhe  
T: +49 (0)721 / 5981 - 100  
info.karlsruhe@dresserutility.com



*© 2024 Dresser Utility Solutions GmbH – All rights reserved. Dresser Utility Solutions reserves the right to make changes in specifications and features shown herein, or discontinue the product described at any time without notice or obligation. Contact your Dresser Utility Solutions representative for the most current information. The Dresser Logo and all Trademarks containing the term "Dresser" are the property of Dresser, LLC, a subsidiary of Baker Hughes. Actaris™ is a trademark owned by Itron, Inc. and used under license.*