

SRV 801 / 811

Safety Relief Valves

The 801 and 811 relief valves are installed downstream of pressure regulators to relieve limited volumes of gas. Used where venting to the atmosphere is acceptable, they provide cost-effective solutions to prevent safety shut-off valves from triggering in case of thermal expansion, transient pressure surges, and creep leaks from regulators. These valves are ideal for low pressure settings due to the increased sensitivity provided by a large diaphragm area.

DESCRIPTION

The 801 and 811 relief valves are spring-loaded throttling relief valves, where a diaphragm measures the system (inlet) pressure, a spring provides the initial load to the diaphragm and establishes the relief set point, and a valve throttles the relief flow.



KEY BENEFITS

- » Compact design
- » Accurate operation
- » High flow capacity
- Reliable
- » Tight shut-off

Technical Specifications

Relief set pressure range	8 - 700 mbar
Operating temperature	-20°C to +60°C
Acceptable gases	Natural gas, town gas, propane, butane, air, nitrogen or any non-corrosive gas

Sizes & Connections

Sizes	DN 1"
Type	Gas female threaded

Materials

Body-Casing-Cover	Aluminium
Valve	Nitrile Rubber
Diaphragm	Rubber, fabric reinforced
Internal Parts	Brass and Stainless Steel

Flow Capacity

Relief Set Pressure (mbar)	Buildup Over Relief Pressure Setting (mbar)	Capacity at Standard Conditions (m3/h)
35	3.5	18.5
35	7	29
64	6.5	22
64	13	38

Standard conditions:

- Absolute pressure of 1.013 bar
- Temperature of 15°C

The flow rates are indicated for a 0.6 specific gravity gas

SRV Spring Selection Tables - DN 1"

SRV	Spring Code	Spring Characteristic				Wu (mbar)
		d	De	Lo	Lt	
801	20563325	1.3	25	55	8	15 ÷ 30
	20563025	1.5	25	50	6.5	28 ÷ 70
	20563026	1.7	25	50	7	40 ÷ 85
	20563027	1.9	25	50	6.75	55 ÷ 120
	20563028	2.2	25	50	7.5	75 ÷ 240
811	20564141	1.6	30	80	9.5	8 ÷ 18
	20564142	1.8	30	80	9	16 ÷ 28
	20564044	2.2	30	80	9	30 ÷ 56
	20564042	2.5	30	80	9	40 ÷ 90
	20564143	3	30	80	9	90 ÷ 190
811/TR	20564042	2.5	30	80	9	100 ÷ 230
	20564143	3	30	80	9	210 ÷ 450
	20564144	3.5	30	80	9	420 ÷ 700

Spring characteristics:

- d: wire diameter
- Lo: height
- De: external diameter
- Lt: no. of spires

Overall Dimensions (mm)

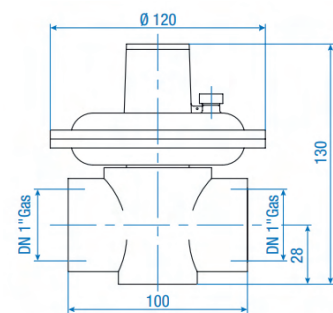

Type SRV 801 / Weight 0.8 kg

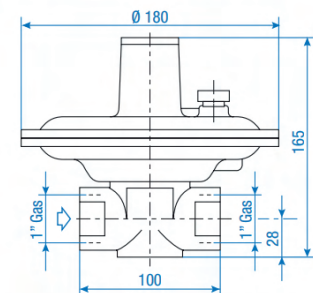

Type SRV 811 / Weight 1.2 kg

Note: Accuracy at the initial leak point, at which the relief valve begins to discharge, is in the range of $\pm 5\%$ of the setting.

OPTIONS

SRV 811 may be fitted with a pressure tap (Ermeto 8 coupling) for system (inlet) pressure indicator - Code: SRV 811/I or SRV 811/I/TR.

SRV 811 may be fitted with a valve disk down-stream to the flow, which reduces the popping effect and allows a smooth throttling of the flow - Code: SRV 811/A or SRV 811/A/TR.

Information to be specified when ordering:

- » Model
- » Inlet pressure
- » Relief pressure range
- » Connection type
- » Maximum flow rate
- » Kind of gas
- » Quantity required

Dresser Utility Solutions GmbH

Hardeckstr. 2
76185 Karlsruhe
T: +49 (0)721 / 5981 - 0
info.karlsruhe@dresserutility.com

DRESSER
UTILITY SOLUTIONS
www.dresserutility.com

© 2025 Dresser Utility Solutions GmbH – All rights reserved. Dresser Utility Solutions reserves the right to make changes in specifications and features shown herein, or discontinue the product described at any time without notice or obligation. Contact your Dresser Utility Solutions representative for the most current information. The Dresser Logo and all Trademarks containing the term "Dresser" are the property of Dresser, LLC, a subsidiary of Baker Hughes. Actaris™ is a trademark owned by Itron, Inc. and used under license.