

RB 4700

Commercial & Industrial Regulator

The RB 4700 regulator is designed for use in industrial and distribution applications such as district station and heating plants, and for industrial customers.

Description

The RB 4700 is a pilot-operated regulator with an optional integrated safety shut-off device.

Its pilot system provides a fast and accurate response to flow rate variation.

Pilot supply is protected by a separate fine filter. An automatically loaded pressure feeder allows accurate control at high inlet pressure.

The optional built-in shut-off valve offers protection against over-pressure or over- and under-pressure. Its bypass system makes it easy to relatch the shut-off valve.

Technical Features

Inlet pressure	25 bar
Outlet pressure	5 mbar – 13 bar
Differential pressure	0.3 bar mini
Accuracy	Up to AC1 / SG 2,5
Operating temperature	-20°C to +60°C
Ambient temperature	-30°C to +60°C
Acceptable gases	Natural gas, town gas, propane, butane, air, nitrogen or any non-corrosive gas
Safety devices	Optional built-in safety shut-off valve: Over-pressure shut-off (OPSO) and under-pressure shut-off (UPSO)
Options	Noise reduction Travel stop (DN 25 only)

Sizes & Connections

Sizes	DN 25, DN 40, DN 50, DN80, DN100
Body lengths	EN 334 face-to-face recommended dimensions (PN 16 - 25; PN 50)
Body rating	PN16, PN20, PN25, ANSI CL150, 300

Materials

Body	Spheroidal graphite cast iron EN 1563 grade EN-GJS-400-18 Steel: EN 10213-3 grade G20 MN5
Head	Pressed steel / UNI EN10025
Internal parts & Pilot	Steel, stainless steel, brass and aluminium
Seals	Nitrile rubber
Diaphragm	Synthetic rubber with fabric reinforcement



Key Benefits

- » High flow capacity
- » Accurate control
- » Low differential
- » Easy maintenance
- » Rugged construction for durability
- » Low noise
- » Travel indicator
- » Approved by the major European gas distribution companies

Operational Diagram

Accuracy class (AC), lock-up pressure class (SG) and lock-up pressure zone:

- » 10 - 100 mbar : AC 2.5 / SG 5
- » 100 mbar : AC 1 / SG 2.5

The typical lock-up pressure zone is:

$$\frac{Q_{min, Pu}}{Q_{max, Pu}} = \frac{2.5}{100}$$

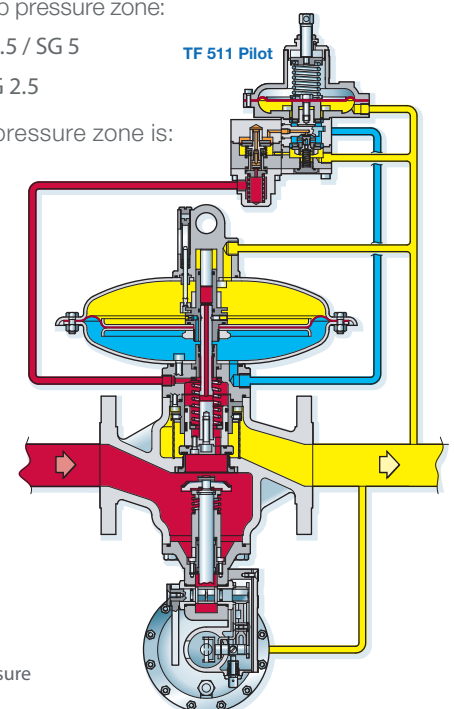
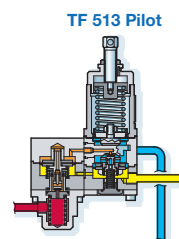

- Inlet Pressure
- Outlet Pressure
- Feeding Pressure
- Motorization Pressure

Pilot System

RB 4700 regulators are equipped with a TF 500 series pilot system, as follows:

TF 5	1	X	Options
		1	Low pressure: 5 - 280 mbar
		2	Medium pressure: 0.1 - 1 bar
		3	High pressure: 0.25 - 13 bar

Outlet Pressure Range

Pilot Type	Spring Code	Spring Characteristic				Spring Range	
		d (mm)	De (mm)	Lo (mm)	Lt	mbar	bar
TF 511	20565125	2.5	35	50	6	5 - 25	
TF 511	20565126	3	35	50	6	20 - 68	
TF 511	20565127	3.5	35	50	6	40 - 140	
TF 511	20565128	4	35	50	6	80 - 280	
TF 512	20565128	4	35	50	6		0,1 - 0,6
TF 512	20565129	4,5	35	50	6		0,2 - 1
TF 513	20565132	3,5	35	60	6,5		0,25 - 1,3
TF 513	20565133	4	35	60	6,5		0,5 - 2,5
TF 513	20565131	5	35	60	6,5		1,5 - 5,5
TF 513	20565134	6	35	60	6,5		4 - 13

The TF 500 series pilot system includes a built-in pre-regulator which is loaded by the outlet pressure to provide the pilot with a feeding pressure 500 mbar above outlet pressure.

The pre-regulator is fitted with a separate filter.

Flow Capacity

Sizing Equation

For a 0.6 specific gravity gas, the wide-open orifice flow (Q) may be calculated using the following equations:

- » Sub-critical flow behaviour: $Q = K_G \sqrt{P_d (P_u - P_d)}$ where $(P_u - P_d) \leq 0.5 P_u$
- » Critical flow behaviour: $Q = K_G P_u / 2$ where $(P_u - P_d) > 0.5 P_u$

Flow Coefficient K_G

DN	25	40	50	80	100	
K_G	520	1,150	2,050	4,500	8,000	Basic
K_G	490	1,050	1,750	3,700	6,000	With SSV and Silencer
K_i	105	105	105	100	95	

Spring characteristics :

d: wire diameter Lo: height
De: external diameter Lt: no. of spires

Standard conditions :

- Absolute pressure of 1.013 bar
- Temperature of 15°C

Correction factor for non-natural gas applications:

The flow rates are indicated for a 0.6 specific gravity gas.

To determine the volumetric flow rate for gases other than natural gas, multiply or calculate the values in the capacity tables using the sizing equations with a correction factor.

The table below lists correction factors for some common gases:

Gas Type	Specific Gravity	Correction Factor
Air	1.00	0.77
Butane	2.01	0.55
Carbon dioxide (dry)	1.52	0.63
Carbon monoxide (dry)	0.97	0.79
Natural gas	0.60	1.00
Nitrogen	0.97	0.79
Propane	1.53	0.63
Propane-Air mix	1.20	0.71
Natural gas +20% H ₂	0.50	1.10

Specific gravity or relative density (air = 1, non-dimensional value)

Use the following formula to calculate the correction factor for gases not listed above. In the formula, d is the specific gravity of the gas.

$$\text{Correction factor} = \sqrt{\frac{0.6}{d}}$$

Q = volumetric flow rate in m³/h at standard conditions

P_u = absolute inlet pressure in bar

P_d = absolute outlet pressure in bar

Sin = angle in degrees

Operational Diagram

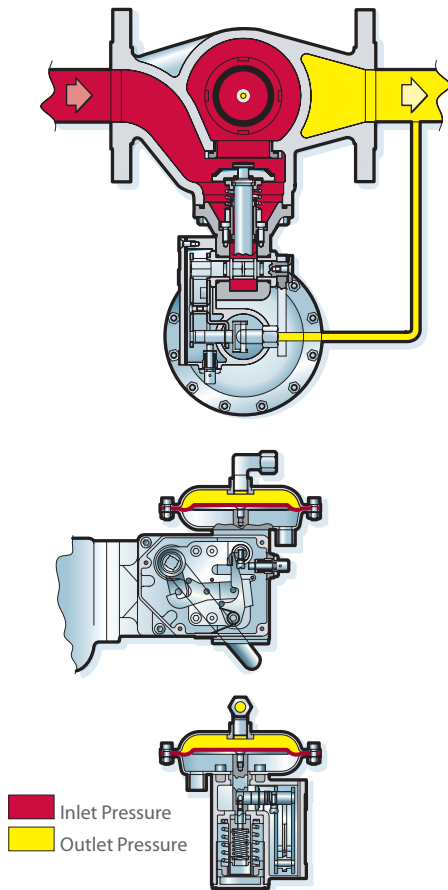

SSV 8600 Safety Shut-Off Valve

Accuracy class (AG)

- » Low pressure: AG 10
- » Medium pressure: AG 2,5
- » High pressure: AG 1

Minimum difference between regulator and SSV settings (ΔP_w):

- » 15%, with a minimum difference of 10 mbar for UPSO and 20 mbar for OPSO.

Type Designation and Options

SSV 86	X	X	Versions
	1		∅ 150
	2		∅ 150/TR
	3		∅ 90
	4		∅ 90/TR
		1	OPSO
		2	OPSO + UPSO

The RB 4700 Series regulators can be fitted with the SSV 8600 safety shut-off valve for overpressure (OPSO) or combined under-and-over pressure (UPSO/OPSO) protection.

The SSV trip pressure can easily be adjusted independently of regulator set point.

The following accessories make the SSV 8600 easier to use:

- » Manual shut-off button for emergency losing
- » Easily accessible lever for relatching the valve
- » Built-in bypass for balancing pressure before relatching the safety shut-off valve. Use the relatching lever to operate the bypass.

Remote control accessories (optional):

- » Valve position indicator (inductive detector or Reed switch)
- » Remote triggering by explosion-proof solenoid valve

Spring characteristics :

d: wire diameter Lo: height
De: external diameter Lt: no. of spires

Set Range

Spring Code	Spring Characteristic				Colour	Spring Range			
	d (mm)	De (mm)	Lo (mm)	Lt		8611/12 (∅ 150)	8621/22 (∅ 150/TR)	8631/8632 (∅ 90)	8641/8642 (∅ 90/TR)
20565233	2,2	35	60	7	Yellow	28 - 65 mbar	•	•	•
20565234	2,5	35	60	7	Red	45 - 100 mbar	•	•	•
20565330	2,7	35	60	7	White	80 - 140 mbar	•	•	•
20565331	3	35	60	7	Blue	100 - 240 mbar	•	0,60 - 0,90 bar	•
20565332	3,5	35	60	7	Orange	190 - 350 mbar	0,55 - 0,90 bar	0,90 - 1,40 bar	•
20565333	4	35	60	7	Brown	350 - 700 mbar	0,90 - 1,70 bar	1,40 - 2,40 bar	2,30 - 4,10 bar
20565334	4,2	35	60	7	Green	450 - 800 mbar	1,50 - 2,00 bar	2,00 - 3,10 bar	3,10 - 5,00 bar
20565430	4,5	35	60	7	Black	600 - 1000 mbar	1,70 - 2,30 bar	2,50 - 3,90 bar	3,80 - 6,00 bar
20565431	5	35	60	7	Grey	950 - 1300 mbar	2,30 - 3,00 bar	3,90 - 4,60 bar	5,70 - 7,50 bar
20565432	5,5	35	60	7	Yellow	•	•	4,60 - 6,30 bar	7,50 - 10,00 bar
20565134	6	35	60	7	Red	•	•	6,30 - 10,80 bar	10,00 - 20,00 bar

Under-Pressure Shut-Off Springs (UPSO)

Spring Code	Spring Characteristic				Colour	Spring Range			
	d (mm)	De (mm)	Lo (mm)	Lt		8611/12 (∅ 150)	8621/22 (∅ 150/TR)	8631/8632 (∅ 90)	8641/8642 (∅ 90/TR)
20561124	1,2	15	40	10	White	5 - 18 mbar	•	•	•
20561221	1,5	15	40	10	Blue	10 - 55 mbar	•	•	•
20561222	1,7	15	40	10	Orange	30 - 75 mbar	0,11 - 0,29 bar	0,23 - 0,37 bar	0,32 - 0,63 bar
20561223	2	15	40	10	Brown	60 - 150 mbar	0,16 - 0,49 bar	0,26 - 0,66 bar	0,42 - 1,10 bar
20561224	2,5	15	40	10	Green	100 - 250 mbar	0,21 - 0,74 bar	0,32 - 1,00 bar	0,60 - 2,20 bar
20561321	2,8	15	35	7	•	•	•	•	2,20 - 5,00 bar min $\Delta p = 1$ bar

SSV 8500 Safety Shut-Off Valve

Minimum difference between regulator and SSV settings (ΔP_w):

- » 10 mbar \leq Pds \leq 30 mbar:
OPSO \geq Pds + 20 mbar
UPSO \leq Pds - 10 mbar
- » 30 mbar < Pds \leq 100 mbar:
OPSO \geq Pds + 20 mbar
UPSO \leq Pds - 20 mbar
- » 100 mbar < Pds \leq 300 mbar:
OPSO \geq Pds + 40 mbar
UPSO \leq Pds - 40 mbar
- » Pds > 300 mbar:
OPSO \geq 120% Pds
UPSO \geq 80% Pds

The RB 4700 Series regulators (*) can be fitted with the SSV 8500 safety shut-off valve for overpressure (OPSO) or combined under-and-over pressure (UPSO/OPSO) protection. The SSV trip pressure can easily be adjusted independently of the regulator set point. The closing plug of the SSV controller is used as pulling tool to relatch the valve. A built-in bypass, for balancing pressure before relatching the safety shut-off valve, is operated by pulling the valve stem.

(*) except for size DN 100.

Operational Diagram

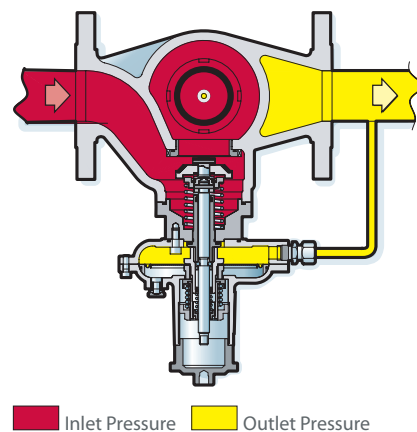

Pds: Set point outlet pressure
OPSO: Over-pressure shut-off
UPSO: Under-pressure shut-off

Type Designation and Options

SSV 85	X	X	Versions
	1		Ø 150
	2		Ø 90
	3		Ø 90/TR
		1	OPSO
		2	OPSO + UPSO

Maximum Inlet Pressure

For higher inlet pressure, the SSV 8500 is fitted with heavier closing spring which gives a positive lock-up even in case of high pressure differential across the valve. The following table indicates the maximum inlet pressure for both options.

DN	25	40	50	80
Standard	6 bar	6 bar	6 bar	6 bar
Heavy duty	16 bar	16 bar	16 bar	6 bar

Set Range

Over Pressure Shut-off Springs (OPSO)

Spring Code	Spring Characteristic				Spring Range		
	d (mm)	De (mm)	Lo (mm)	Lt	8511/12 (Ø 150)	8521/22 (Ø 90)	8531/132 (Ø 90TR)
20565225	2	35	50	6	25 - 49 mbar	0,13 - 0,24 bar	•
20565125	2,5	35	50	6	44 - 120 mbar	0,20 - 0,46 bar	•
20565126	3	35	50	6	95 - 200 mbar	0,42 - 0,90 bar	•
20565127	3,5	35	50	6	200 - 350 mbar	0,83 - 1,84 bar	1,25 - 3,00 bar
20565128	4	35	50	6	•	1,32 - 2,25 bar	2,30 - 4,20 bar
20565129	4,5	35	50	6	•	2,28 - 3,15 bar	3,60 - 5,60 bar

Spring characteristics:

d: wire diameter Lo: height
De: external diameter Lt: no. of spires

Under Pressure Shut-off Springs (UPSO)

Spring Code	Spring Characteristic				Spring Range		
	d (mm)	De (mm)	Lo (mm)	Lt	8511/12 (Ø 150)	8521/22 (Ø 90)	8531/132 (Ø 90TR)
20561022	1,2	15	35	7,75	9 - 19 mbar	0,06 - 0,10 bar	•
20560815	1,3	15	35	8	14 - 30 mbar	0,10 - 0,25 bar	0,15 - 0,40 bar
20561023	1,5	15	35	7,75	28 - 60 mbar	0,10 - 0,33 bar	0,30 - 0,60 bar
20561024	1,8	15	35	7,5	60 - 100 mbar	0,30 - 0,70 bar	0,58 - 1,25 bar
20561121	2	15	35	7,25	•	0,60 - 1,10 bar	1,20 - 1,70 bar
20561122	2,5	15	35	7,25	•	•	1,08 - 2,50 bar

Regulator - Overall Dimensions (mm)

DN	Actuator	A		B	C	D	P	Weight (kg)	
		PN 16/20/25 ANSI 150	PN 50 ANSI 300					PN 16/20/25 ANSI 150	PN 50 ANSI 300
25		184	197	345	70	360	270	23	26
40		222		365	90	360	270	29	
50		254	267	375	100	360	270	32	36
80	with TF 511	298	317	440	130	480	330	62	68
	with TF 512 or TF 513					360	270		
100		352	368	462	140	480	330	87	94

Vent and Sensing Lines:

- » Pilot sensing line : Rp 1/4 with compression fitting for 10 mm pipe
- » Regulator sensing line : Rp 1/4" with compression fitting for 12 mm pipe
- » Regulator process line: Rp 3/8 with compression fitting for 10 mm pipe

Safety Shut-Off Valve - Overall Dimensions (mm)

SSV 8600

DN	E		C	E		C	Additional weight (kg)
	Actuator Ø 150			Actuator Ø 90			
25	150	260	90	230	4		
40	150	285	90	255	5		
50	150	285	90	255	7		
80	150	335	90	305	9		
100	150	335	90	305	10		

Vent and Sensing Lines:

- » SSV sensing line: Rp 1/4 with compression fitting for 10 mm pipe
- » SSV vent line: Rp 1/4

SSV 8500

DN	E	Suppl. poids (kg)
25	183	2
40	260	3
50	268	5
80	268	5

Vent and Sensing Lines:

- » SSV sensing line: Rp 1/4 with compression fitting for 10 mm pipe
- » SSV vent line: Rp 1/8

Type Designation And Options

To specify the version of the RB 4000 regulator to be ordered, select the options and relevant codes from the table below.

R	B	E	4	7	X	X	DN	X	X	Options
					1					Pilot TF 511
					2					Pilot TF 512
					3					Pilot TF 513
					0					Without safety device
					1					Over-pressure shut-off
					2					Over- and under-pressure shut-off
							25			Orifice (Ø 30 mm)
							40			Orifice (Ø 38 mm)
							50			Orifice (Ø 48 mm)
							80			Orifice (Ø 78 mm)
							100			Orifice (Ø 98 mm)
								S		With built-in silencer

Example: Model RBE4711 DN25 S is a regulator with a TF 511 pilot, an over-pressure shut-off and silencer.

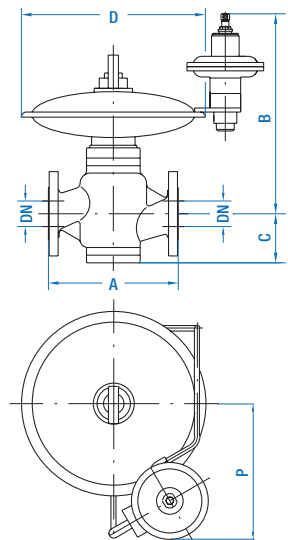

RB 4700 without SSV

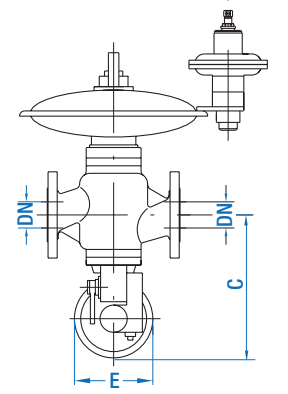

Regulator RB 4700 and SSV 8600

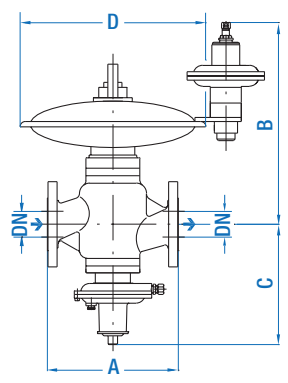

Regulator RB 4700 and SSV 8500

Installation

- | | |
|---|--|
| 1 Upstream valve | 12 Downstream pressure gauge |
| 2 Differential pressure gauge | 13 Discharge vent pipe |
| 3 Strainer / Filter | 14 Downstream valve |
| 4 Upstream pressure gauge | 15 - |
| 5 Regulator | 16 Pilot feeder sensing line
Downstream Pd |
| 6 Pilot | 17 Loading pressure line pilot->regulator |
| 7 Pressure gauge
(only with monitor installation) | 18 - |
| 8 Monitor regulator
(only with monitor installation) | 19 Safety relief valve (SRV)
optional |
| 9 Shut-off valve sensing line (SSV)
Downstream Pd | 20 - |
| 10 Regulator sensing line
Downstream Pd | 21 Inlet pressure sensing line |
| 11 Pilot sensing line (TF511/512) | 22 Monitor pilot
(only with monitor installation) |
| | 23 Shut-off valve |

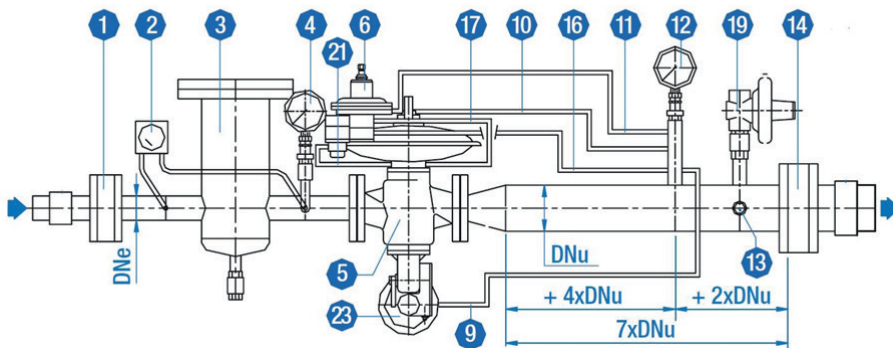

RB47xx typical installation with safety shut-off valve SSV86xx

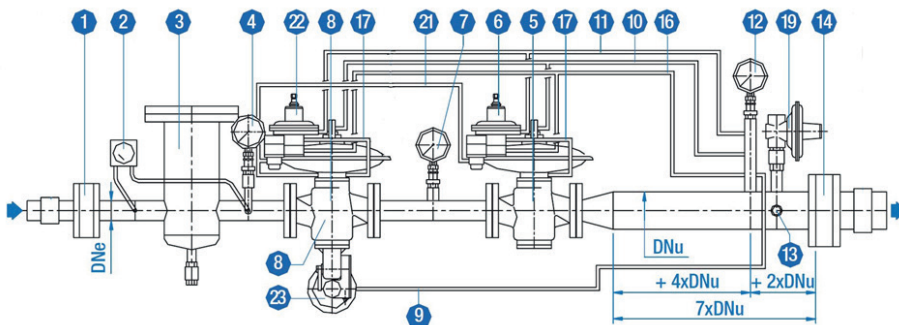

RB47xx typical installation with monitor and active regulators and safety shut-off valve SSV86xx

Information to be specified when ordering:

- » Regulator type code
- » SSV type
- » Minimum and maximum inlet pressures
- » Outlet pressure range setting
- » Outlet pressure setting
- » Connection type
- » Options
 - » OPSO setting*
 - » UPSO setting*

* (if requested)

Dresser Utility Solutions GmbH

Hardeckstr. 2
76185 Karlsruhe
T: +49 (0)721 / 5981 - 0
info.karlsruhe@dresserutility.com

