

RB 2000 Gas Pressure Regulator

3300992802

AE

Instruction Manual

Contents

Page

Declaration of conformity	4
Important safety instructions.....	6
Technical Features.....	6
Regulator Operation	7
Shut-off Valve Operation	7
Installation Procedure	8
Start-up Instruction	8
Annex.....	9

EN	FR	DE	ES	IT	PT
DECLARATION OF CONFORMITY	DECLARATION DE CONFORMITE	KONFORMITÄT SERKLÄRUNG	DECLARACIÓN DE CONFORMIDAD	DICHIARAZIONE DI CONFORMITÀ	DECLARAÇÃO DE CONFORMIDADE
Type Designation					
Gas Pressure Regulator					
Name and address of the manufacturer					
Dresser Utility Solutions GmbH, Hardeckstraße 2, 76185 Karlsruhe, Germany					
This declaration of conformity is issued under the sole responsibility of the manufacturer.					
La présente déclaration de conformité est établie sous la seule responsabilité du fabricant.					
Die alleinige Verantwortung für die Ausstellung dieser Konformitätserklärung trägt der Hersteller.					
La presente declaración de conformidad se expide bajo la exclusiva responsabilidad del fabricante.					
La presente dichiarazione di conformità è rilasciata sotto la responsabilità esclusiva del fabbricante.					
A presente declaração de conformidade é emitida sob a exclusiva responsabilidade do fabricante.					
Object of the declaration					
Objet de la déclaration					
Gegenstand der Erklärung					
Objeto de la declaración					
Oggetto della dichiarazione					
Objecto da declaração					
RB I2x10 & RBE2x10 without SS					
RBI2x11/12 & RBE2x11/12 with integrated SSV					
The object of the declaration described above is in conformity with the relevant Union harmonization legislation and the corresponding harmonized european standards					
L'objet de la déclaration décrit ci-dessus est conforme à la législation communautaire d'harmonisation applicable ainsi qu'aux normes harmonisées associées					
Der oben beschriebene Gegenstand der Erklärung erfüllt die einschlägigen Harmonisierungsrechtsvorschriften der Gemeinschaft und den entsprechenden harmonisierten europäischen Normen					
El objeto de la declaración descrita anteriormente es conforme a la legislación comunitaria de armonización pertinente y las normas armonizadas correspondientes					
L'oggetto della dichiarazione di cui sopra è conforme alla pertinente normativa comunitaria di armonizzazione e alle corrispondenti norme armonizzate					
O objecto da declaração acima mencionada está em conformidade com a legislação comunitária aplicável em matéria de harmonização e as correspondentes normas harmonizadas					
2014/68/EU (PED) article 4(3)					
-EN 334:2019					
-EN 14382:2019					
The used fluids are classified in group 1 according to article 13.					
2014/30/EU (EMC)					
-EN 61000-6-2:2019					
-EN 61000-6-3:2007/A1:2011/AC:2012					
2011/65/EU (RoHS)					
2015/863/EU (RoHS)					
-EN IEC 63000					
OJ L 189, Page 164, 27.04.2014					
OJ L 96, Page 79, 29.03.2014					
OJ L 174, Page 88, 01.07.2011					
OJ L 137, Page 10, 04.06.2015					
Certificates issued by the notified body					
Certificats délivrés par l'organisme notifié					
von der notifizierten Stelle ausgestellte Bescheinigungen					
Certificados emitidos por el organismo notificado					
Certificati rilasciati dall'organismo notificato					
Certificados emitidos pelo organismo notificado					
Place and date of issue					
Date et lieu d'établissement					
Ort und Datum der Ausstellung					
Lugar y fecha de expedición					
Luogo e data del rilascio					
Local e data da emissão					
Karlsruhe, 16.11.2023					
Name, Function, Signature					
Nom, Fonction, Signature					
Name, Funktion, Unterschrift					
Nombre, Cargo, Firma					
Nome e cognome, Funzione, Firma					
Nome, Cargo, Assinatura					



© Copyright 2023 Dresser Utility Solutions. All rights reserved.

Document no: **D2036213** AG

To check for an updated version, please visit our website at www.dresserutility.com

HU MEGFELELŐSÉGI NYILATKOZAT	RO DECLARAȚIA DE CONFORMITATE	NL VERKLARING VAN OVEREENSTEMMING	PL DEKLARACJA ZGODNOŚCI UE	CZ EU PROHLÁŠENÍ O SHODĚ
A gyártó neve és címe	Numele și adresa producătorului	Naam en adres van de fabrikant	Nazwa i adres producenta	Jméno a adresa výrobce
Ezt a megfelelőségi nyilatkozatot a gyártó kizárólagos felelőssége mellett adják ki.	Această declarație de conformitate este emisă sub responsabilitatea exclusivă a producătorului.	Deze conformiteitsverklaring wordt verstrekt onder de verantwoordelijkheid van de fabrikant.	Ta deklaracja zgodności wydana zostaje na wyłączną odpowiedzialność producenta.	Toto prohlášení o shodě se vydává na výhradní odpovědnost výrobce.
A nyilatkozat tárgya	Obiectul declarației	Onderwerp van de verklaring	Przedmiot deklaracji	Předmět prohlášení
A fent leírt nyilatkozat tárgya összhangban van a vonatkozó uniós harmonizációs jogszabályokkal és a megfelelő harmonizált szabványokkal	Obiectul declarației descrise mai sus este în conformitate cu legislația relevantă de armonizare a Uniunii și cu standardele armonizate corespunzătoare	Het onderwerp van de hierboven beschreven verklaring is in overeenstemming met de relevante harmonisatiewetgeving van de Unie en de overeenkomstige geharmoniseerde normen	Opisany powyżej przedmiot tej deklaracji jest zgodny z odpowiednimi wymaganiami unijnego prawodawstwa harmonizacyjnego	Výše popsany předmět prohlášení je ve shodě s příslušnými harmonizačními právními předpisy Unie
bejelentett szervezet által kiállított igazolások	CertIFICATE emise de organismul acreditat	Certificaten afgegeven door de aangemelde instantie	W stosownych przypadkach nazwa, adres i numer jednostki notyfikowanej	Případné certifikáty vydané oznámeným subjektem
Kiállítás helye és dátuma	Locul și data emiterii	Plaats en datum van uitgifte	miejsce i data wydania	Místo a datum vydání
Név, beosztás, aláírás	Nume, funcție, semnătură	Naam, functie, handtekening	Nazwisko, stanowisko, podpis	Jméno, funkce, podpis

Keep this manual easily accessible for all users.

Important safety instructions:

- Only use for dry and clean gases. For use with aggressive gases please contact Dresser Actaris Gas for special versions. For Hydrogen applications, after maintenance, purge the device with inert gas like nitrogen.

Never use with oxygen: Danger of explosion!

- Please respect all national standards and codes of practices for installation, operation, testing and service of gas regulators and of gas pressure regulating stations.
- Before mounting please check the regulator for possible damage due to transport. The sealing surfaces must be clean.
- Arrange enough room for the serving of the regulator.
- To protect the regulator from dirt a sieve or a filter is recommended.
- The regulator must be installed tension free in the piping.
- After installation please check the tightness of the thread connection.
- The technical data given on the name plate must be respected. If necessary safety devices must be installed.
- Repairs and maintenance must be done by trained or qualified personal. Afterwards a tightness test with 1.1 x PS must be performed. When changing pressure containing parts their compliance with the PED must be assured.
- If used with wet gas, internal and external effect of corrosion has to be checked regularly and in case of severe corrosion, the regulator has to be replaced.

- The device must be cleaned with a wet cloth only.
- Please don't use solvent or alcohol containing products to clean the regulator.
- Before removing the regulator please depressurise completely. Some gas may still be inside the regulator and the pipe, therefore sufficient ventilation is required.

REMARKS FOR USE IN POTENTIALLY EXPLOSIVE ATMOSPHERES (ATEX):

- If film of rust is possible (flying rust in the immediate regulator surroundings), all outer aluminium parts have to be protected accordingly (e.g. by varnish).
- The product must be electrically connected to adequately earthed installation.
- For installation, removing or repair of the product on site, only tools allowed for the corresponding explosion area can be used.
- The product shall not be exposed to: flames, ionised radiation and ultrasound.
- Ambient temp. conditions must be considered, including possible additional heating effects due to other devices in immediate vicinity.
- Gas pressure regulator according to DIN EN 334 - if not equipped, with any electronic device - do not have a potential ignition source and therefore are not in the scope of European directive 2014/34/EU.

Technical Features

Max inlet pressure	10 bar
Outlet pressure	7 mbar – 750 mbar
Operating temperature	-20°C to +60°C
Ambient temperature	-30°C to +60°C (body material)
Acceptable gases	Natural gas, town gas, propane, butane, dry air, nitrogen or other noncorrosive gases
Installation	Horizontal or vertical
Safety devices	Standard relief valve Optional built in safety shut-off valve: <ul style="list-style-type: none">• Over-pressure shut-off (OPSO)• Under-pressure shut-off (UPSO)
Sensing line	Internal or external
Size	1" or 1" x 1 1/2"
Connectors	Parallel internal thread according to ISO 228/1 or ISO 7/1

Regulator Operation

Regulator Operating Principle

The fluid coming from the upstream pipe enters the inlet chamber (4), passes through the opening of the valve (3) and then expands in the outlet chamber (18) flowing into the downstream pipe.

The downstream pressure, which from the chamber (18) through the pipe (17) enters the regulation diaphragm housing (14), exerts a force on the surface of the diaphragm (9) balancing the load of the calibration spring (12), enabling the valve plug (5) to find an optimum position, ensuring good regulation and the required flow rate. The series 3200 pressure regulator is fitted with a balanced compensation system, which allows constant downstream pressure regardless of variations of upstream pressure. If during the operation the flow rate increases, due to a demand, or the inlet pressure decreases, the pressure values in the chambers 18 and 14 will tend to decrease. Consequently the force of the spring (12) moves the diaphragm assembly (15) downwards and by means of the lever system (16) adjusts the position of the valve plug (5), thus resetting the pressure and the flow rate to the required values. The reverse occurs when the flow rate demand decreases.

At zero flow, rate the regulator guarantees full tightness. The regulator is also fitted with a relief valve built into the diaphragm bolder assembly (15) which, calibrated by means of the spring (13), serves to discharge externally, through the vent (10), possible over-pressure created in the chambers 14 and 18.

The capacity of this valve is limited.

Regulator Setting

The regulator is supplied with calibration values specified in the order. If a different outlet pressure is required, select the correct spring to obtain this set pressure.

Once the suitable spring (12) is installed, proceed as follows:

- **to increase the outlet pressure value:**
rotate in a clockwise direction the screwing ring (11) until the required value is read on the downstream manometer;
- **to reduce the outlet pressure value:**
proceed likewise but rotate the screwing ring in an anticlockwise direction.

It is recommended to proceed slowly waiting for the pressure to stabilize after each movement of the screwing ring.

These operations can be done either with the regulator in operation or with the downstream stop valve closed (ensuring a small vent is open downstream to give a small flow).

Shut-off Valve Operation

Operating Principle of the Shut-off Valve

The pressure regulator can be fitted with an independent shut-off valve consisting of a shutoff valve casing (21) and a diaphragm assembly (29), which controls a mechanical ball system enabling the release of the valve.

The shut-off valve is triggered when the pressure value in the chamber (22) increases or decreases beyond the pre-set values established and thus moves the entire assembly(29) from a balanced position. The stem (27), which is connected to the valve plug (19) is triggered under the force of the spring and comes immediately into contact with the orifice (2), cutting automatically the flow of the fluid.

For series 3211 the shut-off valve operates only for over-pressure shutoff; for series 3212 it operates for both over and low-pressure shut-off.

Adjustment of the Shut-off Valve

If the set values of the shut-off are to be modified, proceed as follows:

(A) over-pressure shut-off operation:

Rotate the outside shut-off screwing ring in a clockwise direction to increase the pressure values, or anticlockwise to reduce it.

(B) low-pressure shut-off operation:

Likewise but on the central shut-of screwing ring.

Resetting of the Shut off Valve

The shut-off valve must be reset only after verifying the reasons far the intervention and after having re-established normal operating conditions, proceeding as follows:

- (A) close the downstream stop valve;
- (B) remove the cover (25), unscrewing it (see fig. B1);
- (C) screw it upside down into the stem (23), until it comes into contact with the cover (see fig. B2);
- (D) continue to screw it slowly; this causes the valve to open slowly and pressure fills the downstream pipe piece;
- (E) pull the cover outwards to permit seating of the balls on the stem: this operation ensure resetting (see fig. B3);

After these operations, screw the cover to its housing (see fig. B4) and open slowly the downstream valve.

Caution: for safety reasons, the cover must absolutely be screwed to its housing, as shown in the schematic section.

Installation Procedure

Before installing the regulator it is important to

(A) clean the upstream pipe; it is recommended to install a cartridge filter upstream of the apparatus.

(B) check that the regulator has not been visibly damaged during transport.

When installing the regulator

(C) check that the flow of the gas corresponds to the arrow moulded on the body of the regulator.

Caution: in addition, the regulator must be installed according to good engineering practice. The installation must also comply with national and/or international regulations and standards.

Start-up Instruction

Caution: before start-up, the installation must be checked for leaks.

After installing the regulator, check that:

(1) the stop valves (1), downstream (11) and the bleed cock (9) are closed;

(2) the gas pressure is not higher than the allowable limits;

(3) if the apparatus is fitted with a shut-off valve, the shut-off valve must be closed;

After verifying the above mentioned points, proceed as follows:

(A) open the upstream stop valves (1) slowly and just enough to ensure a very small flow of gas; check the upstream pressure gauge (3);

(B) reset the shut-off valve (see section "Resetting the shut-off valve");

(C) check that the downstream pressure is rising slowly on the manometer (10): the downstream pressure should stop at the required pressure value or at a value a little higher;

(D) when the upstream pressure is also stabilised, slowly open the upstream stop valve (1) to a full open position;

(E) then slowly open the downstream stop valve (11). At this point the regulator is in operation.

Likewise, the process can be followed for the installation of a monitor regulator (4) in line with the working regulator (6) (see installation scheme below), keeping in mind that the manometer (5) installed between the regulators must indicate the same, or little higher, pressure value as the upstream manometer (10).

Annex

RB 2000

Schematic section

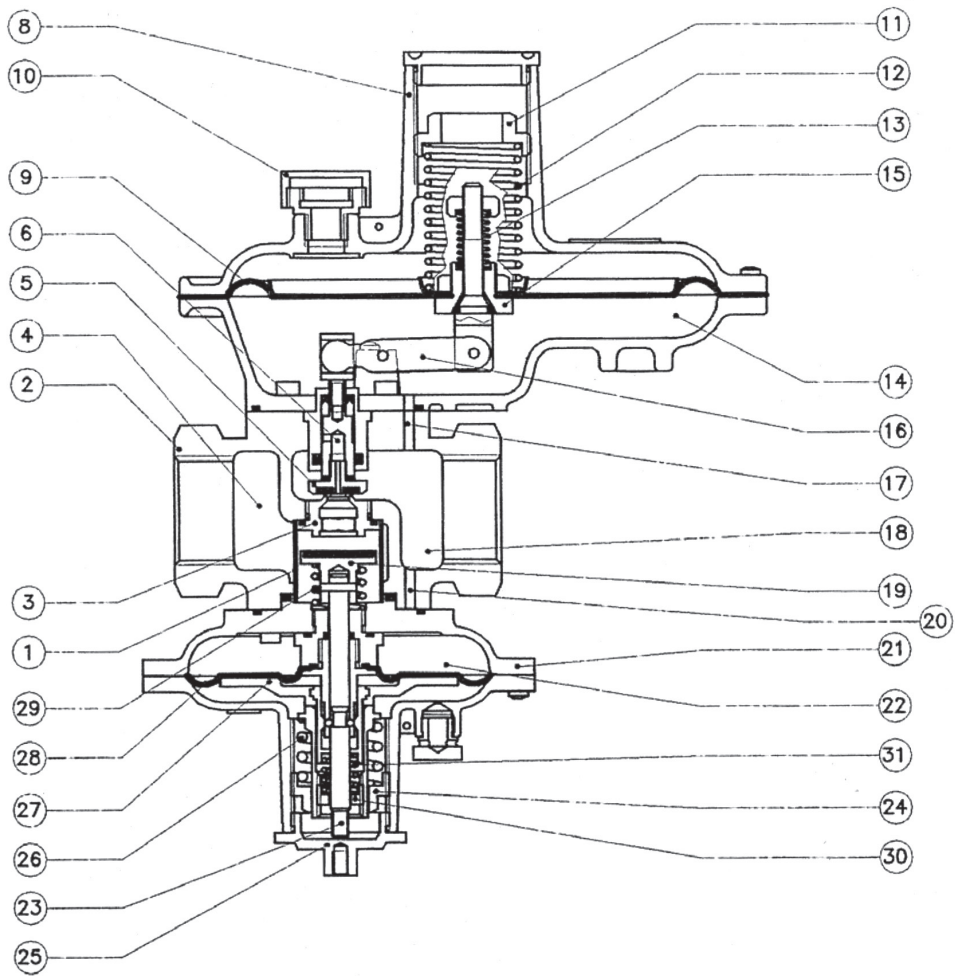

Item	Description	Item	Description
1	Body	17	Regulator sensing line port (Fig. A)
2	Filter	18	Outlet Chamber
3	Valve Seat	19	Shut-off Valve Plug
4	Inlet Chamber	20	Shut-off valve sensing line (Fig. A)
5	Valve Plug	21	Shut-off Valve Casing
6	Balancing Chamber	22	Shut-off Control Chamber
7	Drive Shaft	23	Stem
8	Cover	24	Over-pressure Shut-off screwing ring
9	Diaphragm	25	Cover
10	Vent	26	Over-pressure Shut-off Valve Spring
11	Screwing Ring	27	Shut-off Diaphragm Assembly
12	Set Point Spring	28	Safety Shut-off Valve Diaphragm
13	Safety Relief Spring	29	Shut-off Valve Closing Spring
14	Regulation Control Chamber	30	Under-pressure Shut-off Screwing Ring
15	Diaphragm Holder Assembly	31	Under-pressure Shut-off Valve Spring
16	Control Lever		

Resetting the Safety Shut-off Valve

Fig. B1, B2, B3, B4

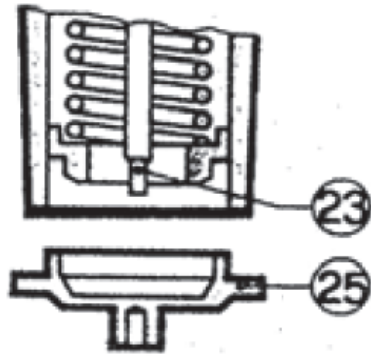

Fig. B1

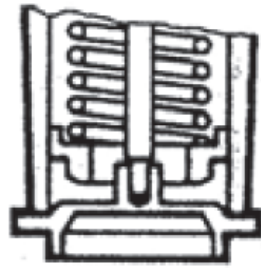

Fig. B2

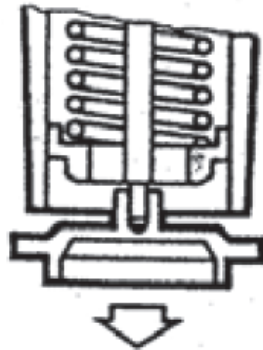

Fig. B3

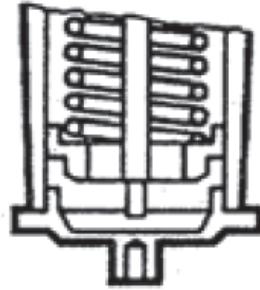
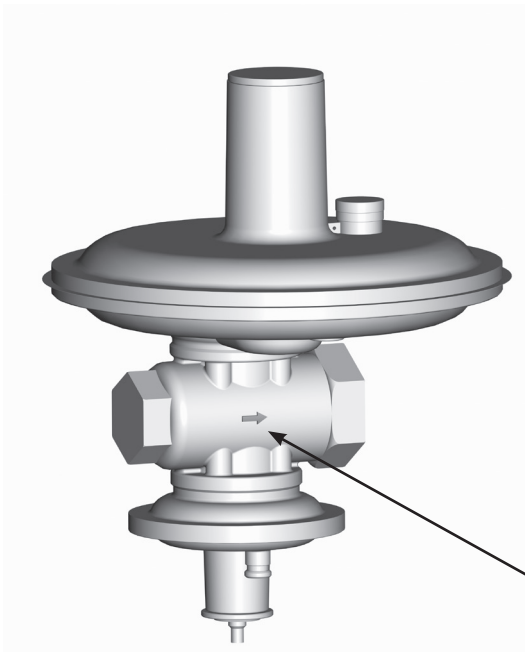

Fig. B4

Connection / Raccordement



Arrow moulded on the body

Outlet Pressure Range

Regulator

Item	L	Ext. diam.	Wire diam.	mbar		Code No.
				Cover Ø 180	Cover Ø 180/TR	
1	80	30	1.6	5 - 12	-	20564141
2	80	30	1.8	8 - 18	-	20564142
3	100	30	1.8	15 - 25	-	20564050
4	100	30	2	20 - 33	47 - 78	20564051
5	100	30	2.2	30 - 50	70 - 130	20564044
6	80	30	2.5	45 - 100	125 - 215	20564042
7	80	30	2.5	80 - 110	180 - 280	20564043
8	80	30	3	90 - 150	260 - 420	20564143
9	80	30	3.5	-	400 - 750	20564144

Safety Shut-off Valves

Over-Pressure-Shut-off Springs (OPSO)

Item	L	Ext. diam.	Wire diam.	Calibration mbar Cover Ø 120	Code. no.
1	35	25	1.5	28 - 50	20563022
2	35	25	1.7	50 - 90	20563023
3	35	25	1.9	70 - 150	20563014
4	35	25	2.2	100 - 250	20563124

Under-Pressure-Shut-off Springs (UPS0)

Item	L	Ext. diam.	Wire diam.	Calibration mbar Cover Ø 120	Code. no.
1	20	10	0.8	3 - 12	20560511
2	30	10	0.8	5 - 17	20560515
3	30	10	0.9	12 - 25	20560518
4	30	10	1	20 - 40	20560516
5	30	10	1.2	40 - 100	20560517

Relief Valve

The built in relief valve is set 10 mbar (LP) above the outlet pressure setting.

Installation Scheme

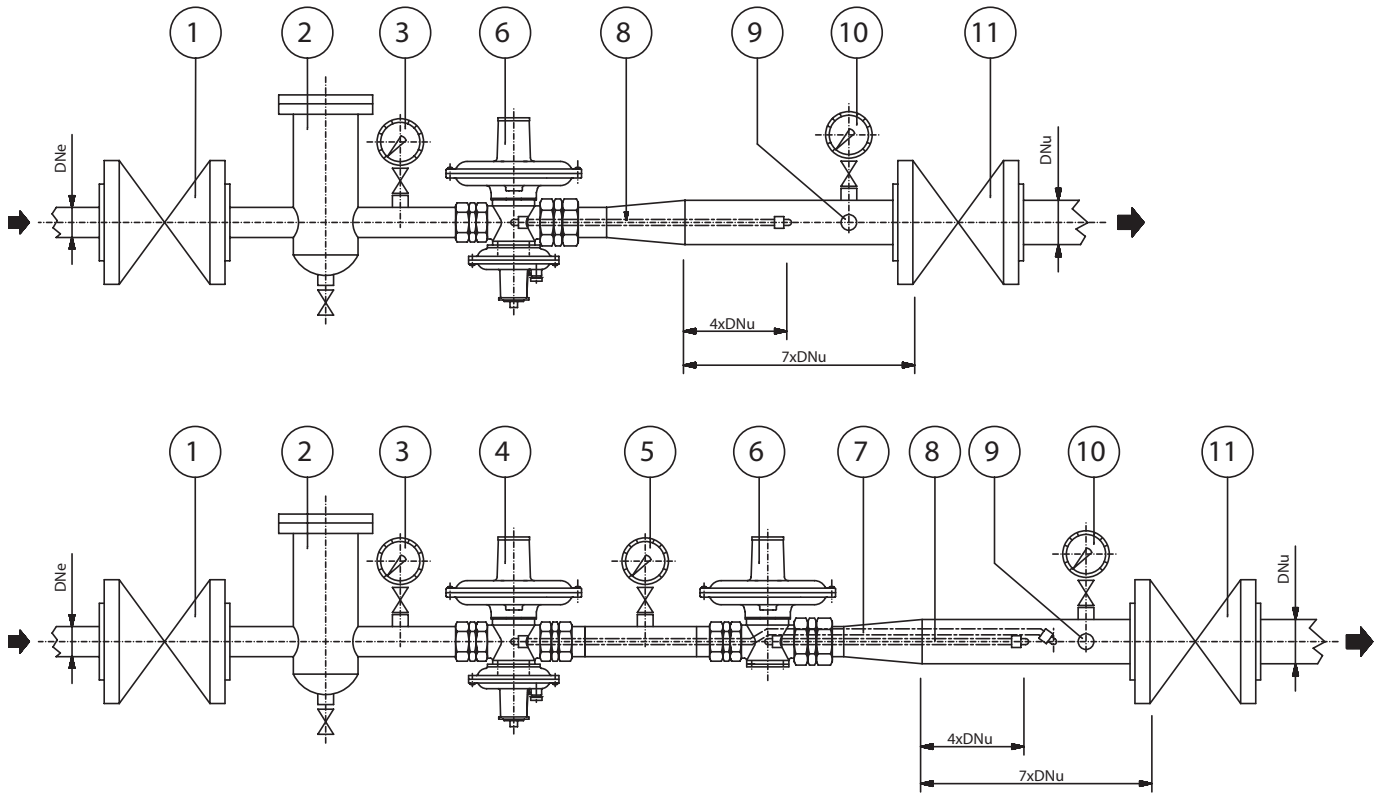

Item	Description	Item	Description
1	Upstream Stop Valve	7	Monitor Regulator Sensing line
2	Cartridge Filter	8	Regulator Sensing line Pipe
3	Manometer	9	Bleed Cock
4	Monitor	10	Manometer
5	Manometer	11	Downstream Stop Valve
6	Regulator		

Note: The installation of RB 2000 regulators does not require sensing lines.

Spare Part Kits for RB2000 Regulator

39816100	KIT RBE23xx DN 1" (after 10/2024) for RB2310, 2311, 2312
39817100	KIT RBE26xx DN 1" (after 10/2024) for RB2310, 2611, 2612
39816400	KIT RB23xx DN 1" TR (after 10/2024) for RB2310TR, 2311TR, 2312TR
39817400	KIT RB26xx DN 1" TR (after 10/2024) for RB2610TR, 2611TR, 2612TR

SSV

39816110	KIT SSV for RB2311/12 and 2611/12 (after 10/2024)
39816410	KIT SSV for RB2311/12TR and 2611/12TR (after 10/2024)

For any other spare part kits, contact your local Dresser Actaris Gas representative.

Dresser Utility Solutions GmbH

Hardeckstr. 2
76185 Karlsruhe
T: +49 (0)721 / 5981 - 100
info.karlsruhe@dresserutility.com



© 2024 Dresser Utility Solutions GmbH – All rights reserved. Dresser Utility Solutions reserves the right to make changes in specifications and features shown herein, or discontinue the product described at any time without notice or obligation. Contact your Dresser Utility Solutions representative for the most current information. The Dresser Logo and all Trademarks containing the term "Dresser" are the property of Dresser, LLC, a subsidiary of Baker Hughes. Actaris™ is a trademark owned by Itron, Inc. and used under license.