



Safety Shut-off Valve Serie 8500

3850992802

AD

Instruction Manual

Summary

EU Declaration of Conformity	4
Safety shutoff valve Serie SSV 8500	6
General Features	6
Application	6
Product description	6
Selection of SSV 8500 models	6
Technical features	7
Connections	7
Materials	7
Spring selection tables	8
Operating sketch (built-in version)	9
Overall Dimensions	10
Operation	11
Schematic section	11
SSV Operating Principle	12
Installation	13
Start-up	17
Commissioning / Reseting of the Safety Shutoff Valve	17
Setting	18
Maintenance	19
Trouble shooting	21
Part List	22
Maintenance Tools	24
Pressure loss calculation	25

EN	FR	DE	ES	IT	PT
EU DECLARATION OF CONFORMITY	DECLARATION UE DE CONFORMITE	EU KONFORMITÄTS-ERKLÄRUNG	DECLARACIÓN UE DE CONFORMIDAD	DICHIARAZIONE DI CONFORMITÀ UE	DECLARAÇÃO UE DE CONFORMIDADE

Type Designation

Safety shut off valve

Name and address of the manufacturer	Nom et adresse du fabricant	Name und Anschrift des Herstellers	Nombre y dirección del fabricante	Nome ed indirizzo del fabbricante	Nome e endereço do fabricante
--------------------------------------	-----------------------------	------------------------------------	-----------------------------------	-----------------------------------	-------------------------------

Dresser Utility Solutions GmbH, Hardeckstraße 2, 76185 Karlsruhe, Germany

This declaration of conformity is issued under the sole responsibility of the manufacturer.	La présente déclaration de conformité est établie sous la seule responsabilité du fabricant.	Die alleinige Verantwortung für die Ausstellung dieser Konformitätserklärung trägt der Hersteller.	La presente declaración de conformidad se expide bajo la exclusiva responsabilidad del fabricante.	La presente dichiarazione di conformità è rilasciata sotto la responsabilità esclusiva del fabbricante.	A presente declaração de conformidade é emitida sob a exclusiva responsabilidade do fabricante.
Object of the declaration	Objet de la déclaration	Gegenstand der Erklärung	Objeto de la declaración	Oggetto della dichiarazione	Objecto da declaração

SSV8511 / 8521 / 8531 with OPSO
 SSV8512 / 8522 / 8532 with OPSO and UPSO
 SSV8611 / 8621 / 8631 / 8641 with OPSOS
 SSV8612 / 8622 / 8632 / 8642 with OPSO and UPSO

The object of the declaration described above is in conformity with the relevant Union harmonization legislation and the corresponding harmonized standards	L'objet de la déclaration décrit ci-dessus est conforme à la législation communautaire d'harmonisation applicable ainsi qu'aux normes harmonisées associées	Der oben beschriebene Gegenstand der Erklärung erfüllt die einschlägigen Harmonisierungsrechtsvorschriften der Gemeinschaft und den entsprechenden harmonisierten Normen	El objeto de la declaración descrita anteriormente es conforme a la legislación comunitaria de armonización pertinente y las normas armonizadas correspondientes	L'oggetto della dichiarazione di cui sopra è conforme alla pertinente normativa comunitaria di armonizzazione e alle corrispondenti norme armonizzate	O objecto da declaração acima mencionada está em conformidade com a legislação comunitária aplicável em matéria de harmonização e as correspondentes normas harmonizadas
---	---	--	--	---	--

2014/68/EU (PED) -EN 14382:2019 The used fluids are classified in group 1 according to article 13.		OJ L 189, Page 164, 27.04.2014	category IV		
(EU) 2016/426 (GAR)		OJ L 81, Page 99, 09.03.2016			
2014/30/EU (EMC) -EN 61000-6-2:2019 -EN 61000-6-3:2007/A1:2011/AC:2012		OJ L 96, Page 79, 29.03.2014	only for optional electronic device		
2011/65/EU (RoHS) 2015/863/EU (RoHS) -EN IEC 63000:2018		OJ L 174, Page 88, 01.07.2011 OJ L 137, Page 10, 04.06.2015			

Certificates issued by the notified body	Certificats délivrés par l'organisme notifié	von der notifizierten Stelle ausgestellte Bescheinigungen	Certificados emitidos por el organismo notificado	Certificati rilasciati dall'organismo notificato	Certificados emitidos pelo organismo notificado
--	--	---	---	--	---

PED	Module D	TÜV SÜD Industrie Service GmbH (CE 0036); Westendstr. 199, D-80686 München			
PED / GAR	Module B - Type approval	DVGW CERT GmbH (CE 0085) Josef-Wirmer-Str. 1-3 D-53123 Bonn			
PED / GAR	Module B - Type approval	DVGW CERT GmbH (CE 0085) Josef-Wirmer-Str. 1-3 D-53123 Bonn			

Place and date of issue	Date et lieu d'établissement	Ort und Datum der Ausstellung	Lugar y fecha de expedición	Luogo e data del rilascio	Local e data da emissão
Karlsruhe, 16.11.2023					

Name, Function, Signature	Nom, Fonction, Signature	Name, Funktion, Unterschrift	Nombre, Cargo, Firma	Nome e cognome, Funzione, Firma	Nome, Cargo, Assinatura
---------------------------	--------------------------	------------------------------	----------------------	---------------------------------	-------------------------

S. Corbière
Quality Manager



HU	RO	NL	PL	CZ
EU-MEGFELELŐSÉGI NYILATKOZAT	DECLARAȚIA UE DE CONFORMITATE	EU VERKLARING VAN OVEREENSTEMMING	DEKLARACJA ZGODNOŚCI UE	EU PROHLÁŠENÍ O SHODĚ

A gyártó neve és címe	Numele și adresa producătorului	Naam en adres van de fabrikant	Nazwa i adres producenta	Jméno a adresa výrobce
Ezt a megfelelőségi nyilatkozatot a gyártó kizárólagos felelőssége mellett adják ki.	Această declarație de conformitate este emisă sub responsabilitatea exclusivă a producătorului.	Deze conformiteitsverklaring wordt verstrekt onder de verantwoordelijkheid van de fabrikant.	Ta deklaracja zgodności wydana zostaje na wyłączną odpowiedzialność producenta.	Toto prohlášení o shodě se vydává na výhradní odpovědnost výrobce.
A nyilatkozat tárgya	Obiectul declarației	Onderwerp van de verklaring	Przedmiot deklaracji	Předmět prohlášení

A fent leírt nyilatkozat tárgya összhangban van a vonatkozó uniós harmonizációs jogszabályokkal és a megfelelő harmonizált szabványokkal	Obiectul declarației descrise mai sus este în conformitate cu legislația relevantă de armonizare a Uniunii și cu standardele armonizate corespunzătoare	Het onderwerp van de hierboven beschreven verklaring is in overeenstemming met de relevante harmonisatiewetgeving van de Unie en de overeenkomstige geharmoniseerde normen	Opisany powyżej przedmiot tej deklaracji jest zgodny z odpowiednimi wymaganiami unijnego prawodawstwa harmonizacyjnego	Výše popsany předmět prohlášení je ve shodě s příslušnými harmonizačními právními předpisy Unie
--	---	--	--	---

bejelentett szervezet által kiállított igazolások	Certificate emise de organismul acreditat	Certificaten afgegeven door de aangemelde instantie	W stosownych przypadkach nazwa, adres i numer jednostki notyfikowanej	Případné certifikáty vydané oznámeným subjektem
---	---	---	---	---

SSV8500
SSV8600

DGR-0036-QS-955-23
CE-0085CO0198
CE-0085CO0044

Kiállítás helye és dátuma	Locul și data emiterii	Plaats en datum van uitgifte	miejsce i data wydania	Místo a datum vydání
---------------------------	------------------------	------------------------------	------------------------	----------------------

Név, beosztás, aláírás	Nume, funcție, semnătură	Naam, functie, handtekening	Nazwisko, stanowisko, podpis	Jméno, funkce, podpis
------------------------	--------------------------	-----------------------------	------------------------------	-----------------------

General Features

Application

The safety shut-off valve (SSV) of 8500 series is self-operated, direct acting, spring loaded safety device designed for use in gas distribution and pressure regulation systems with network pressure up to 16 bar for DN25,40 and up to 6 bar for DN50,80.

The device operates with a diaphragm control unit and is fitted with an external manual reset according to EN 334 standard. The integrated by-pass system allows relative easy resetting of the shut-off valve. Accurate operation, compact design and quite simple maintenance are the main benefits to use this product.

SSV 8500 has an application as solo version or as integrated in regulator (upstream side), but independent safety device (example: RB4000 / 4700 / 4600 Series regulators).

Product description

SSV 8500 protects the downstream pipe against over-pressure or low pressure failures. When the downstream pressure increases or decreases beyond the pre-adjusted values the safety shut-off valve interrupts immediately the gas flow.

Selection of the ssv 8500 models

8	5	X	X	Application	Head, mm:	Adjustable Range:	
						OPSO	LPSO
		1		Low pressure	Ø 150	25 – 200 mbar	9 – 60 mbar
		2		Medium pressure	Ø 90	0,13 – 3,15 bar	0,10 – 1,10 bar
		3		High pressure	Ø 90/TR	1,25 – 5,60 bar	0,15 – 2,50 bar
			1		OPSO		
			2		OPSO + LPSO		

Technical features

- Inlet pressure range: see table

	Body:	DN25	DN40	DN50	DN80
P_{zul}	Steel	25 bar			
	Cast iron	19,2 bar			
$P_{e(max)}$		16 bar	16 bar	6 bar	6 bar

- Acceptable gases
Natural gas, town gas, propane, butane, air, nitrogen or any non-corrosive gas
Use only for dry and clean gas.
- Installation
Any orientation

Connections

- Sizes
DN 25 / 40 / 50 / 80
(Body lengths according to EN 334)
- Type
Flanges (according to ISO 7005) :
cast iron PN16 / ANSI 150 (PN20) RF
cast steel PN16 / ANSI 150 (PN20) PN25 RF

Materials

- Body
Cast- iron spheroid graphite EN-GJS-400-18LT
Cast steel G20Mn5N
- Casing and cover
Aluminium or Cast iron
- Diaphragm
Polyester Fabric
- O-rings
Nitril rubber / Viton
- Valve plug
Stainless Steel / Perbunan
- Valve seat and Stem
Stainless Steel
- Adjustment ring
Brass
- Other internal parts
Stainless steel and Brass

Spring selection tables

OVER PRESSURE SHUT-OFF SPRING / OPSO

Characteristics of the springs					W _{ho} (mbar)	W _{ho} (bar)	
Code	d mm	De mm	Lo mm	lt (ø 150)	8511 /12	8521/22 (ø 90)	8531/8532 (ø 90/TR)
20565225	2	35	50	6	25 ÷ 49	0.13 ÷ 0.24	-
20565125	2.5	35	50	6	44 ÷ 120	0.20 ÷ 0.46	-
20565126	3	35	50	6	95 ÷ 200	0.42 ÷ 0.90	-
20565127	3.5	35	50	6	-	0.83 ÷ 1.84	1.25 ÷ 3.00
20565128	4	35	50	6	-	1.32 ÷ 2.25	2.30 ÷ 4.20
20565129	4.5	35	50	6	-	2.28 ÷ 3.15	3.60 ÷ 5.60

LOW PRESSURE SHUT-OFF SPRINGS / LPSO

Characteristics of the springs					W _{ho} (mbar)	W _{ho} (bar)	
Code	d mm	De mm	Lo mm	lt (ø 150)	8511 /12	8521/22 (ø 90)	8531/8532 (ø 90/TR)
20561022	1.2	15	35	7.75	9 ÷ 19	-	-
20560815	1.3	15	35	8	14 ÷ 30	0.10 ÷ 0.25	0.15 ÷ 0.40
20561023	1.5	15	35	7.75	28 ÷ 60	0.20 ÷ 0.40	0.30 ÷ 0.60
20561024	1.8	15	35	7.5	-	0.40 ÷ 0.70	0.58 ÷ 1.25
20561121	2	15	35	7.25	-	0.60 ÷ 1.10	1.20 ÷ 1.70
20561122	2.5	15	35	7.2	-	-	1.08 ÷ 2.50

ATTENTION:

Tables 1 and 2 are valid for adjustment of „solo“ models of ssv 8500.

For „integrated in regulator“ versions (by RBE 4000 / 4700 / 4600 regulators) please refer to the technical documentation of these regulators.

Fig. 2

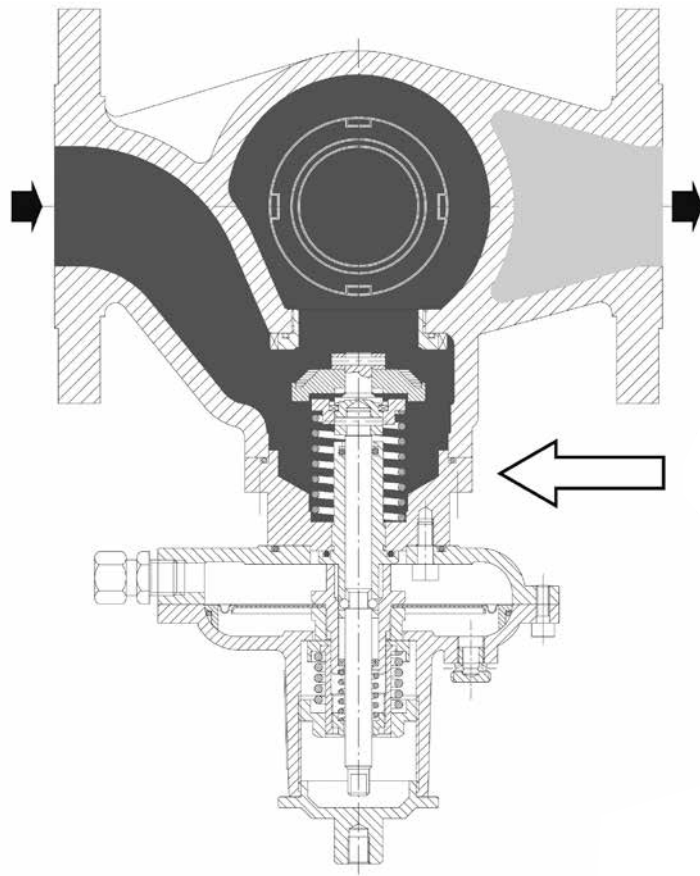

Built-in SSV 8500
by RB 4000 Regulator

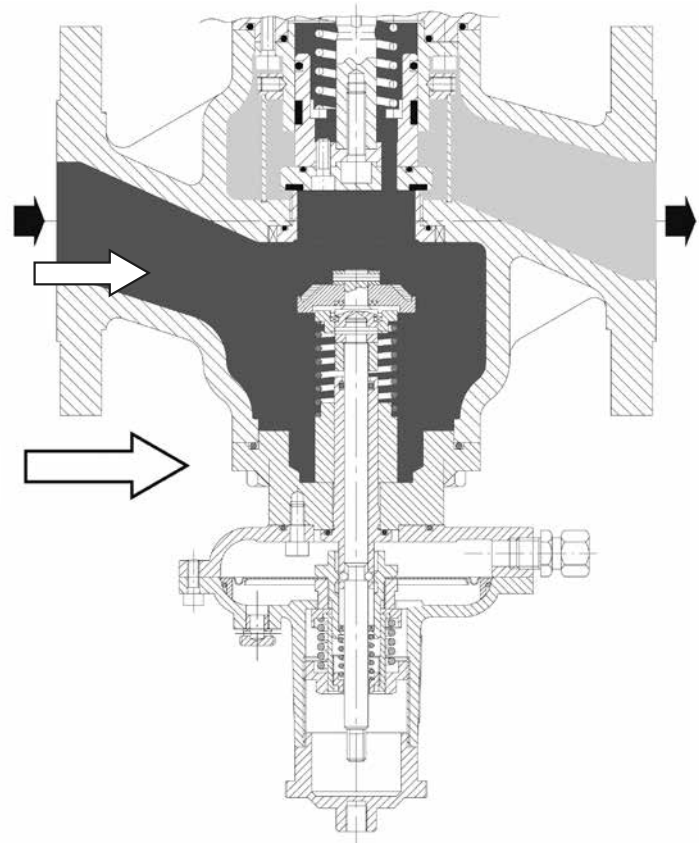

Built-in SSV 8500
by RB 4700 Regulator

- - Inlet pressure
- - Outlet pressure

Overall Dimensions

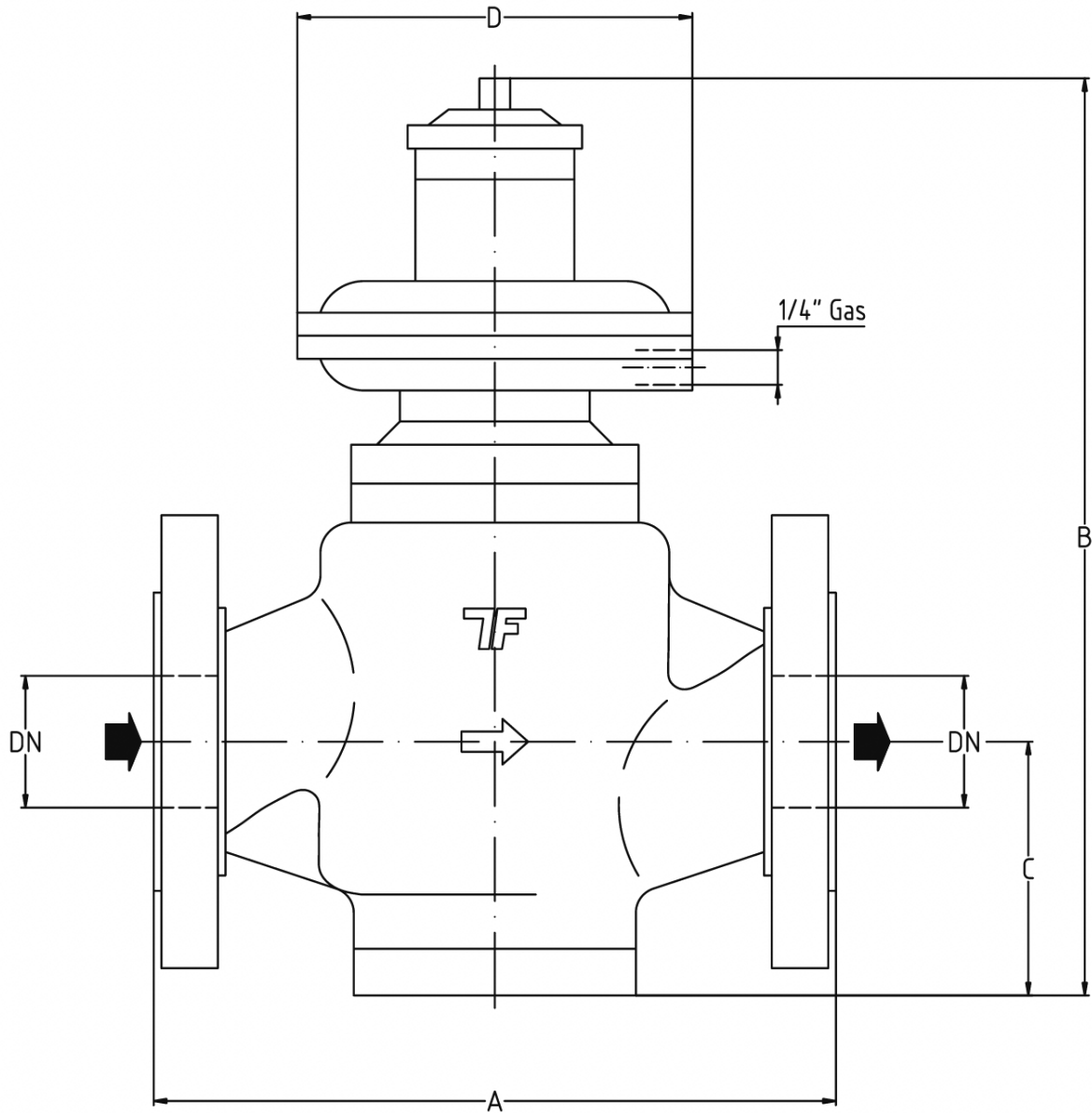

Type	8551 / 8512				8521 / 8522-8531 / 8532				
	DN	25	40	50	80	25	40	50	80
A	184	222	254	298	184	222	254	298	
B	300	330	360	420	300	330	360	420	
C	70	90	100	130	70	90	100	130	
D	150	150	150	150	90	90	90	90	
Weight (kg)	11	15	18	32	11	15	18	32	

Schematic section

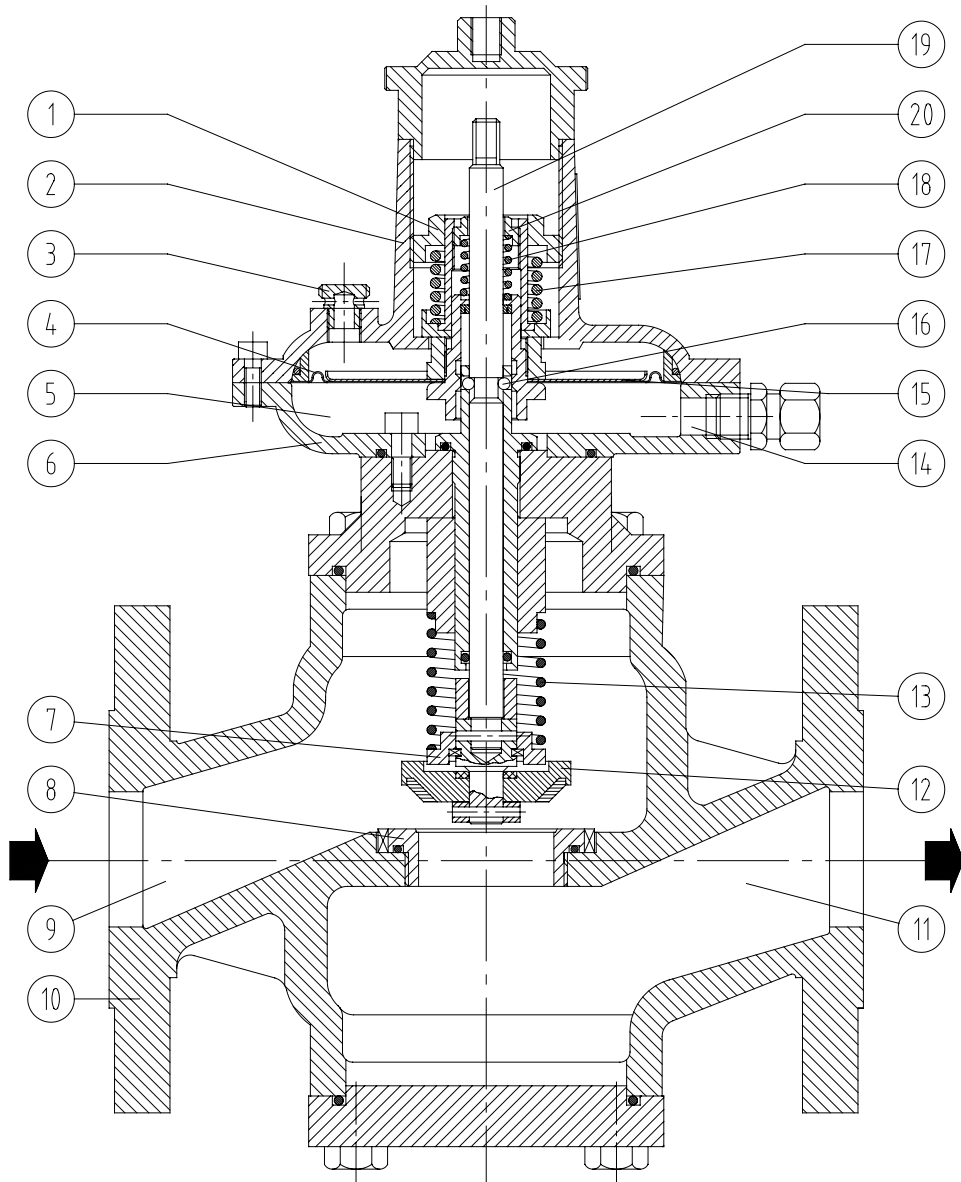

SSV Operating Principle

Safety Shut-off Valve 8500 (SSV 8500) is designed as independent safety device in order to protect the downstream pipe against over- or lover-pressure failures by immediately stopping of the gas flow.

This happens as soon as the downstream pressure reaches the pre-adjusted over pressure (OPSO) or low pressure (LPSO) set points.

The SSV is open in the normal working conditions.

The pressure to be controlled is entering through the impulse intake (14) to the shut-off control chamber (5) under the diaphragm (4). In this chamber the

downstream pressure is compared with the pre-adjusted set values for over pressure- (spring 17) and low pressure shutoff (spring 18).

The diaphragm (4) is moving from the balanced position as soon as the controlled downstream pressure increases or decreases beyond the established (preadjusted) values. The fixed by mechanical ball system stem group (19) trips from its position and under the force of the closing spring (13), the valve plug (12) is brought in the contact with the valve seat (8). The flow of gas is immediately interrupted.

After closing of SSV no self- or remote resetting is possible. This can be done only manually and directly on the field.

Item	Description
1	Screwing ring (OPSO)
2	Cover
3	Breathin vent
4	Diaphragm
5	Control chamber
6	Diaphragm housing
7	By-pass
8	Orifice (Valve seat)
9	Inlet chamber
10	Body

Item	Description
11	Outlet chamber
12	Valve plug
13	Closing spring
14	Impulse intake
15	Diaphragm plate
16	Balls
17	Over-pressure adjustment spring
18	Low-pressure adjustment spring
19	Stem
20	Screwing ring (LPSO)

Installation

All delivered Safety shut-off valves SSV 8500 are produced, checked for resistance and tightness, and adjusted in accordance with the requirements of EC Pressure Equipment Directive 97/23/EG.

In any case the acting national norms and standards about installation, start-up and maintenance of the safety devices and gas installations have to be strictly respected.

The handling with the safety shut-off valve has to be done carefully.

The pick up has to be made by using the stretcher eyes or belts.

Installing of the device in the piping must be performed by respecting the following points:

- the upstream and downstream flanges have to be parallel and the safety device
- must be capable of being fitted without any mechanical stress;
- the mentioned below torque's values for screws must be respected by tighten of the flanged connections:

- these torque's values are mentioned per screw and are valid for metal soft material gaskets (specified as k0xKD=45bD und k1=2,2bD); other gaskets can require another torque's values.
- The screws used for the flange connection must be according to the flange size
- and must be adapted to the temperature range of the SSV; please tighten the screws crosswise.
- the upstream piping and connecting lines have to be cleaned from all possible impurities (welding slag, sand, etc..)
- to prevent any damage of safety device and function failure;
- to check if the safety device is not visibly damaged (for example after transportation); possible lacquer damage should be improved; the sealing surfaces of the flanges must be damage-free and clean;
- the inlet and outlet chambers of the safety device body have to be also perfectly clean;
- the functional characteristics indicated on the name plate must correspond to
- the installing and operating conditions;
- direction of gas flow has to correspond to the arrow on the safety device body.

	DN 25	DN 40	DN 50	DN 80
PN16	35Nm (M12)	85Nm (M16)	85Nm (M16)	85Nm (M16)
ANSI150	55Nm (M14)	55Nm (M14)	85Nm (M16)	85Nm (M16)
PN25	35Nm (M12)	85Nm (M16)	85Nm (M16)	85Nm (M16)

Fig. 5

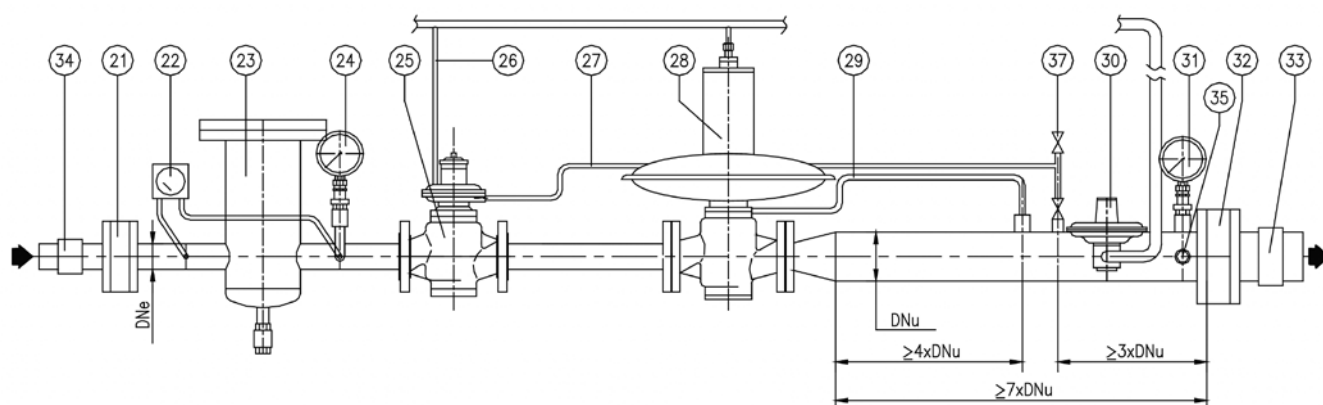
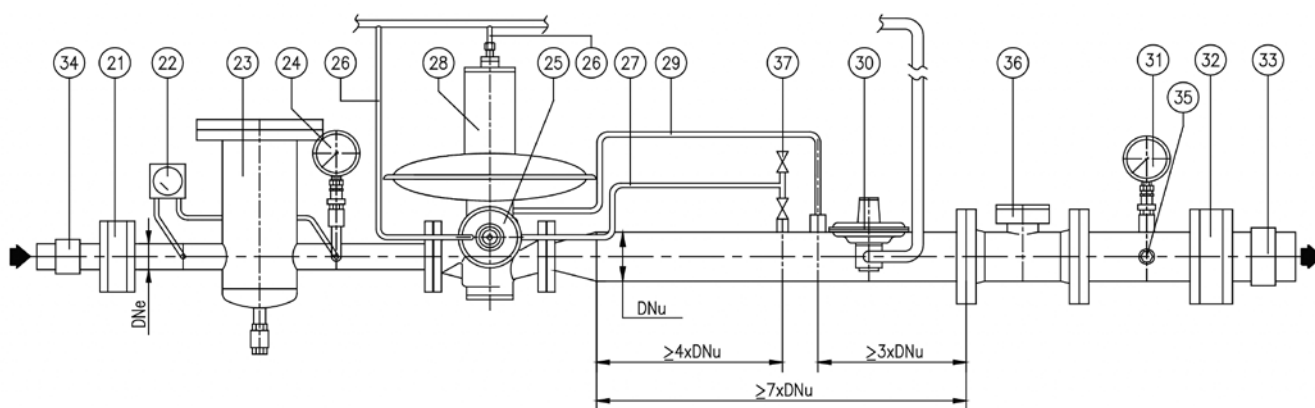

Fig. 6



Position	Description
21	Upstream valve
22	Differential pressure manometer
23	Filter
24	Upstream manometer
25	Safety shut-off valve
26	Breathing line
27	Impulse line (SSV)
28	Regulator

Position	Description
29	Impulse line (Regulator)
30	Safety relief valve (SRV)
31	Downstream manometer
32	Downstream valve
33	Downstream isolating connection
34	Upstream isolating connection
35	Discharge vent
36	Meter
37	Discharge vent

The Safety shut-off valve can be installed in the horizontal (we recommend) or vertical way.

Remark: „horizontal way“ means in this case inlet and outlet flanges have the horizontal alignment.

The device should be not impaired in its function by other installation components. In particular the effectiveness/operability must be ensured by measuring and breathing lines each time.

To install the safety device the following should be provided:

- an electrically insulating joint upstream and downstream, if the incoming and outgoing piping are made from ferrous material;
- an on/off valve on the upstream and downstream side of the piping;
- impulse sensing line of the safety device has to be connected to the turbulence free zone of the downstream side;
- breathing lines (by indoor installations);
- a manometer or pressure gauge on the upstream and downstream side of the piping;
- an upstream filter;
- a pressure intake downstream for startup and changes in pressure setting;
- electrical earthing of the unit;
- free passage for service, reading of the name plates and maintenance operations;
- all variations in diameter downstream must be performed progressively in order to prevent negative turbulence of the gas flow.

To avoid:

- Sitting of the impulse pipe near sources of heat or direct sun light.

Pay attention that:

- an emergency relief valve for accidental over-pressure (for example: regulator failure) must be installed with exhausting volume, which has to be min. 1% of the max. regulator capacity; the relief valve has to be installed in the way to exclude any danger of the gas, which could be exhausted (for example: put exhausting line on SRV by indoor installation);
- The device is not appropriate for floods. Appropriate measures must be seized by flood danger.
- The device is not appropriate for loads by earthquakes. In the case of earthquake danger appropriate measures must be seized as well.
- In case when no breathing lines are connected (outdoor installation) some volume of gas could go out from SSV (for example by diaphragm rupture). Should be this a potential danger, an appropriate measures have to be insured to evade such danger.

To connect the impulse sensing lines:

We recommend to use for impulse sensing lines the 8/10 pipes, which can be connected to the impulse intake (14), DN 1/4" and to downstream pipe to the pressure intake (plug connection DN 1/4") as shown on the Figure 7.

These connections must be inserted in a straight section of the downstream pipe.

For this purpose we recommend welding the impulse connections on the upper part of the piping in order to prevent impurities and condense, which can be collected and obstruct the passage of the gas.

It is also important to make sure that the impulse sensing line slopes slightly downwards to the pipe.

For adequate operation, the gas velocity at the impulse position in the pipe, must not exceed the following values:

Low pressure	
< 200 mbar	15 - 20 m/s
Medium / high pressure	
> 200 mbar	20 - 40 m/s

After installing of the safety device and connecting of all pressure lines (includ. breathing lines if required), the complete system has to be checked for tightness. If necessary, to pull additionally tight the flanged connections.

At this stage, Safety shut-off valve is ready for start-up procedure (resetting).

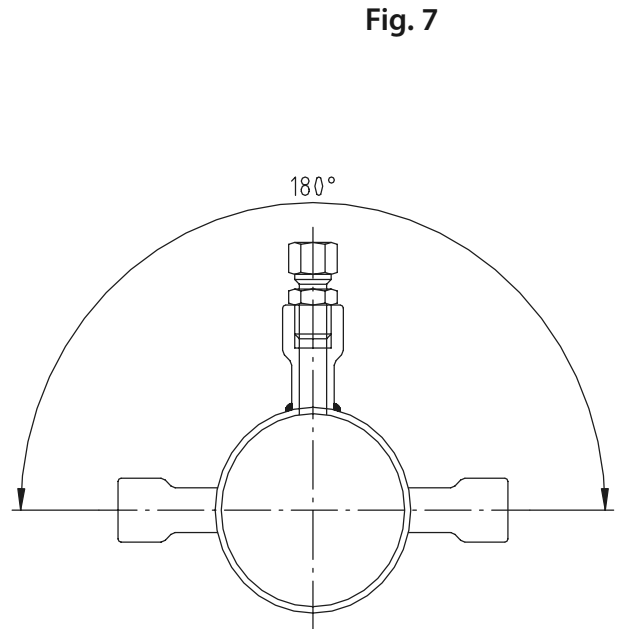
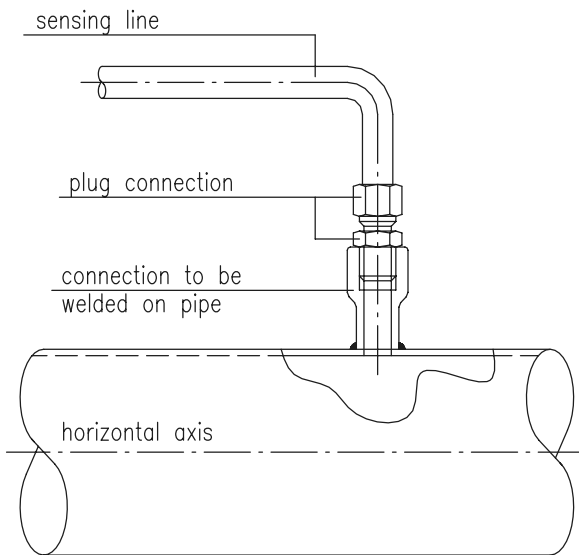

Fig. 7

Start-up

Commissioning / Resetting of the Safety Shutoff Valve

Safety shut of valve SSV8500 can be delivered having only OPSO safety (over pressure shut-off) or both OPSO + LPSO (over and low pressure shut-off). To identify the delivered model refer please to „Selection of the SSV 8500 models“ on the page 5 if required.

SSV having only OPSO safety is normally before use in the „opened“ position and ready to start-up.

SSV having both OPSO and LPSO safeties must be in „closed“ position before any use. Therefore resetting has to be done to start-up.

If the safety valve has been shut-off (in network) reset must be made only after verifying the reasons for the intervention and after having re-established normal working conditions.

In such case commissioning and reset must be done as follows (see please Fig. 5 and Fig.8):

1. close the downstream stop valve (32);
2. open the taps of the manometers (24) and (31)

3. if necessary discharge remaining downstream pressure by the mean of discharge vent (35)
4. check the internal tightness of SSV valve plug by opening the vent (37) (test with soap blows)
5. remove the cover (21) unscrewing it (see please Figure 8);
6. screw it upside down on the stem (19) until it comes into contact with the cover (21);
7. continue to screw it slowly until the internal by-pass is open;
8. with this operation pressure fills the downstream pipe and control chamber (5) and equilibrates the pressure on the both sides of valve plug (12). This can be checked on the manometer (31) of the downstream side (increase of the pressure);
9. pull the cover outwards to permit seating of the balls (16) on the stem (19);
10. screw the cover to its housing and proceed slowly with opening of the downstream valve (32); the Safety shut-off valve is in operation.

Attention: for safety reasons, during operation, the cover must be screwed to its housing as shown on the Fig. (i).

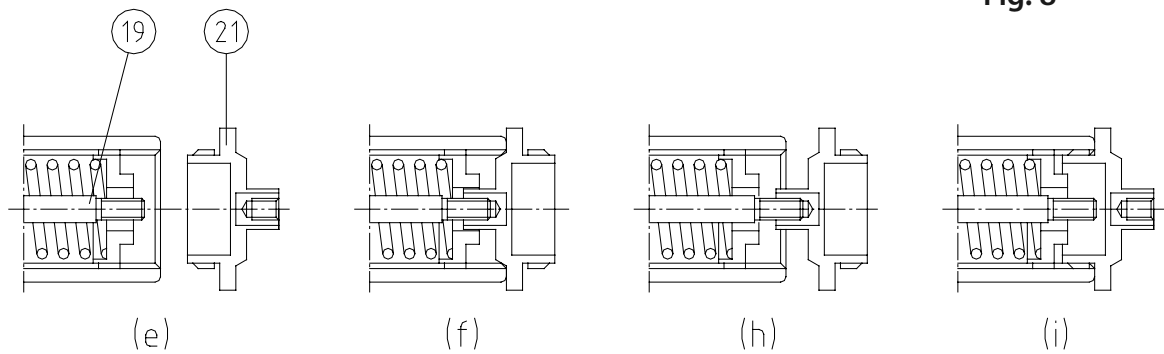

Fig. 8

Setting

The Safety shut-off valve is as rule supplied with calibration values specified in the order.

Should be necessary to modify the calibration value, it must be considered that the modification can effected only within the calibration range of the spring installed, otherwise it is necessary to substitute it with a suitable spring to be selected referring to the tables on the page 10.

When the installed spring is appropriate to obtain the required pressure, proceed as follows:

• Over-pressure shut-off (OPSO):

1. close the downstream valve (32) and increase progressively the downstream pressure till reaching the required value for OPSO;
2. to change this value, rotate in a clockwise direction the external screwing ring (1) in order to increase the calibration value or in an anticlockwise direction to reduce it.

• Low-pressure shut-off (LPSO):

1. close the downstream valve (32) and exhaust progressively the downstream pressure till reaching the required value for LPSO;
2. to change this value, rotate in a clockwise direction the internal screwing ring (20) in order to increase the calibration value or in an anticlockwise direction to reduce it.

Important: The changing of the setting of the shut-off valve must always be performed with the diaphragm control chamber (5) under pressure.

To verify the adjusted set points, actuate the Safety shut-off valve two or three times checking that it springs up to the required pressure value.

Maintenance

Maintenance and repairs of the device are allowed to be made only by trained or qualified

personal. Afterwards a tightness test with 1.1 X PS must be performed.

When changing pressure containing parts their compliance with PED must be assured.

After Guarantee only with repair by Dresser Actaris Gas.

The maintenance works required for the Safety shut-off valve are closely linked to the quality of gas supplied (moisture content, liquid hydrocarbons, impurities in general) and the degree of filtration performed upstream of the safety device.

For this reason, we recommend always installing of a cartridge filter upstream of the safety device, which is capable of withholding the solid and liquid particles present in the gas.

We also recommend performing routine preventive maintenance at established intervals in accordance with:

- the quality of the gas supplied;
- importance of the service rendered,;
- reliability required;
- condition and cleanliness of the piping that supplies the gas to the system.

Recommended maintenance intervals (can differ depending on the above listed factors) are mentioned in the table here below:

Maximum upstream pressure	Maximum flow capacity	Monitoring			Maintenance
		Visual control	Inspection	Functional check	
bar	m ³ /h				
≤ 0,1	-	As requested			
> 0,1 – 1	≤ 100	As requested		twelve-annually	As requested
	> 100			four-annually	eight-annually
> 1 – 4	≤ 100	As requested		six-annually	As requested
	> 100			two-yearly	four-annually
> 4– 16		quarterly	half-yearly	annually	two-yearly

- The device has to be also regularly examined for corrosion danger in the interior and external area and be taken from use if noticeable corrosion is discovered.
- The device must be cleaned with a wet cloth only. Please don't use solvent or alcohol containing products to clean the regulator.

All pressures must be discharged before performing any maintenance operation on the safety device! In case of device disassembly, the rest of gas can withdraw, therefore the required ventilation has to be insured.

Therefore proceed in the following way (see please Figures 5 and 8):

- close the on/off valves upstream and downstream (21) and (32);
- slowly discharge the pressure by opening the discharge valve (35) downstream from the safety device till the downstream manometer (31) shows „0“ value;
- if safety device is equipped with over- and lower-pressure shut off (OPSO + LPSO), the resetting of SSV must be done to open the by-pass (7) between the inlet and outlet chambers (see the paragraph „Commissioning / Resetting of the safety shut-off valve“). This permits the discharge of pressure upstream of the safety device that is otherwise kept by the intervention of the low pressure shut-off (LPSO).

Before to start the maintenance works:

- be sure that all required wrenches and other necessary tools are close at hand
- to perform the operations;
- spare parts to replace the damaged one are immediately available.

During the maintenance works:

- disassemble all parts carefully in order to avoid any damage;
- pay extra attention to the rubber parts (by using appropriate tool for the disassembly of the O-rings);
- replace all parts that exhibit even the slightest signs of damage.

In the event of malfunction check the trouble-shooting diagram to identify the cause of the malfunction.

REMARKS FOR USE IN POTENTIALLY EXPLOSIVE ATMOSPHERES (ATEX):

- If film of rust is possible (flying rust in the immediate regulator surroundings), all outer aluminium parts have to be protected
- accordingly (e.g. by varnish).
- The product must be electrically connected to adequately
- earthed installation.
- For installation, removing or repair of the regulator on site, only
- tools allowed for the corresponding explosion area can be used.
- The regulator shall not be exposed to: flames, ionised radiation and ultrasound.
- Ambient temp. conditions must be considered, including possible additional heating effects due to other devices in immediate vicinity.
- Safety devices according DIN EN 14382 - if not equipped, with any electronic device – do not have a potential ignition source and therefore are not in the scope of European directive 2014/34/EU.

Trouble shooting

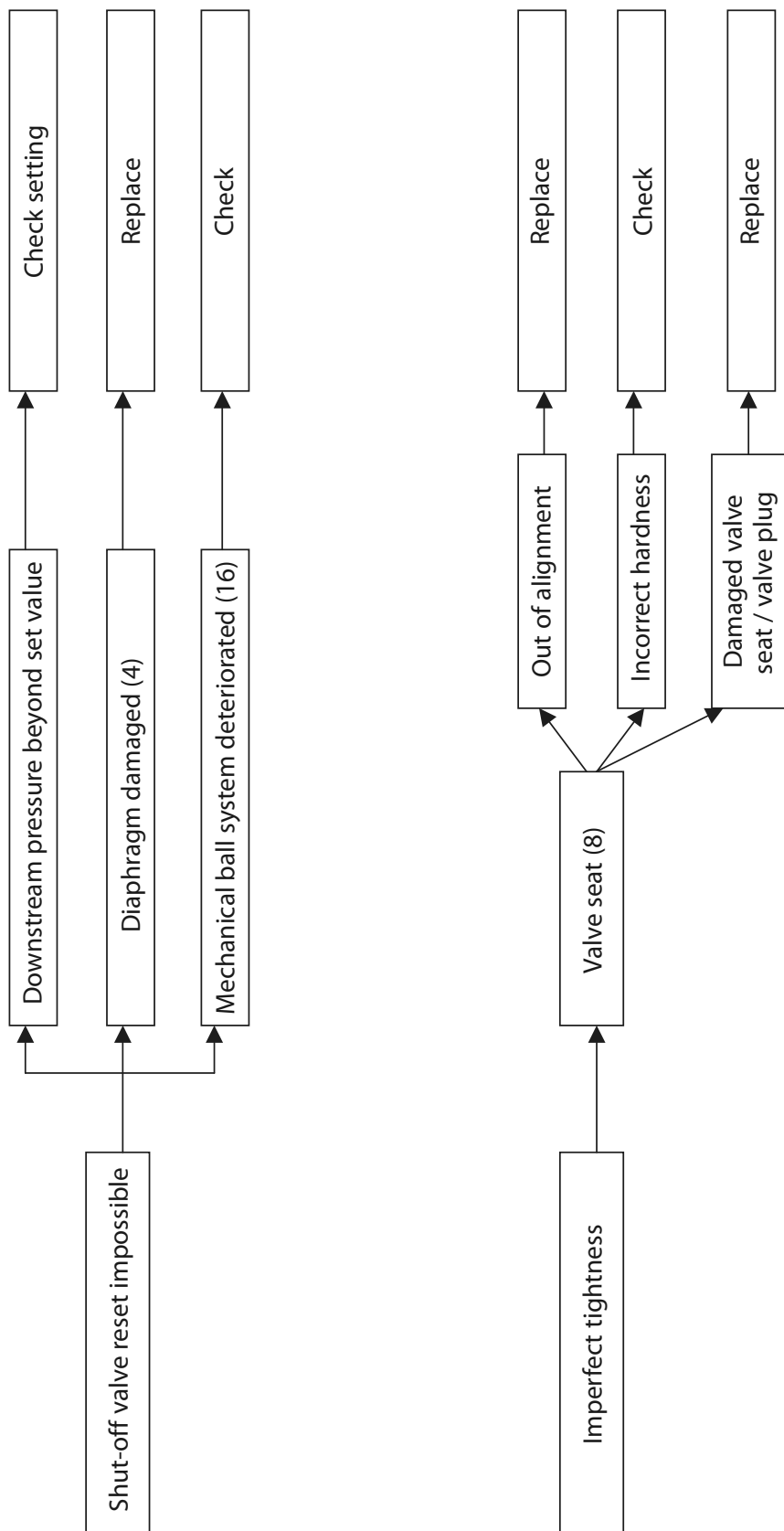

Part List

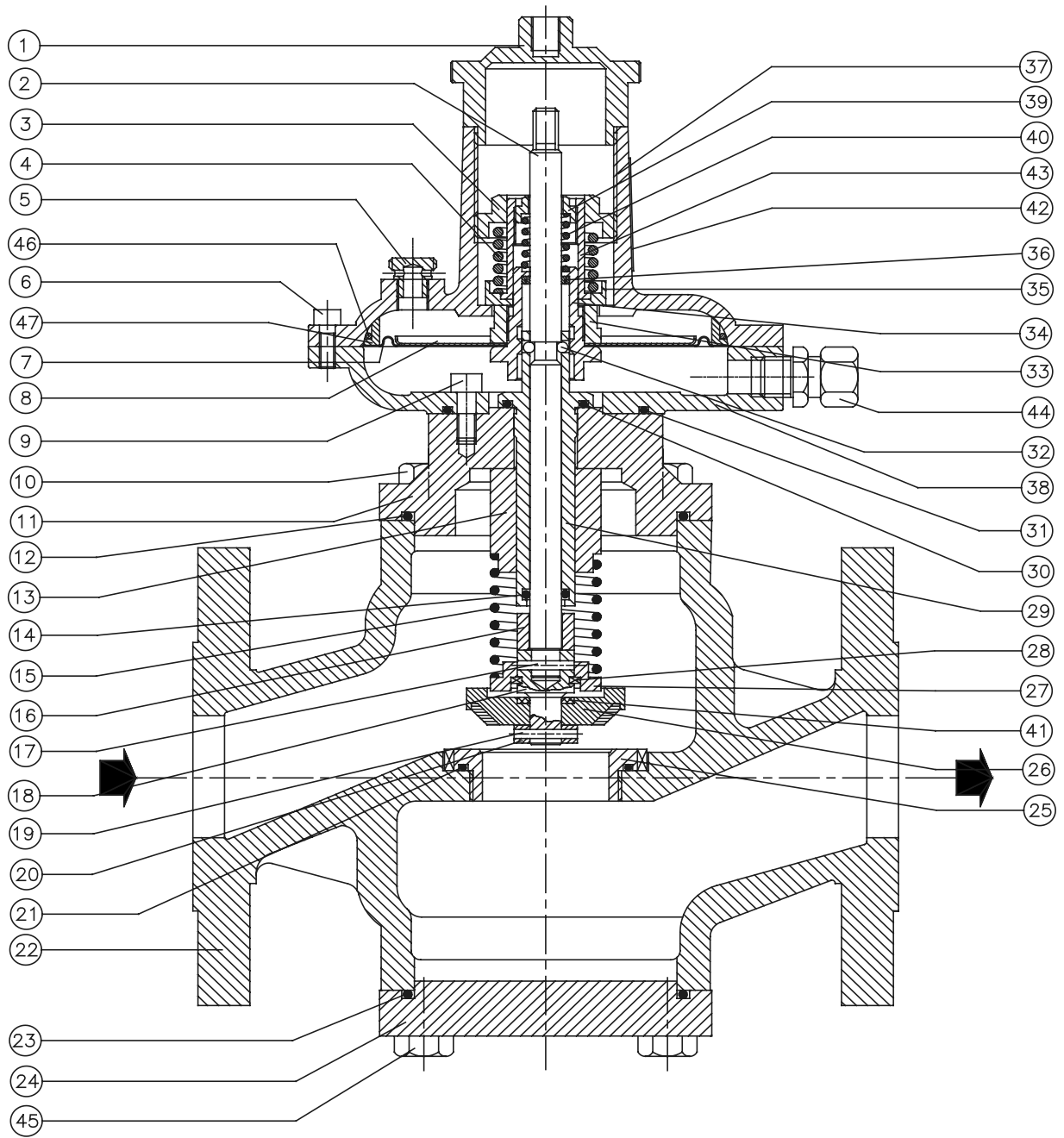

Refer to Fig. 10, 11 and 12

Item:	No:	Description
1	1	Cover
2	1	Stem
3	1	Adjustment ring (OPSO)
4	1	Spring (OPSO)
5	1	Breathing vent
6	8	Screw
7	1	Diaphragm
8	1	Disk
9	4	Screw M6 * 16
10	4	Screw M8 * 20
11	1	Plate
12	1	O-ring 170
13	1	Spacer
14	1	O-ring 112
15	1	Closing spring
16	1	Spacer
17	1	Steve
18	1	Washer
19	1	Elastic pin 3 * 20
20	1	Washer
21	1	O-ring 3150
22	1	Flange
23	1	O-ring 170
24	1	Plate
25	1	Valve (Orifice)
26	1	Valve plug
27	1	Horn block
28	1	Horn block
29	1	Stem holder
30	1	O-ring 3087
31	1	O-ring
32	6	Ball 5/32"
33	1	Nut
34	1	Holder
35	1	Disk
36	1	Ring "10"
37	1	Cover
38	1	Diaphragm housing
39	1	Adjustment ring (LPSO)
40	1	Spring (LPSO)
41	1	Washer
42	1	Name plate
43	2	Horn block
44	1	Impulse line connection
45	4	Screw M8 * 20
46	1	Reducing ring
47	1	O-ring 3225

Fig. 11

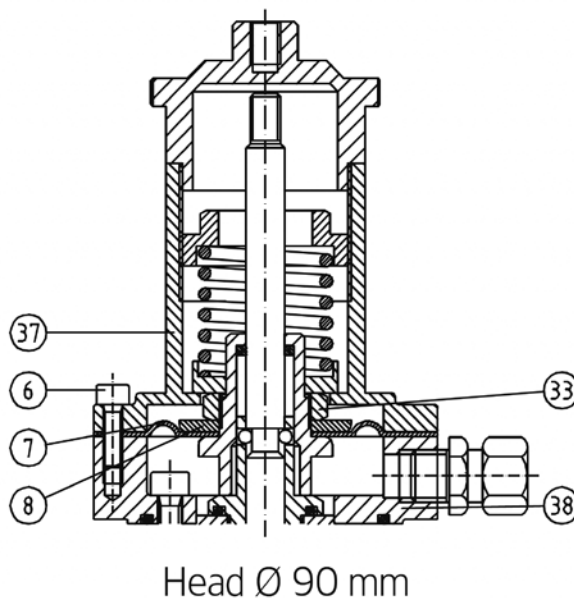
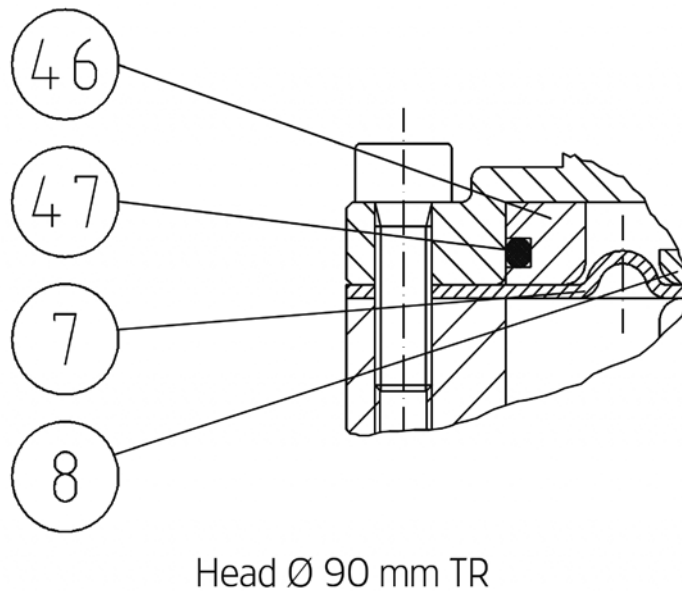

Fig. 12



Maintenance Tools

Type	Tool	DN 25	DN 40 / DN 50	DN 80
A	3			
	4	6	6	6
	5	9	9	9
	6			
	8			
B	13			
	17			
	19			
	30	3	3	3
C	10			
	13	10		
	17		10	
	19	44	44	44
	21			
	22			10
	24			
	30			
	32			
	35			
	40			

Fig. 14

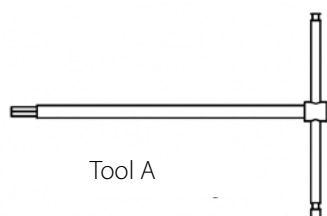

Tool A

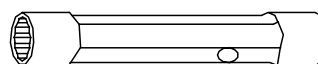

Tool B
UNI 6746 - 70



Chiave C
UNI 6733 - 70

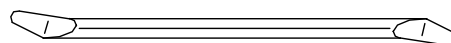

Tool for extraction O-Ring

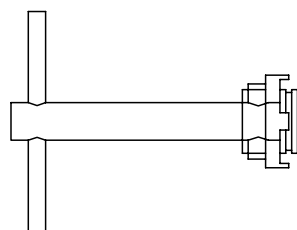

Disassembling tool for regulator and slam-shut valve seat
(cod. 20230100 to numb. 39923000 for DN 25)
to numb. 39925000 for DN 40)
to numb. 39926000 for DN 50)
to numb. 39927000 for DN 80)
to numb. 39929000 for DN 100)

Pressure loss calculation

Pressure loss of the shut-off valve Series 8500 is a function of pressure, temperature and gas density:

$$\Delta P = (Q / C_g)^2 \times 1 / P_e$$

where:

ΔP : pressure loss (bar)

P_e : absolute working pressure (bar)

Q : flow rate referred to normal conditions (nm³h)

C_g : flow coefficient (see table below), natural gas with relative density $d=0,6$ and absolute temperature 273K.

If density and temperature are different from normal conditions ($d = 0,6$ and $T_e = 273$ K), multiply the result with correction factor K:

$$K = (T_e + 273) / (0,6 \times 273) \sqrt{d/0,6D}$$

-where:

d : relative density of the relevant gas

T_e : gas temperature at the inlet of SSV in °C

Flow coefficient

DN	25	40	50	80
C_g	620	1140	1900	4700

Dresser Utility Solutions GmbH

Hardeckstr. 2

76185 Karlsruhe

T: +49 (0)721 / 5981 - 100

info.karlsruhe@dresserutility.com



www.dresserutility.com

© 2023 Dresser Utility Solutions GmbH – All rights reserved. Dresser Utility Solutions reserves the right to make changes in specifications and features shown herein, or discontinue the product described at any time without notice or obligation. Contact your Dresser Utility Solutions representative for the most current information. The Dresser Logo and all Trademarks containing the term "Dresser" are the property of Dresser, LLC, a subsidiary of Baker Hughes. Actaris™ is a trademark owned by Itron, Inc. and used under license.