

DRESSER Product Submittal

Style 38 Couplings for Cast/Ductile Iron Pipe

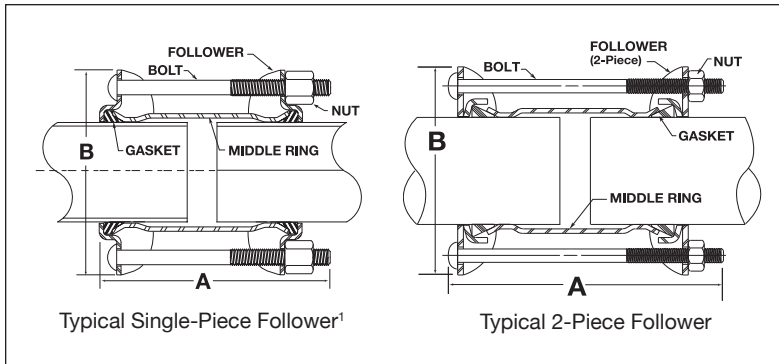

Style 38 Materials of Construction

Followers:	AISI C1012 or ASME SA36 (Ductile Iron or Malleable Iron for 1/2" thru 1-1/2")
Middle Ring:	ASTM A513, ASTM A635 or ASME SA675 GR60
Bolts:	AWWA C 111/ANSI A21.11
Gaskets:	Grade 27 BUNA-S as Standard
Coating:	Fusion-Bonded Epoxy; Optional RED-D Shopcoat

Style 38 Coupling Specifications for CIP/DIP Pipe Sizes 2" thru 24"

NOTE: Chart lists basic envelope dimensions as guidelines for standard Style 38 couplings. Consult factory for custom sizes.

Pipe Nominal Size (in)	Outside Pipe Diameter (OD)	Middle Ring Thickness & Length (in)	Bolts No./Diam. x Length (in)	OVERALL DIMENSIONS		Working Pressure Lbs. per Sq.In.	Approx. Shipping Weight (lbs.)
				Length (A)	Diameter (B)		
2	2.50	.180 x 5	3-5/8 x 8-1/4	8-5/8	6-1/2	1500	10
3	3.80	.188 x 5	4-5/8 x 8-1/4	8-5/8	8	1326	14
4	4.80	.299 x 5	4-5/8 x 8-1/4	8-5/8	9	1100	15
6	6.90	1/4 x 5	5-5/8 x 8-1/4	8-5/8	11	992	21
8	9.05	1/4 x 5	6-5/8 x 8-1/4	8-5/8	13-1/16	772	31
10	11.10	3/8 x 7	7-5/8 x 10-3/4	16	16	936	47
12	13.20	3/8 x 7	8-5/8 x 10-3/4	11-1/8	18-1/16	794	54
14	15.300	3/8 x 7	10-5/8 x 10-3/4	11-1/8	19-5/16	575	74
16	17.400	3/8 x 7	10-5/8 x 10-3/4	11-1/8	20-5/8	509	88
16	17.800	3/8 x 7	10-5/8 x 10-3/4	11-1/8	22-1/16	498	111
18	19.500	3/8 x 7	12-5/8 x 10-3/4	11-1/8	23-1/2	450	105
18	19.920	3/8 x 7	12-5/8 x 10-3/4	11-1/8	24-15/16	448	124
20	21.600	3/8 x 7	12-5/8 x 10-3/4	11-1/8	25-5/8	411	114
20	22.060	3/8 x 7	14-5/8 x 10-3/4	11-1/8	27-1/16	406	141
24	25.800	3/8 x 7	15-5/8 x 10-3/4	11-1/8	29-3/16	349	134
24	26.320	3/8 x 7	15-5/8 x 10-3/4	11-1/8	31-5/16	343	163

¹Single-Piece follower design used for couplings 3" thru 12"

CONSULT FACTORY FOR ALTERNATIVE GASKETS AND PART NUMBERS

Dresser Pipeline Solutions
41 Fisher Avenue
Bradford, PA 16701
P: 814.362.9300
F: 814.362.9344

Dresser Utility Solutions reserves the right to make changes in specifications and features shown herein, or discontinue any products described at any time without notice or obligation. Contact your Dresser Pipeline Solutions representative for the most current information.



© 2021 Natural Gas Solutions North America, LLC.
The Dresser Logo and all Trademarks containing the term "Dresser" are the property of Dresser, LLC, a subsidiary of Baker Hughes

SUBMITTAL.38.138.40.CIP.2021

DRESSER Product Submittal

Style 40 and Style 138 Couplings for Cast/Ductile Iron Pipe

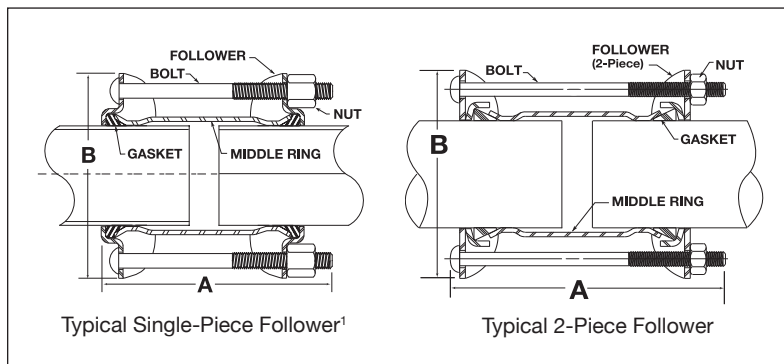

Materials of Construction	
Followers:	AISI C1012 or ASME SA36 (Ductile Iron or Malleable Iron for 1/2" thru 1-1/2")
Middle Ring:	ASTM A513, ASTM A635 or ASME SA675 GR60
Bolts:	AWWA C 111/ANSI A21.11
Gaskets:	Grade 27 BUNA-S as Standard
Coating:	Fusion-Bonded Epoxy; Optional RED-D Shopcoat

Style 40 Long-Body Coupling Specifications for CIP/DIP Pipe Sizes 2" thru 20"

NOTE: Chart lists basic envelope dimensions as guidelines for standard Style 38 couplings. Consult factory for custom sizes.

Pipe Nominal Size (IN)	Outside Pipe Diameter (OD)	Middle Ring Thickness & Length (IN)	Bolts No./Diam. x Length (IN)	OVERALL DIMENSIONS		Working Pressure Lbs. per Sq.In.	Approx. Shipping Weight (lbs.)
				Length (A)	Diameter (B)		
2	2.50	.188 x 12	3-5/8 x 15	15.5	6-1/2	1302	17
3	3.74 - 4.02	.188 x 12	4-5/8 x 15	15.5	7-3/4	939	24
4	4.74 - 5.06	.299 x 12	4-5/8 x 15	15.5	9	250	29
6	6.84 - 7.16	1/4 x 16	6-5/8 x 19-1/2	20	11	250	63
8	8.99 - 9.36	1/4 x 16	6-5/8 x 19-1/2	20	13-1/16	250	80
10	11.04 - 11.46	3/8 x 16	8-5/8 x 19-1/2	20	15-13/16	250	112
12	13.14 - 13.56	3/8 x 16	8-5/8 x 19-1/2	20	18-1/16	250	135
14	15.300	3/8 x 16	10-5/8 x 19-1/2	20	19-5/16	675	155
16	17.400	3/8 x 16	10-5/8 x 19-1/2	20	20-5/8	587	164
18	19.500	3/8 x 16	12-5/8 x 19-1/2	20	23-1/2	539	203
20	21.600	3/8 x 16	12-5/8 x 19-1/2	20	25-5/8	490	226

Style 138 Coupling Specifications for CIP/DIP Pipe Sizes 3" thru 12"

3	3.74 - 4.02	.188 x 5	4-5/8 x 8-1/4	9	7-3/4	250	15
4	4.74 - 5.06	.299 x 5	4-5/8 x 8-1/4	9	8/3/16	250	25
4	4.74 - 5.06	.299 x 7	4-5/8 x 10-3/4	11-1/8	8/3/16	250	28
6	6.84 - 7.16	1/4 x 5	6-5/8 x 8-1/4	9	11-3/16	250	26
6	6.84 - 7.16	1/4 x 7	6-5/8 x 10-3/4	11-1/8	11-3/16	250	33
8	8.99 - 9.36	1/4 x 5	6-5/8 x 8-1/4	9	13-5/16	250	40
8	8.99 - 9.36	1/4 x 7	6-5/8 x 10-3/4	11-1/8	13-5/16	250	43
10	11.04 - 11.46	3/8 x 7	8-5/8 x 10-3/4	11-1/8	15-3/4	250	55
12	13.14 - 13.56	3/8 x 7	8-5/8 x 10-3/4	11-1/8	17-3/4	250	65

CONSULT FACTORY FOR ALTERNATIVE GASKETS AND PART NUMBERS

Dresser Pipeline Solutions
 41 Fisher Avenue
 Bradford, PA 16701
 P: 814.362.9300
 F: 814.362.9344

Dresser Utility Solutions reserves the right to make changes in specifications and features shown herein, or discontinue any products described at any time without notice or obligation. Contact your Dresser Pipeline Solutions representative for the most current information.



© 2021 Natural Gas Solutions North America, LLC.
 The Dresser Logo and all Trademarks containing the term "Dresser" are the property of Dresser, LLC, a subsidiary of Baker Hughes

SUBMITTAL.38.138.40.CIP.2021