

INSTALLATION INSTRUCTION 0001-0735-999

Dresser ABS Coupling Thermal Insulation Shroud Kit

NOTE: Insulation Shroud Kits MUST be installed on all Fire Resistant Type ABS or Marine Couplings

1. Following the installation of the coupling, wrap insulation around outside diameter of coupling overlapping ends. Place insulation evenly side to side to assure ends meet the host pipe.
2. When two pieces of insulation are required, overlap joints uniformly.
3. Insulation may be held in place with adhesive tape while shroud is positioned.
4. Match mating shroud halves over insulation.
5. Insert hex head cap screws and tighten uniformly.

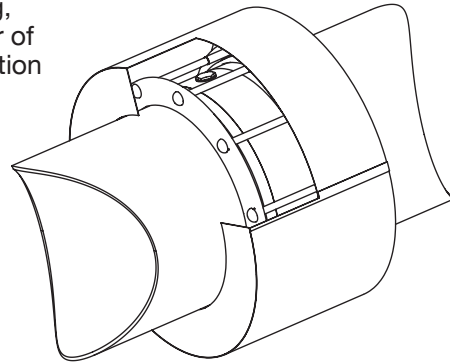

Dresser™ Pipeline Solutions

41 Fisher Avenue
Bradford, PA 16701
P: 814.362.9200
F: 814.362.9344

www.dresserngs.com

© 2018 Natural Gas Solutions North America, LLC. The Dresser Logo and all Trademarks containing the term "Dresser" are the property of Dresser, LLC, a subsidiary of Baker Hughes, a GE Company.

Part No. 0001-0735-999
12.2018